



City of Newburgh
Council Work Session
Sesion de trabajo del Concejal
May 7, 2026
6:00 PM

Council Meeting Presentations / Presentaciones de la Reunion General

1. Recognition of NFA Mock Trial Semi-Finalists

Reconocimiento de los semifinalistas del juicio simulado de la NFA

2. Public Hearing - Local Law establishing a Charter Review Commission

There will be a public hearing on Monday, May 11, 2026, to receive comments from the public concerning a Local Law of the City Council of the City of Newburgh establishing a Charter Review Commission

Se llevará a cabo una audiencia pública el lunes 11 de mayo de 2026 para recibir comentarios del público sobre una ley local del Consejo de la Ciudad de Newburgh para establecer una Comisión de Revisión de la Carta Orgánica

Department of Public Works / Departamento de Obras Publicas

3. Johnson Controls Fire Protection LP proposal - Broadway Courthouse

Resolution authorizing an agreement between the City of Newburgh and Johnson Controls Fire Protection LP for fire alarm repair services at the Broadway Courthouse in the amount of \$5,158.16

Resolución que autoriza un acuerdo entre la Ciudad de Newburgh y Johnson Controls Fire Protection LP para servicios de reparación del sistema de alarma contra incendios en el Tribunal de Broadway, por un monto de \$5,158.16

Engineering / Ingeniería

4. Change Order No. 2 with Barone Construction Group, Inc.

Resolution authorizing Change Order No. 2G to the construction contract with Barone Construction Group, Inc. for the Wastewater Treatment Plant Administration Building Rehabilitation Project

Resolución que autoriza la Orden de Cambio Núm. 2 al contrato de construcción con Barone Construction Group, Inc. para el proyecto de rehabilitación del edificio administrativo de la planta de tratamiento de aguas residuales

5. Change Order No. 1 with E-J Electric Installation Co.

Resolution authorizing Change Order No. 1 to the electrical contract with E-J Electric Installation Co. for the Wastewater Treatment Plant Administration Building Rehabilitation Project

Resolución que autoriza la Orden de Cambio Núm. 1 al contrato eléctrico con E-J Electric Installation Co. para el proyecto de rehabilitación del edificio administrativo de la planta de tratamiento de aguas residuales

6. Change Order No. 1 with DJ Heating & Air Conditioning, Inc.

Resolution authorizing Change Order No. 1 to the HVAC contract with DJ Heating & Air Conditioning, Inc. for the Wastewater Treatment Plant Administration Building Rehabilitation Project

Resolución que autoriza la Orden de Cambio Núm. 1 al contrato de HVAC con DJ Heating & Air Conditioning, Inc. para el proyecto de rehabilitación del edificio administrativo de la planta de tratamiento de aguas residuales

7. Change Order No. 1 with Verde Construction

Resolution authorizing Change Order No. 1 to the construction contract with Verde Electric Maintenance Corporation in the Broadway Pedestrian and Traffic Signals Improvements Project (PIN #8005.26 and PIN#8758.75)

Resolución que autoriza la Orden de Cambio Núm. 1 al contrato de construcción con Verde Electric Maintenance Corporation en el Proyecto del Mejoramiento de Señales Peatonales y de Tráfico de Broadway (PIN Núm. 8005.26 y PIN Núm. 8758.75)

8. PIN No. 8758.75 Supplemental Agreement No. 1 with NYSDOT

Resolution authorizing the City Manager to execute Master Federal-Aid Local Project Supplemental Agreement No. 1 with the New York State Department of Transportation authorizing the implementation, and funding in the first instance 100% of the Federal-Aid and State "Marchiselli" Program-Aid eligible costs, of a Transportation Federal-Aid Project, and appropriating funds therefore in the Traffic Signal Upgrades Project (PIN 8758.75)

Resolución que autoriza al Gerente de la Ciudad a ejecutar el Acuerdo Suplementario Maestro Núm. 1 de Proyecto Local con Asistencia Federal con el Departamento de Transporte del Estado de Nueva York, que autoriza la implementación y el financiamiento inicial del 100% de

los costos elegibles bajo la ayuda federal y el programa estatal "Marchiselli", correspondientes a un proyecto de transporte con asistencia federal, y que asigna los fondos para dicho fin en el Proyecto de Modernización de Señales de Tráfico (PIN 8758.75)

9. PIN No. 8005.26 Supplemental Agreement No. 1 with NYSDOT

Resolution authorizing the City Manager to execute Master Federal-Aid Local Project Supplemental Agreement No. 1 with the New York State Department of Transportation authorizing the implementation, and funding in the first instance 100% of the Federal-Aid and State "Marchiselli" Program-Aid eligible costs, of a Transportation Federal-Aid Project, and appropriating funds therefore in the Traffic Signal Upgrades Project (PIN 8005.26)

Resolución que autoriza al Gerente de la Ciudad a ejecutar el Acuerdo Suplementario Maestro Núm. 1 de Proyecto Local con Asistencia Federal con el Departamento de Transporte del Estado de Nueva York, que autoriza la implementación y el financiamiento inicial del 100% de los costos elegibles bajo la asistencia federal y el programa estatal "Marchiselli", correspondientes a un proyecto de transporte con asistencia federal, y que asigna los fondos para dicho fin en el Proyecto de Modernización de Señales de Tráfico (PIN 8005.26)

Finance / Finanza

10. Personnel book amendment to add the position of Temporary Part-Time Purchasing Agent

Resolution amending the 2026 Personnel Analysis Book to add one Temporary Part-Time Purchasing Agent in the Finance Department

Resolución que enmienda el Libro de Análisis de Personal 2026 para agregar un puesto de Agente de Compras temporal de medio tiempo en el Departamento de Finanzas

11. Update from Comptroller on Orange County Sales Tax Revenue Distribution Correction

Actualización del Contralor sobre la corrección en la distribución de ingresos por impuestos sobre ventas del Condado de Orange

Information Technology Department / Departamento de Tecnología e Información

12. NYS EFC SECURE Grant

Resolution authorizing the City Manager to apply for and accept if awarded a New York State Environmental Facilities Corporation

Strengthening Essential Cybersecurity for Utilities and Resiliency Enhancement (SECURE) Assessment Program Grant in the amount of \$50,000.00 with no City match

Resolución que autoriza al Gerente de la Ciudad a solicitar y, en caso de ser otorgada, aceptar una subvención del Programa de Evaluación SECURE (Fortalecimiento de la Ciberseguridad Esencial para Servicios Públicos y Mejora de la Resiliencia) de la Corporación de Instalaciones Ambientales del Estado de Nueva York, por un monto de \$50,000.00, sin aportación municipal

Planning and Economic Development / Planificación y Desarrollo Económico

13. Resolution No. 80-2026 - Amendment to Site Development Agreement with the Kearney Realty & Development Group, Inc.

Resolution authorizing the City Manager to execute a second amendment to a site development agreement with The Kearney Realty & Development Group, Inc. for the transfer and redevelopment of properties located at 137 Smith Street (Section 12, Block 4, Lot 4.1), 140 Montgomery Street (Section 12, Block 4, Lot 10) and 146 Montgomery Street (Section 12, Block 4, Lot 2.1)

Resolución que autoriza al Gerente de la Ciudad a ejecutar una segunda enmienda al acuerdo de desarrollo del sitio con The Kearney Realty & Development Group Inc. para la transferencia y remodelación de las propiedades ubicadas en 137 Smith Street (Sección 12, Bloque 4, Lote 4.1), 140 Montgomery Street (Sección 12, Bloque 4, Lote 10) y 146 Montgomery Street (Sección 12, Bloque 4, Lote 2.1)

14. Resolution No 81-2026 - PILOT Agreement with the Kearney Realty & Development Group, Inc.

Resolution authorizing the City Manager to execute an agreement for the payment in lieu of taxes between the City of Newburgh, the Green Housing Development Fund Company, Inc. and Newburgh Green Apartments Limited Partnership

Resolución que autoriza al Gerente de la Ciudad a ejecutar un acuerdo de pago en lugar de impuestos entre la Ciudad de Newburgh, The Green Housing Development Fund Company, Inc., y Newburgh Green Apartments Limited Partnership

Grants/Contracts/Agreements / Becas /Contratos/Convenios

15. License Agreement - Newburgh Sanctuary, Inc. - Blueblocks Floating Gardens at Crystal Lake

Resolution authorizing the City Manager to execute a license agreement

with Newburgh Sanctuary, Inc. to allow access to City-owned property known as Crystal Lake (Section 41, Block 2, Lot 11.2) for access related to the Blueblocks Floating Gardens Project

Resolución que autoriza al Gerente de la Ciudad a ejecutar un acuerdo de licencia con Newburgh Sanctuary, Inc. para permitir el acceso a la propiedad de la Ciudad conocida como Crystal Lake (Sección 41, Bloque 2, Lote 11.2) en relación con el Proyecto de Jardines Flotantes Blueblocks

Resolutions of Support / Resoluciones de Apoyo

16. The Hudson Highlands Conservation Act

Resolution of the City Council of the City of Newburgh affirming its willingness and intent to join the Federal Highlands Conservation Act Region

Resolución del Consejo de la Ciudad de Newburgh que afirma su disposición e intención de unirse a la región de la Ley Federal de Conservación de Highlands

17. Street Naming Request - Dr. Ralph E. Harris

Resolution naming the intersection of First Street and Montgomery Street in honor of Dr. Ralph Harris

Resolución que designa la intersección de First Street y Montgomery Street en honor al Dr. Ralph Harris

18. Street Naming Request - Robert W. Moody

Resolution naming the intersection of Montgomery Street and South Street in honor of Robert W. Moody

Resolución que designa la intersección de Montgomery Street y South Street en honor a Robert W. Moody

19. Key to the City Request - Harold Shirley

Resolution bestowing a Key to the City of Newburgh in honor of Harold Shirley

Resolución que otorga la Llave de la Ciudad de Newburgh en honor a Harold Shirley

Boards and Commissions / Juntas y Comisiones

20. Appointments - Newburgh Arts and Cultural Commission

Nombramientos – Comisión de Artes y Cultura de Newburgh

Discussion Items / Temas de Discusión

21. Green Light Legislation

Legislación Green Light

22. Land-Use Boards Audio & Recording

Audio y grabación de las juntas de uso de suelo

23. New City Parks Proposal

Propuesta de nuevos parques de la ciudad

Executive Session / Sesión Ejecutiva

24. Proposed, pending or current litigation

Litigio propuesto, pendiente o actual

25. The medical, financial, credit or employment history of a particular person or corporation, or matters leading to the appointment, employment, promotion, demotion, discipline, suspension, dismissal or removal of a particular person or corporation

El historial médico, financiero, crediticio o laboral de una persona o corporación en particular, o asuntos que conduzcan al nombramiento, empleo, promoción, degradación, disciplina, suspensión, despido o remoción de una persona o corporación en particular

RESOLUTION NO.: 92 - 2026

OF

APRIL 27, 2026

RESOLUTION SCHEDULING A PUBLIC HEARING FOR MAY 11, 2026
TO HEAR PUBLIC COMMENT CONCERNING A
LOCAL LAW OF THE CITY COUNCIL OF THE CITY OF NEWBURGH
ESTABLISHING A CHARTER REVIEW COMMISSION

NOW, THEREFORE, BE IT RESOLVED, by the Council of the City of Newburgh, New York, that there is hereby scheduled a public hearing to receive comments concerning "A Local Law of the City Council of the City of Newburgh establishing a Charter Review Commission"; and that such public hearing be and hereby is duly set for the next meeting of the Council to be held at 7:00 p.m. on the 11th day of May, 2026 in the Council Chambers, 83 Broadway, City Hall, 3rd Floor, Newburgh, New York.

I, Katrina Cotten, City Clerk of the City of Newburgh hereby certify that I have compared the foregoing with the original resolution adopted by the Council of the City of Newburgh at a regular meeting held 4/27/26 and that it is a true and correct copy of such original.

Witness my hand and seal of the City of Newburgh this 28th day of April, 2026

Katrina Cotten
City Clerk

LOCAL LAW NO.: _____ - 2026

OF

_____, 2026

**A LOCAL LAW OF THE CITY COUNCIL OF THE CITY OF NEWBURGH
ESTABLISHING A CHARTER REVIEW COMMISSION**

BE IT ENACTED, by the City Council of the City of Newburgh as follows:

SECTION 1 - TITLE

This Local Law shall be referred to as “A Local Law of the City Council of the City of Newburgh Establishing a Charter Review Commission”.

SECTION 2 - CHARTER REVIEW COMMISSION ESTABLISHED

§ 1. Establishment.

The City Council of the City of Newburgh hereby establishes a Charter Review Commission to draft a new or revised City Charter for the City of Newburgh.

§ 2. Membership; selection; qualifications; term of office.

- A. The Commission shall be comprised of 9 members, designated and appointed as follows:
 - 1. The Mayor and each Council Member shall appoint one (1) Commission Member for a total of seven (7) Commission Members.
 - 2. The City Council, by resolution, shall appoint two (2) Commission Members.
 - 3. The Mayor and each Council Member shall appoint one Alternate Member for a total of seven (7) Alternate Commission Members.
- B. There must be one resident of each ward appointed as a Commission Member.
- C. Applications for appointment to the Commission will be solicited through the City of Newburgh Board and Commission Appointment Policy and Procedure. The advertisement for applications will be issued within 14 days of the effective date of this local law. The period for submitting applications will be open for 30 days.
- D. All appointments shall be made at the next Council meeting cycle after the last day for submission of applications as provided in the advertisement. Vacancies in the Commission Members appointed by the Mayor and Council Members shall be filled by the corresponding

Alternate Members appointed by the Mayor and Council Members. If no Alternate Member is eligible to fill a vacancy then the vacancy shall be filled by in the same manner as the original appointment. The Alternate Members shall serve only in the event that a permanent vacancy occurs.

- E. The appointment of Commission members is intended to be nonpartisan.
- F. Residency within the City of Newburgh is required to be eligible for appointment to the Commission.
- G. No person shall be disqualified to serve as a member, employee or consultant of the Commission by reason of holding any other public office or employment, nor shall the person forfeit any such office or employment by reason of appointment to the Commission notwithstanding the provisions of any general, special or local law, ordinance or City charter.
- H. The terms of office of the Commission members expire on the day of the election at which the proposed new or revised charter prepared by the Commission is submitted to the qualified electors of the City of Newburgh or on the day of the second general election following the date of the effective date of this local law if no such questions have been submitted by that time.

§ 3. Powers and duties.

- A. The Commission shall have all the powers and duties set forth in Section 36 of the New York State Municipal Home Rule Law.
- B. The Commission shall review the entire charter of the City and prepare a draft of a proposed new or revised charter of the City. The Commission may decide to make no changes to the charter. If the Commission decides to make no changes, it shall prepare and provide a report to the public explaining its determination. The Commission may decide to leave a part of the existing charter unchanged, and it may propose in one or more amendments, a revision of the remaining part. If the Commission proposes one or more amendments, it shall prepare and provide to the public a report, accompanying its proposals, in which it explains its decision to leave such part unchanged and the rationale for the proposed amendments.
- C. Such new charter or amendments shall be completed and filed in the office of the City Clerk no later than the second general election after the Commission is created and organized.
- D. The Commission shall provide for the publication or other publicity of the proposed charter or amendments as it may deem proper, and for the submission thereof to the electors of the City at a general or special election held not earlier than 60 days after the filing thereof in the office of the City Clerk and not later than the next general election which does not occur within the said 60 days, provided, however, that if such general election occurs within 90 days after said filing, the proposed charter or amendments shall be submitted at such general

election. At such election, if a proposed new charter or significantly revised charter is submitted as a single proposal, there shall be submitted to the qualified electors of the City the question: "Shall the revised City Charter proposed by the City Charter Commission be adopted?" The Commission may submit its proposed or revised charter in 2 or more parts and arranged so that corresponding parts of the existing charter shall remain in effect if one or more of such parts are not adopted and also may submit separate amendments or alternative provisions to supersede designated portions of a proposed charter or amendment if adopted. In such case the Commission shall prescribe the form of the questions to be submitted, which shall be such as clearly to indicate the effect of their approval.

- E. No provision for the election of any elective officers by any system of proportional representation shall become effective under the provisions of this section unless a definite question with respect to the adoption of such system for the election of such officers shall have been submitted as a separate question and separately approved at the same election by the affirmative vote of a majority of the qualified electors voting thereon.
- F. If any question submitted by the Commission receives the affirmative vote of a majority of the qualified electors of the city voting thereon, the proposal submitted thereby shall take effect as specified therein and the new charter or the amendment or amendments to the existing charter as so proposed shall become operative as prescribed therein; except that if there be a conflict between the provisions of two or more proposals approved by the electors at the same election, the proposal receiving the largest number of affirmative votes shall prevail to the extent of such conflict.
- G. At any election at which any question or questions shall be submitted to the qualified electors of the City by the Commission pursuant to this section or within sixty days thereafter, no other question or questions shall be submitted to or voted upon by such electors pursuant to any local law, ordinance, resolution or petition if such commission was created pursuant to subsection 4 of the New York State Municipal Home Rule Law, and no such other question or questions shall be submitted except by another charter commission if such commission was created otherwise, if such other question or questions involve or relate directly or indirectly to the adoption of a new city charter, the amendment of a city charter, charter revision, the establishment of a commission to draft a new or revised city charter, or the functions, powers or duties of any elective officer of the city, except as provided in paragraph 6 of subsection 5(g) of the New York State Municipal Home Rule Law.
- H. While the Commission is in existence under the provisions of this local law, the local legislative body shall not submit to the electors any of the questions specified in subsection 5(e) of the New York State Municipal Home Rule Law except at a general election.
- I. If a proposed local law submitted pursuant to section 37 of the New York State Municipal Home Rule Law would under the provisions of such section be submitted at a general election at which a question or questions submitted by a charter commission are to be voted on, such local law shall not be submitted at such election but shall be submitted at the general

election in the year following regardless of other questions which may be voted on at the latter election and notwithstanding any inconsistent provision of this title.

§ 4. Procedures; appropriations; rules and regulations.

- A. The Commission may designate its chairperson and vice-chairperson from among its members. The chairperson shall preside over all meetings and hearings. In the absence of the chairperson, the vice-chairperson shall act in their stead. In the absence of both the chairperson and vice-chairperson, a majority of members present shall select a chairperson pro tempore to preside over the meeting.
- B. The Commission shall adopt rules and procedures governing its meetings and keep accurate records of its meetings and activities.
- C. Commission meetings shall be held in accordance with applicable provisions of New York State Law.
- D. The Commission shall conduct at least one public hearing. All public hearings shall be held at such time and place within the City of Newburgh as the Commission shall deem necessary.
- E. The Commission shall have the power to conduct private hearings, take testimony, subpoena witnesses and require the production of books, papers and records.
- F. Members of the Commission shall receive no compensation for the services but shall be reimbursed for the actual and necessary expenses incurred by them in the performance of their duties.
- G. The Commission may appoint and remove employees and consultants and fix their compensation and may accept any services, facilities or funds and use or expend the same for its purposes. The Commission may request that the City Manager direct any board, body, officer, or employee of the City to cooperate with, assist, advise, provide facilities, materials or date and render services to the Commission.
- H. The Commission may request that the appropriate City officials make appropriations for its expenses incurred in the course of its operations. In the event that the appropriating body or officials do not take affirmative action to appropriate funds for such expenses within 45 days of the Commission's request, the Mayor of the City shall have the power to authorize, by certificate filed with the fiscal officer(s) of the City, the Commission to incur expenses within the amounts requested, which shall be paid by the appropriate officials of the City.

SECTION 3 - SEVERABILITY

The provisions of this Local Law are separable and if any provision, clause, sentence, section, subsection, word or part thereof is held to be illegal, invalid, or unconstitutional, or inapplicable to any person or circumstance, such illegality, invalidity, or unconstitutionality, or inapplicability shall not affect or impair any of the remaining provisions, clauses, sentences, subsections, words or parts of this Local Law or their application to other persons or circumstances. It is hereby declared to be the legislative intent that this Local Law would have been adopted if such illegal, invalid, or unconstitutional provision, clause, sentence, subsection, word or part had not been included therein, and if such person or circumstance to which the Local Law or part here of is held inapplicable had been specifically exempt therefrom.

SECTION 4 - VALIDITY

The invalidity of any provision of this Local Law shall not affect the validity of any other provision of this Local Law that can be given effect without such invalid provision.

SECTION 5 - EFFECTIVE DATE

This Local Law shall be effective after the filing in the Office of the New York State Secretary in accordance with the provisions of New York State Municipal Home Rule Law.

RESOLUTION NO.: _____ - 2026

OF

MAY 11, 2026

**A RESOLUTION AUTHORIZING AN AGREEMENT BETWEEN
THE CITY OF NEWBURGH AND JOHNSON CONTROLS FIRE PROTECTION LP
FOR FIRE ALARM REPAIR SERVICES AT THE BROADWAY COURTHOUSE
IN THE AMOUNT OF \$5,158.16**

WHEREAS, the City of Newburgh requires diagnostic services and repairs to the fire alarm system at the Broadway Courthouse; and

WHEREAS, the City of Newburgh has identified Johnson Controls Fire Protection LP as a company with the requisite skill and expertise to undertake evaluations and make necessary repairs to the fire alarm system at the Broadway Courthouse; and

WHEREAS, the cost of these services will be derived from A.1121.0448 and is partially reimbursable through a contract with the New York State Unified Court System; and

WHEREAS, this Council has determined that entering into an agreement with Johnson Controls Fire Protection LP is in the best interests of the City of Newburgh;

NOW, THEREFORE BE IT RESOLVED, by the Council of the City of Newburgh, New York that the City Manager be and he is hereby authorized to enter into an agreement with Johnson Controls Fire Protection LP to undertake evaluation and repairs to fire alarm system located at the Broadway Courthouse in the amount of \$5,158.16.



PROPOSAL AND SERVICE AGREEMENT

| | | |
|--|--|---|
| Date: 04-21-2026 SR#: Quote Ref: SOS Newburgh Courthouse Annunciator - CPQ-1177625 | Customer #:527490 Proposal #: CPQ-1177625 | Prepared By: Eric Johnson Employee Number: 510739 Phone #: Email: eric.johnson@jci.com |
| Purchaser Contact Information: Name: Chad Wade | | Phone: Email: cwade@cityofnewburgh-ny.gov |

Johnson Controls Fire Protection LP ("Company"), for and in consideration of the prices herein named, proposes to furnish the work, and or materials hereinafter described, subject to the terms and conditions of this Agreement.

| Ship To Information | Bill To Information |
|---|---|
| Newburgh City of New Courthouse , 300 Broadway , NEWBURGH, NY, 12550-5464 . | Newburgh City of Bureau Audit Control , 83 Broadway, NEWBURGH, NY, 12550-5617 . |

Scope of Work

Johnson Controls Fire Protection will provide labor and technical services to troubleshoot the existing fire alarm control panel and identify issues related to the corrupted program on the Notifier fire alarm system.

JCI will perform all necessary programming to correct and restore the system to proper operating condition.

In addition, JCI will remove and replace the damaged fire alarm annunciator located in the main floor lobby and replace one heat detector currently displaying a trouble condition; the replacement heat detector will be provided by the customer.

Upon completion of repairs, JCI will conduct required system testing to verify proper operation of the affected devices and fire alarm functions. A copy of the fire alarm control panel program will be provided to the customer upon completion for site records and safekeeping, and all work will be performed in accordance with applicable codes, standards, and manufacturer requirements.

NYS Pricing applied: Contract #PT68816

| QTY | MODEL NUMBER | DESCRIPTION |
|-----|--------------|---|
| 8 | HRDW OP RG | L&M Labor Regular |
| 1 | NF-F1P1-9660 | Notifier FDU-80 Annunciator 80 Char Dsply Security Keypad |



1 DPSUB SUBCONTRACTING LABOR

Total net selling price, \$5,158.16

Johnson Controls has **not** included an estimate for all state and local sales tax for this quote based on the understanding that a valid exemption and/or resale certificate is received by Johnson Controls from Purchaser. Otherwise, actual sales tax due will be calculated and billed. Any additional taxes, duties, tariffs or similar items imposed prior to shipment will be charged.

Relevant URLs

For ordering parts, please order from <https://fire.solutions.jci.com/spare-parts>

| | |
|---|--|
| Prevailing Wage Required? <u>Yes</u> Certified Payroll Required? <u>Yes</u> Customer/Site Tax Exempt? <u>Yes</u> | Working Hours: Based on normal business hours Mon-Fri 7:30AM-4:00PM unless otherwise noted. |
| Payment Terms: Net 30 | Total quote value: \$5,158.16 |

| | | |
|--------------------------------------|--|------------------------------|
| <input type="checkbox"/> Fixed Price | <input checked="" type="checkbox"/> Labor and Material | <input type="checkbox"/> NTE |
| "This Proposal is valid for 30 days" | | |

| | |
|---|--|
| Name: _____ Title: _____ PO#: _____ Signature: _____ | Johnson Controls Fire Protection LP 700 Corporate Park Blvd, Unit A-3 Newburgh, NY 12550 |
|---|--|

TERMS AND CONDITIONS

1. Term. The Initial Term of this Agreement shall commence on the date of this Agreement and continue as set forth herein. After the Initial Term, this Agreement shall automatically extend for successive terms equal to the same length as the Initial Term unless Customer or Company gives written notice to the other that it does not want to renew at least sixty (60) days prior to the end of the then-current term (each a ("Renewal Term"). The Initial Term and any Renewal Term may be referred to herein as the "Term."

2. Payment and Invoicing. Unless otherwise agreed by the parties in writing, fees for Services to be performed shall be paid annually in advance. Fees and other amounts due hereunder are due thirty (30) days from the date of invoice, which shall be paid by Customer via electronic delivery via EFT/ACH. Such payment is a condition precedent to Company's obligation to perform Services under the Agreement. Any invoice disputes must be identified in writing by Customer within 21 days of the invoice date. Payments of any disputed amounts are due and payable upon resolution.

Work performed on a time and material basis shall be at the then-prevailing Company rate for material, labor, and related items, in effect at the time supplied under this Agreement. Customer acknowledges and agrees that timely payments of the full amounts listed on invoices is an essential term of this Agreement and Customer's failure to make payment in full when due is a material breach of this Agreement. Customer further acknowledges that if there is any amount outstanding on an invoice, it is material to Company and will give Company, without prejudice to any other right or remedy, the right to, without notice: (i) suspend, discontinue or terminate performing any Services and/or withhold further deliveries of equipment and other materials, terminate or suspend any unpaid software licenses, and/or suspend Company's obligations under or terminate this Agreement; (ii) charge Customer interest on the amounts unpaid at a rate equal to the lesser of one and one half (1.5) percent per month or the maximum rate permitted under applicable law, until payment is made in full; and (iii) pay all of JCI's costs of collection, including (1) actual out of pocket expenses and (2) charge Customer a collection fee of twenty-five percent (25%) of the past due amount if collected through a collection agency or attorney and thirty-five percent (35%) if litigation is commenced to collect such past due amount. Company's election to continue providing future services does not, in any way diminish Company's right to terminate or suspend services or exercise any or all rights or remedies under this Agreement. Company shall not be liable for any damages, claims, expenses, or liabilities arising from or relating to suspension of Services for non-payment. In the event that there are exigent circumstances requiring services or the Company otherwise performs Services at the premises following suspension, those services shall be governed by the terms of this Agreement unless a separate contract is executed. If Customer disputes any late payment notice or Company's efforts to collect payment, Customer shall immediately notify Company in writing and explain the basis of the dispute. Customer agrees to pay all of Company's reasonable collection costs (including legal fees and expenses). In the event of Customer's default, the balance of any outstanding amounts will be immediately due and payable. Customer shall provide financial information requested by Company to verify Customer's ability to pay for goods or

services. If Customer fails to provide financial information or if Company, in its sole discretion determines that reasonable grounds exist to question Customer's ability or willingness to make payments when due (e.g., not making payments when due, late payments, or a reduction in Customer's credit score), Company may defer shipments, change payment terms, require cash in advance and/or require other security, without liability and without waiving any other remedies Company may have against Customer. Company shall provide Customer with advance written notice of changes to payment terms. Customer agrees to issue and send a purchase order to Company at least thirty (30) days prior to expiration of the Initial Term or any Renewal Term if necessary for payments to be processed, but failure to do so is not a pre-condition to Renewal Term payments being due to Company. No purchase order is required for any emergency work requested by Customer. Customer shall have no right to reject such invoices due to the lack of a purchase order.

3. Pricing. The pricing set forth in this Agreement is based on the number of devices and services to be performed as set forth in this Agreement. If the actual number of devices installed or services to be performed is greater than that set forth in this Agreement, the price will be increased accordingly. Company may increase prices upon notice to Customer to reflect increases in material and labor costs. Prices do not include taxes, fees, duties, tariffs, false alarm assessments, permits and levies or other charges imposed and/or enacted by a government, however designated or imposed (collectively, "Taxes"). All Taxes are the responsibility of Customer, unless Customer presents an exemption certificate acceptable to Company and the applicable taxing authorities. If Company is required to pay any such Taxes or other charges, Customer shall reimburse Company on demand. If any such exemption certificate is invalid, then Customer will immediately pay Company the amount of the Taxes, plus penalties and interest.

Prices may be adjusted by Company prior to shipment to take into account increases in the cost of raw materials, component parts, third party products or labor rates or taxes; Trade Restrictions (as defined below); government actions; or to cover any unforeseen or other extra cost elements. "Trade Restrictions" means any additional or new tariff/duty, quota, tariff-rate quota, or cost associated with the withdrawal of tariff/duty concessions pursuant to a trade agreement(s).

This Agreement is entered into with the understanding that the services to be provided by Company are not subject to any local, state, or federal prevailing wage statute. If it is later determined that local, state, or federal prevailing wage rates apply to the services to be provided by Company, Company reserves the right to issue a modification or change order to adjust the wage rates to the required prevailing wage rate. Customer agrees to pay for the applicable prevailing wage rates. Prices in any quotation or proposal from Company are subject to change upon notice sent to Customer at any time before the quotation or proposal has been accepted. If this Agreement is renewed, Company will provide Customer with notice of any adjustments in the contract price applicable to any Renewal Term. Unless Customer terminates the Agreement at least sixty (60) days prior to the start of such Renewal Term, the adjusted price shall be the price for the Renewal Term. If this Agreement extends beyond one year, Company may increase prices upon notice to Customer.

4. Code Compliance. Company does not undertake an obligation to inspect for compliance with laws or regulations unless specifically stated in this Agreement. Customer acknowledges that the Authority Having Jurisdiction (e.g. Fire Marshal) may establish additional requirements for compliance

with local codes. Any additional services or equipment required will be provided at an additional cost to Customer.

5. Limitation of Liability; Limitations of Remedy. Customer understands that Company offers several levels of protection services and that the level described has been chosen by Customer after considering and balancing various levels of protection afforded and their related costs. It is understood and agreed by Customer that Company is not an insurer and that insurance coverage shall be obtained by Customer and that amounts payable to Company here under are based upon the value of the services and the scope of liability set forth in this Agreement and are unrelated to the value of Customer's property and the property of others located on the premises. Customer agrees to look exclusively to Customer's insurer to recover for injuries or damage in the event of any loss or injury. Customer releases and waives all right of recovery against Company arising by way of subrogation. Company makes no guaranty or warranty, including any implied warranty of merchantability or fitness for a particular purpose that equipment or services supplied by Company will detect or avert occurrences or the consequences there from that the equipment or service was designed to detect or avert. It is impractical and extremely difficult to fix the actual damages, if any, which may proximately result from failure on the part of Company to perform any of its obligations under this Agreement. Accordingly, Customer agrees that Company shall be exempt from liability for any loss, damage or injury arising directly or indirectly from occurrences, or the consequences there from, which the equipment or service was designed to detect or avert. Should Company be found liable for any loss, damage or injury arising from a failure of the equipment or service in any respect, Company's liability shall be limited to an aggregate amount equal to the Agreement price (as increased by the price for any additional work) or, where the time and material payment term is selected, Customer's time and material payments to Company. Where this Agreement covers multiple sites, liability shall be limited to the amount of the payments allocable to the site where the incident occurred. Company's liability with respect to Monitoring Services is set forth in Section 18 of this Agreement. Such sum shall be complete and exclusive. IN NO EVENT SHALL COMPANY BE LIABLE, FOR ANY DAMAGE, LOSS, INJURY, OR ANY OTHER CLAIM ARISING FROM ANY SERVICING, ALTERATIONS, MODIFICATIONS, CHANGES, OR MOVEMENTS OF THE COVERED SYSTEM(S), AS HEREIN AFTER DEFINED, OR ANY OF ITS COMPONENT PARTS BY CUSTOMER OR ANY THIRD PARTY. To the maximum extent permitted by law, in no event shall Company and its affiliates and their respective personnel, suppliers and vendors be liable to Customer or any third party under any cause of action or theory of liability, even if advised of the possibility of such damages, for any (a) special, incidental, consequential, punitive or indirect damages of any kind; (b) loss of profits, revenues, data, customer opportunities, business, anticipated savings or goodwill; (c) business interruption; or (d) data loss or other losses arising from viruses, ransomware, cyber-attacks or failures or interruptions to network systems. The limitations of liability set forth in this Agreement shall inure to the benefit of all parents, subsidiaries and affiliates of Company, whether direct or indirect, Company's employees, agents, officers and directors.

6. Reciprocal Waiver of Claims (SAFETY Act). Certain of Company's systems and services have received Certification and/or Designation as Qualified Anti-Terrorism Technologies ("QATT") under the Support Antiterrorism by Fostering Effective Technologies Act of 2002, 6 U.S.C. §§441-444 (the "SAFETY

Act"). As required under 6 C.F.R. 25.5 (e), to the maximum extent permitted by law, Company and Customer hereby agree to waive their right to make any claims against the other for any losses, including business interruption losses, sustained by either party or the irrelative employees, resulting from an activity resulting from an "Act of Terrorism" as defined in 6 C.F.R. 25.2, when QATT have been deployed in defense against, response to, or recovery from such Act of Terrorism.

7. Indemnity. Customer agrees to indemnify, hold harmless and defend Company against any and all losses, damages, costs, including expert fees and costs, and expenses including reasonable defense costs, arising from any and all third party claims for personal injury, death, property damage or economic loss, arising in any way from any act or omission of Customer or Company relating in any way to this Agreement, including but not limited to the Services under this Agreement, whether such claims are based upon contract, warranty, tort (including but not limited to active or passive negligence), strict liability or otherwise. Company reserves the right to select counsel to represent it in any such action. Customer's responsibility with respect to indemnification and defense of Company with respect to Monitoring Services is set forth in Section 18 of this Agreement.

8. General Provisions. Customer has selected the service level desired after considering and balancing various levels of protection afforded and their related costs. All work to be performed by Company will be performed during normal working hours of normal working days (8:00 a.m. - 5:00 p.m., Monday through Friday, excluding Company holidays), as defined by Company, unless additional times are specifically described in this Agreement. All work performed unscheduled unless otherwise specified in this Agreement. Appointments scheduled for four-hour window. Additional charges may apply for special scheduling requests (e.g. working around equipment shutdowns, after hours work). Company will perform the services described in the Service Solution ("Services") for one or more system(s) or equipment as described in the Service Solution or the listed attachments ("Covered System(s)"). UNLESS OTHERWISE SPECIFIED IN THIS AGREEMENT, ANY INSPECTION (AND, IF SPECIFIED, TESTING) PROVIDED UNDER THIS AGREEMENT DOES NOT INCLUDE ANY MAINTENANCE, REPAIRS, ALTERATIONS, REPLACEMENT OF PARTS, OR ANY FIELD ADJUSTMENTS WHATSOEVER, NOR DOES IT INCLUDE THE CORRECTION OF ANY DEFICIENCIES IDENTIFIED BY COMPANY TO CUSTOMER. COMPANY SHALL NOT BE RESPONSIBLE FOR EQUIPMENT FAILURE OCCURRING WHILE COMPANY IS IN THE PROCESS OF FOLLOWING ITS INSPECTION TECHNIQUES, WHERE THE FAILURE RESULTS FROM THE AGE OR OBSOLESCENCE OF THE ITEM OR DUE TO NORMAL WEAR AND TEAR. THIS AGREEMENT DOES NOT COVER SYSTEMS, EQUIPMENT, COMPONENTS OR PARTS THAT ARE BELOW GRADE, BEHIND WALLS OR OTHER OBSTRUCTIONS OR EXTERIOR TO THE BUILDING, ELECTRICAL WIRING, AND PIPING.

9. Customer Responsibilities. Customer shall regularly test the System(s) in accordance with applicable law and manufacturers' and Company's recommendations. Customer shall promptly notify Company of any malfunction in the Covered System(s) which comes to Customer's attention. This Agreement assumes any existing system(s) are in operational and maintainable condition as of the Agreement date. If, upon inspection, Company determines that repairs are recommended, repair charges will be submitted for approval by

Customer's on-site representative prior to work. Should such repair work be declined, Company shall be relieved from any and all liability arising therefrom. Customer further agrees to:

- provide Company clear access to Covered System(s) to be serviced including, if applicable, lift trucks or other equipment needed to reach inaccessible equipment;
- supply suitable electrical service, heat, heat tracing adequate water supply, and required system schematics and/or drawings;
- notify all required persons, including but not limited to authorities having jurisdiction, employees, and monitoring services, of scheduled testing and/or repair of systems;
- provide a safe work environment;
- in the event of an emergency or Covered System(s) failure, take reasonable precautions to protect against personal injury, death, and/or property damage and continue such measures until the Covered System(s) are operational; and
- comply with all laws, codes, and regulations pertaining to the equipment and/or Services provided under this Agreement. Customer represents and warrants that it has the right to authorize the Services to be performed as set forth in this Agreement.

JCI may terminate the Services immediately upon notice to the Customer if JCI, in its sole discretion determines that the Customer's premises are unsafe to be accessed by JCI'S employees or subcontractors. JCI may terminate the Services upon notice to the Customer, if Customer does not follow JCI's recommendations for updates and upgrades to the equipment and systems.

Customer represents and warrants that it has the right to authorize the Services to be performed as set forth in this Agreement. Customer is solely responsible for the establishment, operation, maintenance, access, security and other aspects of its computer network ("Network") and shall supply Company secure Network access for providing its services. Products networked, connected to the internet, or otherwise connected to computers or other devices must be appropriately protected by Customer and/or end user against unauthorized access. Customer is responsible to take appropriate measures, including performing back-ups, to protect information, including without limit data, software, or files (collectively "Data") prior to receiving the service or products.

10. Repair Services. Where Customer expressly includes repair, replacement, and emergency response services in the Service Solution section of this Agreement, such Services apply only to the components or equipment of the Covered System(s). Customer agrees to promptly request repair services in the event the System becomes inoperable or otherwise requires repair. The Agreement price does not include repairs to the Covered System(s) recommended by Company as a result of an inspection, for which Company will submit independent pricing to Customer and as to which Company will not proceed until Customer authorizes such work and approves the pricing. Repair or replacement of non-maintainable parts of the Covered System(s) including, but not limited to, unit cabinets, insulating material, electrical wiring, structural supports, and all other non-moving parts, is not included under this Agreement.

11. System Equipment. The purchase of equipment or peripheral devices, (including but not limited to smoke detectors, passive infrared detectors, card readers, sprinkler system components, extinguishers and hoses) from Company shall be subject to the terms and conditions of this Agreement. If, in Company's sole judgment, any peripheral device or other system equipment, which is attached to the Covered System(s), whether provided by Company, Customer or a third party, interferes with the proper operation of the Covered System(s), Customer shall remove or replace such device or equipment promptly upon notice from Company. Failure of Customer to remove or replace the device shall constitute a

material breach of this Agreement. If Customer adds any third party device or equipment to the Covered System(s), Company shall not be responsible for any damage to or failure of the Covered System(s) caused in whole or in part by such device or equipment.

12. Reports. Where inspection and/or test services are selected, such inspection and/or test shall be completed on Company's then current report form, which shall be given to Customer, and, where applicable, Company may submit a copy thereof to the local authority having jurisdiction. The report and recommendations by Company are only advisory in nature and are intended to assist Customer in reducing the risk of loss to property by indicating obvious defects or impairments noted to the system and equipment inspected and/or tested. They are not intended to imply that no other defects or hazards exist or that all aspects of the Covered System(s), equipment, and components are under control at the time of inspection. Final responsibility for the condition and operation of the Covered System(s) and equipment and components lies with Customer.

13. Availability and Cost of Steel, Plastics & Other Commodities. Company shall not be responsible for failure to provide services, deliver products, or otherwise perform work required by this Agreement due to lack of available steel products or products made from plastics or other commodities. In the event Company is unable, after reasonable commercial efforts, to acquire and provide steel products, or products made from plastics or other commodities, if required to perform work required by this Agreement, Customer hereby agrees that Company may terminate the Agreement, or the relevant portion of the Agreement, upon notice to Customer and at no additional cost and without penalty. Customer agrees to pay Company in full for all work performed up to the time of any such termination.

14. Confined Space. If access to confined space by Company is required for the performance of Services, Services shall be scheduled and performed in accordance with Company's then-current hourly rate.

15. Hazardous Materials. Customer represents that, except to the extent that Company has been given written notice of the following hazards prior to the execution of this Agreement, to the best of Customer's knowledge there is no:

- Space in which work must be performed that, because of its construction, location, contents or work activity therein, accumulation of a hazardous gas, vapour, dust or fume or the creation of an oxygen-deficient atmosphere may occur,
- "permit confined space," as defined by OSHA for work Company performs in the United States;
- risk of infectious disease;
- need for air monitoring, respiratory protection, or other medical risk; or
- asbestos, asbestos-containing material, formaldehyde or other potentially toxic or otherwise hazardous material contained in or on the surface of the floors, walls, ceilings, insulation or other structural components of the area of any building where work is required to be performed under this Agreement.

All of the above are herein after referred to as "Hazardous Conditions." Company shall have the right to rely on the representations listed above. If Hazardous Conditions are encountered by Company during the course of Company's work, the discovery of such materials shall constitute an event beyond Company's control, and Company shall have no obligation to further perform in the area where the Hazardous Conditions exist until the area has been made safe by Customer as certified in writing by an independent testing agency, and

Customer shall pay disruption expenses and re-mobilization expenses as determined by Company. This Agreement does not provide for the cost of capture, containment or disposal of any hazardous waste materials, or hazardous materials, encountered in any of the Covered System(s) and/or during performance of the Services. Said materials shall at all times remain the responsibility and property of Customer. Company shall not be responsible for the testing, removal or disposal of such hazardous materials.

16. Covid-19 Vaccination. Company expressly disclaims any requirement, understanding or agreement, express or implied, included directly or incorporated by reference, in any Customer purchase order, solicitation, notice or otherwise, that any of Company's personnel be vaccinated against Covid-19 under any federal, state/provincial or local law, regulation or order applicable to government contracts or subcontracts, including, without limitation, Presidential Executive Order 14042 ("Ensuring Adequate COVID Safety Protocols for Federal Contractors") and Federal Acquisition Regulation (FAR) 52.223-99 ("Ensuring Adequate COVID Safety Protocols for Federal Contractors"). Any such requirement shall only apply to Company's personnel if and only to the extent contained in a written agreement physically signed by an authorized officer of Company.

17. Other Services.

A. Remote Service. If Customer selects Remote Service, Company shall provide support for the Customer's system by way of education, remote assistance and triage that does not require programming changes to the Customer's panel. In addition, Remote Service does not include service to address physical damage to the system or a device; troubleshoot wiring issues; programming changes and/or relocating, remounting, reconnecting, or adding a device to the system. Customer understands and agrees that, while Remote Service provides for communication regarding Customer's fire alarm system to Company via the Internet, Remote Service does not constitute monitoring of the system, and Customer understands that Remote Service does not provide for Company to contact the fire department or other authorities in the event of a fire alarm. Customer understands that if it wishes to receive monitoring of its fire alarm system and notification of the fire department or other authorities in the event of a fire alarm, it must select monitoring services as a separate Service under this Agreement. CUSTOMER FURTHER UNDERSTANDS AND AGREES THAT THE TERMS OF SECTION 18.F OF THIS AGREEMENT APPLY TO REMOTE SERVICE.

B. Connected Fire Sprinkler Services; Connected Fire Alarm Services. Connected Fire Sprinkler Services and Connected Fire Alarm Services each means a data-analytics and software platform that uses a cellular or network connection to gather equipment performance data about a Customer's Covered Equipment for Customer's sprinkler system or fire alarm system, as applicable, to assist JCI in advising Customer on such equipment's health, performance or potential malfunction. Connected Fire Sprinkler Services and Connected Fire Alarm Services are collectively, the Connected Equipment Services. If Customer has purchased Connected Fire Sprinkler Services and/or Connected Fire Alarm Services on any Covered Equipment, Customer agrees to allow Company to install diagnostic sensors and communication hardware ("Gateway Device") or Customer will supply a network connection suitable to enable communication with Customer's Covered Equipment in order for Company to deliver the connected services. For more information on whether your particular equipment includes Connected Fire Sprinkler

Services and/or Connected Fire Alarm Services, a subscription to such services and the cost, if any, of such subscription, please see your applicable order, quote, proposal or purchase documentation or talk to your JCI sales representative. For certain subscriptions, Customer will be able to access equipment information from a mobile or smart device using the service's mobile or web app. The Gateway Device will be used to access, store, and trend data for the purposes of providing Connected Fire Sprinkler Services. Company will not use Connected Fire Sprinkler Services or the Connected Fire Alarm Services to remotely operate or make changes to Customer's Equipment. If the connection is disconnected by Customer, and a technician needs to be dispatched to the Customer site, then the Customer will pay JCI at JCI's then-current standard applicable contract regular time and/or overtime rate for such services. Company makes no warranty or guarantee relating to the Connected Fire Sprinkler Services or Connected Fire Alarm Services. Customer acknowledges that, while Connected Fire Alarm Services or Connected Sprinkler Services generally improve equipment performance and services, these services do not prevent all potential malfunction, insure against all loss or guarantee a certain level of performance and that JCI shall not be responsible for any injury, loss, or damage caused by any act or omission of JCI related to or arising from the proactive health notifications of the equipment under Connected Equipment Services. Customer understands that if it wishes to receive monitoring of its fire alarm system or sprinkler system and notification of the fire department or other authorities in the event of an alarm, it must select monitoring services as a separate Service under this Agreement. CUSTOMER FURTHER UNDERSTANDS AND AGREES SECTION 19 (SOFTWARE AND DIGITAL SERVICES) APPLY TO CONNECTED FIRE ALARM SERVICES AND CONNECTED SPRINKLER SERVICES. In the event of a conflict between these terms and the Software Terms, the Software Terms will control.

C. Dashboards and Mobility Applications for Connected Fire Sprinkler Services and Connected Fire Alarm Services. If Customer has purchased Connected Fire Sprinkler Services and/or Connected Fire Alarm Services, Customer may utilize Company's Dashboard(s) and Mobility Application(s), as applicable, during the term of the Agreement, pursuant to the then applicable Terms of Use Agreement. Terms for the Dashboard are located at <https://www.johnsoncontrols.com/buildings/legal/digital/general>.

18. Monitoring Services. If Customer has selected Monitoring Services, the following shall apply to such Services:

A. Alarm Monitoring Service. Customer agrees and acknowledges that Company's sole and only obligation under this Agreement shall be to provide alarm monitoring, notification, and/or Runner Services as set forth in this Agreement and to endeavor to notify the party(ies) identified by Customer on the Contact/Call List ("Contacts") and/or Local Emergency Dispatch Numbers for responding authorities. Upon receipt of an alarm signal, Company may, at our sole discretion, attempt to notify the Contacts to verify the signal is not false. If we fail to notify the Contacts or question the response we receive, we will attempt to notify the responding authority. In the event Company receives a supervisory signal or trouble signal, Company shall endeavor to promptly notify one of the Contacts. Company shall not be responsible for a Contact's or responding authority's refusal to acknowledge/respond to Company's notifications of receipt of an alarm signal, nor shall Company be required to make additional notifications because of such refusal. The Contacts are authorized to act on



Customer's behalf and, if so designated on the Contact/Call List, are authorized to cancel an alarm prior to the notification of authorities. Customer understands that local laws, ordinances or policies may restrict Company's ability to provide the alarm monitoring and notification services described in this Agreement and/or necessitate modified or additional services and related charges to Customer. Customer understands that Company may employ a number of industry-recognized measures to help reduce occurrences of false alarm signal activations. These measures may include, but are not limited to, implementation of industry-recognized default settings; implementation of "partial clear time bypass" procedures at our alarm monitoring center and other similar measures at our sole discretion from time to time. THESE MEASURES CAN RESULT IN NO ALARM SIGNAL BEING SENT FROM AN ALARM ZONE IN CUSTOMER'S PREMISES AFTER THE INITIAL ALARM ACTIVATION UNTIL THE ALARM SYSTEM IS MANUALLY RESET. Upon receiving notification from Company that a fire or gas detection (e.g. carbonmonoxide) signal has been received, the responding authority may forcibly enter the premises. Cellular radio unit test supervision, if provided under this Agreement, provides only the status of the cellular radio unit's current signaling ability at the time of the test communication based on certain programmed intervals and does not serve to detect the potential loss of radio service at the time of an actual emergency event. Company shall not be responsible to provide monitoring services under this Agreement unless and until the communication link between Customer's premises and Company's Monitoring Center has been tested. SUCH SERVICES ARE PROVIDED WITHOUT WARRANTY, EXPRESS OR IMPLIED, INCLUDING BUT NOT LIMITED TO ANY IMPLIED WARRANTIES OF MERCHANTABILITY OR FITNESS FOR A PARTICULAR PURPOSE.

B Limitation of Liability; Limitations of Remedy. Customer understands that Company offers several levels of Monitoring Services and that the level described has been chosen by Customer after considering and balancing various levels of protection afforded and their related costs. It is understood and agreed by Customer that Company is not an insurer and that insurance coverage shall be obtained by Customer and that amounts payable to Company hereunder are based upon the value of the Monitoring Services and the scope of liability set forth in this Agreement and are unrelated to the value of Customer's property and the property of others located on the premises. Customer agrees to look exclusively to Customer's insurer to recover for injuries or damage in the event of any loss or injury and that Customer releases and waives all right of recovery against Company arising by way of subrogation. Company makes no guaranty or warranty, including any implied warranty of merchantability or fitness for a particular purpose that equipment or Services supplied by Company will detect or avert occurrences or the consequences there from that the equipment or Service was designed to detect or avert. It is impractical and extremely difficult to fix the actual damages, if any, which may proximately result from failure on the part of Company to perform any of its monitoring obligations under this Agreement. Accordingly, Customer agrees that Company shall be exempt from liability for any loss, damage or injury arising directly or indirectly from occurrences, or the consequences therefrom, which the equipment or Service was designed to detect or avert. Should Company be found liable for any loss, damage or injury arising from a failure of the equipment or Service in any respect, Company's liability with respect to Monitoring Services shall be the lesser of the annual fee for

Monitoring Services allocable to the site where the incident occurred or two thousand five hundred (\$2,500) dollars, as agreed upon damages and not as a penalty, as Customer's sole remedy. Such sum shall be complete and exclusive. IN NO EVENT SHALL COMPANY BE LIABLE FOR ANY DAMAGE, LOSS, INJURY, OR ANY OTHER CLAIM ARISING FROM ANY SERVICING, ALTERATIONS, MODIFICATIONS, CHANGES, OR MOVEMENTS OF THE COVERED SYSTEM(S), AS HEREIN AFTER DEFINED, OR ANY OF ITS COMPONENT PARTS BY THE CUSTOMER OR ANY THIRD PARTY. In no event shall JCI and its affiliates and their respective personnel, suppliers and vendors be liable to Customer or any third party under any cause of action or theory of liability, even if advised of the possibility of such damages, for any (a) special, incidental, consequential, punitive or indirect damages of any kind, including but not limited to damages; (b) loss of profits, revenues, data, customer opportunities, business, anticipated savings or goodwill; (c) business interruption; or (d) data loss or other losses arising from viruses, ransomware, cyber-attacks or failures or interruptions to network systems CUSTOMER OR ANY THIRD PARTY. COMPANY SHALL NOT BE LIABLE FOR INDIRECT, INCIDENTAL OR CONSEQUENTIAL DAMAGES OF ANY KIND, INCLUDING BUT NOT LIMITED TO DAMAGES ARISING FROM THE USE, LOSS OF THE USE, PERFORMANCE, OR FAILURE OF THE COVERED SYSTEM(S) TO PERFORM. The limitations of liability set forth in this Agreement shall inure to the benefit of all parents, subsidiaries and affiliates of Company, whether direct or indirect, and each of their employees, agents, officers and directors.

C. Indemnity, Insurance. Customer agrees to indemnify, hold harmless and defend Company against any and all losses, damages, costs, including expert fees and costs, and expenses including reasonable defense costs, arising from any and all third-party claims for personal injury, death, property damage or economic loss, arising in any way from any act or omission of Customer or Company relating in any way to the Monitoring Services provided under this Agreement, whether such claims are based upon contract, warranty, tort (including but not limited to active or passive negligence), strict liability or otherwise. Company reserves the right to select counsel to represent it in any such action. Customer shall name Company, its officers, employees, agents, subcontractors, suppliers, and representatives as additional insureds on Customer's general liability and auto liability policies.

D. No modification. Modification to Sections 18 B or C may only be made by a written amendment to this Agreement signed by both parties specifically referencing Section 18 B and/or C, and no such amendment shall be effective unless approved by the manager of Company's Central Monitoring Center.

E. Customer's Duties. In addition to Customer's duty to indemnify, defend, and hold Company harmless pursuant to this Section 18:

i. Customer agrees to furnish the names and telephone numbers of all persons authorized to enter or remain on Customer's premises and/or that should be notified in the event of an alarm (the Contact/Call List) and Local Emergency Dispatch Numbers and provide all changes, revision and modifications to the above to Company in writing in a timely manner. Customer must ensure that all such persons are authorized and able to respond to such notification.

ii. Customer shall carefully and properly test and set the system immediately prior to the securing of the premises and carefully test the system in a manner prescribed by Company during the term of this Agreement. Customer agrees that it is responsible



for any losses or damages due to malfunction, miscommunication or failure of Customer's system to accurately handle, process or communicate data. If any defect in operation of the System develops, or in the event of a power failure, interruption of telephone service, or other interruption at Customer's premises of signal or data transmission through any media, Customer shall notify Company immediately. If space/interior protection (i.e. ultrasonic, microwave, infrared, etc.) is part of the System, Customer shall walk test the system in the manner recommended by Company.

iii. When any device or protection is used, including, but not limited to, space protection, which may be affected by turbulence of air, occupied airspace change or other disturbance, forced air heaters, air conditioners, horns, bells, animals and any other sources of air turbulence or movement which may interfere with the effectiveness of the System during closed periods while the alarm system is on, Customer shall notify Company

iv. Customer shall promptly reset the System after any activation.

v. Customer shall notify Company regarding any remodeling or other changes to the protected premises that may affect operation of the system.

vi. Customer shall cooperate with Company in the installation, operation and/or maintenance of the system and agrees to follow all instructions and procedures which may be prescribed for the operation of the system, the rendering of services and the provision of security for the premises.

vii. Customer shall pay all charges made by any telephone or communications provider company or other utility for installation, leasing, and service charges of telephone lines connecting Customer's premises to Company. Customer acknowledges that alarm signals from Customer's premises to Company are transmitted over Customer's telephone or other transmission service and that in the event the telephone or other transmission service is out of order, disconnected, placed on "vacation," or otherwise interrupted, signals from Customer's alarm system will not be received by Company, during any such interruption in telephone or other transmission service and the interruption will not be known to Company. Customer agrees that in the event the equipment or system continuously transmits signals reasonably determined by Company to be false and/or excessive in number, Customer shall be subject to the additional costs and fees incurred by Company in the receiving and/or responding to the excessive signals and/or Company may at its sole discretion terminate this Agreement with respect to Monitoring services upon notice to Customer.

F. Communication Facilities.

i. Authorization. Customer authorizes Company, on Customer's behalf, to request services, orders or equipment from a telephone company, wireless carrier or other company providing communication facilities, signal transmission services or facilities under this Agreement (referred to as "Communication Company"). Should any third-party service, equipment or facility be required to perform the Monitoring Services set forth in this Agreement, and should the same be terminated or become otherwise unavailable or impracticable to provide, Company may terminate Monitoring Services upon notice to Customer.

ii. Digital Communicator. Customer understands that a digital communicator (DACT), if installed under this Agreement, uses traditional telephone lines for sending signals which eliminate the need for a dedicated telephone line and the costs associated with such dedicated lines.

iii. Derived Local Channel. The Communication Company's services provided to Customer in connection with the Services may include Derived Local Channel service. Such service may be provided under the Communication Company's service marks or service names. These services include providing lines, signal paths, scanning and transmission. Customer agrees that the Communication Company's liability is limited to the same extent Company's liability is limited pursuant to this Section 18.

iv. CUSTOMER UNDERSTANDS THAT COMPANY WILL NOT RECEIVE ALARM SIGNALS WHEN THE TELEPHONE LINE OR OTHER TRANSMISSION MODE IS NOT OPERATING OR HAS BEEN CUT, INTERFERED WITH OR IS OTHERWISE DAMAGED OR IF THE ALARM SYSTEM IS UNABLE TO ACQUIRE, TRANSMIT OR MAINTAIN AN ALARM SIGNAL OVER CUSTOMER'S TELEPHONE SERVICE FOR ANY REASON INCLUDING NETWORK OUTAGE OR OTHER NETWORK PROBLEMS SUCH AS CONGESTION OR DOWNTIME, ROUTING PROBLEMS, OR INSTABILITY OF SIGNAL QUALITY. CUSTOMER UNDERSTANDS THAT OTHER POTENTIAL CAUSES OF SUCH A FAILURE OVER CERTAIN TELEPHONE SERVICES (INCLUDING BUT NOT LIMITED TO SOME TYPES OF DSL, ADSL, VOIP, DIGITAL PHONE, INTERNET PROTOCOL BASED PHONE OR OTHER INTERNET INTERFACE-TYPE SERVICE OR RADIO SERVICE, INCLUDING CELLULAR OR PRIVATE RADIO, ETC. ("NON-TRADITIONAL TELEPHONE SERVICE")) INCLUDE BUT ARE NOT LIMITED TO: (1) LOSS OF NORMAL ELECTRIC POWER TO CUSTOMER'S PREMISES (THE BATTERY BACK-UP FOR THE ALARM PANEL DOES NOT POWER TELEPHONE SERVICE); AND (2) ELECTRONICS FAILURES SUCH AS A MODEM MALFUNCTION. CUSTOMER UNDERSTANDS THAT COMPANY WILL ONLY REVIEW THE INITIAL COMPATIBILITY OF CUSTOMER'S ALARM SYSTEM WITH NON-TRADITIONAL TELEPHONE SERVICE AT THE TIME OF INITIAL CONNECTION TO COMPANY'S MONITORING CENTER AND THAT CHANGES IN CUSTOMER'S TELEPHONE SERVICE'S DATA FORMAT AFTER THE INITIAL REVIEW OF COMPATIBILITY COULD MAKE CUSTOMER'S TELEPHONE SERVICE UNABLE TO TRANSMIT ALARM SIGNALS TO COMPANY'S MONITORING CENTERS. IF COMPANY DETERMINES IN ITS SOLE DISCRETION THAT IT IS COMPATIBLE, COMPANY WILL PERMIT CUSTOMER TO USE NONTRADITIONAL TELEPHONE SERVICE AS THE SOLE METHOD OF TRANSMITTING ALARM SIGNALS, ALTHOUGH CUSTOMER UNDERSTANDS THAT COMPANY RECOMMENDS THE USE OF AN ADDITIONAL BACK-UP METHOD OF COMMUNICATION TO CONNECT CUSTOMER'S ALARM SYSTEM TO THE MONITORING CENTER REGARDLESS OF THE TYPE OF TELEPHONE SERVICE USED. CUSTOMER ALSO UNDERSTANDS THAT IF COMPANY DETERMINES IN ITS SOLE DISCRETION THAT CUSTOMER'S NONTRADITIONAL TELEPHONE SERVICE IS OR LATER BECOMES NONCOMPATIBLE, OR IF CUSTOMER CHANGES TO ANOTHER NONTRADITIONAL TELEPHONE SERVICE THAT IS NOT COMPATIBLE, THEN COMPANY REQUIRES THAT CUSTOMER USE AN ALTERNATE METHOD OF COMMUNICATION ACCEPTABLE TO COMPANY AS THE PRIMARY METHOD TO CONNECT CUSTOMER'S ALARM SYSTEM TO THE MONITORING CENTER. CUSTOMER UNDERSTANDS THAT TRANSMISSION OF FIRE ALARM SIGNALS BY MEANS OTHER THAN A TRADITIONAL TELEPHONE LINE MAY NOT BE IN COMPLIANCE WITH FIRE ALARM STANDARDS OR



SOME LOCAL FIRE CODES, AND THAT IT IS CUSTOMER'S OBLIGATION TO COMPLY WITH SUCH STANDARDS AND CODES. CUSTOMER ALSO UNDERSTANDS THAT IF THE ALARM SYSTEM HAS A LINECUT FEATURE, IT MAY NOT BE ABLE TO DETECT IF A NONTRADITIONAL TELEPHONE SERVICE LINE IS CUT OR INTERRUPTED, AND THAT COMPANY MAY NOT BE ABLE TO PROVIDE CERTAIN AUXILIARY MONITORING SERVICES THROUGH A NON-TRADITIONAL TELEPHONE LINE OR SERVICE. CUSTOMER FURTHER UNDERSTANDS THAT THE ALARM PANEL MAY BE UNABLE TO SEIZE THE PHONE LINE TO TRANSMIT AN ALARM SIGNAL IF ANOTHER CONNECTION IS OFF THE HOOK DUE TO IMPROPER CONNECTION OR OTHERWISE.

G. Verification; Runner Service. Some jurisdictions may require alarm verification by telephone or on-site verification ("Runner Service") before dispatching emergency services. In the event that a requirement of alarm verification becomes effective after the date of this Agreement, such services may be available at an additional charge. Company shall not be held liable for any delay or failure of dispatch of emergency services arising from such verification. Where Runner Service is indicated, such services may be provided by a third party. COMPANY WILL NOT ARREST OR DETAIN ANY PERSON.

H. Personal Emergency Response Service. If Customer has selected Personal Emergency Response Services, Customer agrees that the very nature of Personal Emergency Response Services, irrespective of any delays, involves uncertainty, risk and possible serious injury, disability or death, for which Company should not under any circumstances be held responsible or liable; that the equipment furnished for Personal Emergency Response Services is not foolproof and may experience signal transmission failures or delays for any number of reasons, whether or not our fault or under Company's control; that the actual time required for medical emergency providers to arrive at the premises and/or to transport any person requiring medical attention is unpredictable and that many contributing factors, including but not limited to such things as telephone network operation, distance, weather, road and traffic conditions, alarm equipment function and human factors, both with responding authorities and with Company, may affect response

19. Limited Warranty. COMPANY WARRANTS THAT ITS WORKMANSHIP AND MATERIAL, EXCLUDING MONITORING SERVICES, FURNISHED UNDER THIS AGREEMENT WILL BE FREE FROM DEFECTS FOR A PERIOD OF NINETY (90) DAYS FROM THE DATE OF FURNISHING. No warranty is provided for third-party products and equipment installed or furnished by Company. Such products and equipment are provided with the third party manufacturer's warranty to the extent available, and Company will transfer the benefits, together with all limitations, of that manufacturer's warranty to Customer. EXCEPT AS EXPRESSLY SET FORTH HEREIN, COMPANY DISCLAIMS ALL WARRANTIES, EXPRESS OR IMPLIED, INCLUDING BUT NOT LIMITED TO ANY IMPLIED WARRANTIES OF MERCHANTABILITY OR FITNESS FOR A PARTICULAR PURPOSE WITH RESPECT TO THE SERVICES PERFORMED OR THE PRODUCTS, SYSTEMS OR EQUIPMENT, IF ANY, SUPPORTED HERE UNDER. Company makes no and specifically disclaims all representations or warranties that the services, products, software or third party product or software will be secure from cyber threats, hacking or other similar malicious activity, or will detect the presence of, or eliminate, treat, or mitigate the spread transmission, or

outbreak of any pathogen, disease, virus or other contagion, including but not limited to COVID 19.

20. Software and Digital Services. Use, implementation, and deployment of the software and hosted software products ("Software") offered under these terms shall be subject to, and governed by, Company's standard terms for such Software and Software related professional services in effect from time to time at <https://www.johnsoncontrols.com/techterms> (collectively, the "Software Terms"). Applicable Software Terms are incorporated herein by this reference. Other than the right to use the Software as set forth in the Software Terms, Company and its licensors reserve all right, title, and interest (including all intellectual property rights) in and to the Software and improvements to the Software. The Software that is licensed hereunder is licensed subject to the Software Terms and not sold. If there is a conflict between the other terms herein and the Software Terms, the Software Terms shall take precedence and govern with respect to rights and responsibilities relating to the Software, its implementation and deployment and any improvements there to. Notwithstanding any other provisions of this Agreement and unless otherwise agreed to by the parties in writing, the following terms apply to Software that is provided to Customer on a subscription basis (i.e., a time limited license or use right), (each a "Software Subscription"): Each Software Subscription provided hereunder will commence on the date the initial credentials for the Software are made available (the "Subscription Start Date") and will continue in effect until the expiration of the subscription term noted herein. At the expiration of the Software Subscription, such Software Subscription will automatically renew for consecutive one (1) year terms (each a "Renewal Subscription Term"), unless either party provides the other party with a notice of non-renewal at least ninety (90) days prior to the expiration of the then-current term. To the extent permitted by applicable law, Software Subscriptions purchases are non-cancelable and the sums paid nonrefundable. Fees for Software Subscriptions shall be paid annually in advance, invoiced on the Subscription Start Date and each subsequent anniversary thereof. Unless otherwise agreed by the parties in writing, the subscription fee for each Renewal Subscription Term will be priced at JCI's then-applicable list price for that Software offering. Any use of Software that exceeds the scope, metrics or volume set forth in this Agreement will be subject to additional fees based on the date such excess use began.

21. Taxes, Fees, Fines, Licenses, and Permits. Customer agrees to pay all sales tax, use tax, property tax, utility tax and other taxes required in connection with the equipment and Services listed, including telephone company line charges, if any. Customer shall comply with all laws and regulations relating to the equipment and its use and shall promptly pay when due all sales, use, property, excise and other taxes and all permit, license and registration fees now or here after imposed by any government body or agency upon the equipment or its use. Company may, without notice, obtain any required permit, license or registration for Customer at Customer's expense and charge a fee for this service. If Customer fails to maintain any required licenses or permits, Company shall not be responsible for performing the services and may terminate the services without notice to Customer.

22. Outside Charges. Customer understands and accepts that Company specifically disclaims any responsibility for charges associated with the notification or dispatching of anyone, including but not limited to fire department, police department, paramedics, doctors, or any other emergency personnel, and if

there are any charges incurred as a result of said notification or dispatch, said charges shall be the responsibility of Customer.

23. Insurance. Customer shall name Company, its officers, employees, agents, subcontractors, suppliers, and representatives as additional insureds on Customer's general liability and auto liability policies.

24. Waiver of Subrogation. Customer does hereby for itself and all other parties claiming under it release and discharge Company from and against all hazards covered by Customer's insurance, it being expressly agreed and understood that no insurance company or insurer will have any right of subrogation against Company.

25. Force Majeure, Exclusions. Company shall not be liable, nor in breach or default of its obligations under this Agreement, for delays, interruption, failure to render services, or any other failure by Company to perform an obligation under this Agreement, where such delay, interruption or failure is caused, in whole or in part, directly or indirectly, by a Force Majeure Event. A "Force Majeure Event" is a condition or event that is beyond the reasonable control of Company, whether foreseeable or unforeseeable, including, without limitation, acts of God, severe weather (including but not limited to hurricanes, tornados, severe snowstorms or severe rainstorms), wildfires, floods, earthquakes, seismic disturbances, or other natural disasters, acts or omissions of any governmental authority (including change of any applicable law or regulation), epidemics, pandemics, disease, viruses, quarantines, or other public health risks and/or responses there to, condemnation, strikes, lockouts, labor disputes, an increase of 5% or more in tariffs or other excise taxes for materials to be used on the project, fires, explosions or other casualties, thefts, vandalism, civil disturbances, insurrection, mobviolence, riots, war or other armed conflict (or the serious threat of same), acts of terrorism, electrical power outages, interruptions or degradations in telecommunications, computer, network, or electronic communications systems, data breach, cyber-attacks, ransomware, unavailability or shortage of parts, materials, supplies, or transportation, or any other cause or casualty beyond the reasonable control of Company. If Company's performance of the work is delayed, impacted, or prevented by a Force Majeure Event or its continued effects, Company shall be excused from performance under the Agreement. Without limiting the generality of the foregoing, if Company is delayed in achieving one or more of the scheduled milestones set forth in the Agreement due to a Force Majeure Event, Company will be entitled to extend the relevant completion date by the amount of time that Company was delayed as a result of the Force Majeure Event, plus such additional time as may be reasonably necessary to overcome the effect of the delay. To the extent that the Force Majeure Event directly or indirectly increases Company's cost to perform the services, Customer is obligated to reimburse Company for such increased costs, including, without limitation, costs incurred by Company for additional labor, inventory storage, expedited shipping fees, trailer and equipment rental fees, subcontractor fees or other costs and expenses incurred by Company in connection with the Force Majeure Event.

26. Exclusions. This Agreement expressly excludes, without limitation, provision of fire watches; reloading of, upgrading, and maintaining computer software; making repairs or replacements necessitated by reason of negligence or misuse of components or equipment or changes to Customer's premises; vandalism; power failure; current fluctuation; failure due to non-JCI installation; lightning, electrical storm, or other severe weather; water; accident; fire; acts of God; testing

inspection and repair of duct detectors, beam detectors, and UV/IR equipment; provision of fire watches; clearing of ice blockage; draining of improperly pitched piping; batteries; recharging of chemical suppression systems; reloading of, upgrading, and maintaining computer software; corrosion (including but not limited to micro-bacterially induced corrosion ("MIC")); cartridges greater than 16 grams; gas valve installation; or any other cause external to the Covered System(s) and JCI shall not be required to provide Service while interruption of service due to such causes shall continue. This Agreement does not cover and specifically excludes system upgrades and the replacement of obsolete systems, equipment, components or parts. All such services may be provided by JCI at JCI's sole discretion at an additional charge. If Emergency Services are expressly included in the Service Solution, the Agreement price does not include travel expenses.

27. Delays. Company shall have no responsibility or liability to Customer or any other person for delays in the installation or repair of the System or the performance of our Services regardless of the reason, or for any resulting consequences.

28. Termination. If either party fails to perform any of its material obligations under this Agreement, the other party shall provide written notice thereof to the party alleged to be in default. Should the party alleged to be in default fail to respond in writing or take action to cure the alleged default within ten (10) days of receiving such written notice, the notifying party may terminate this Agreement by providing written notice of such termination. For termination prior to the end of the Term, Customer agrees to pay Company, in addition to any outstanding fees and charges for Service(s) rendered prior to termination, 50% of the charges for Services remaining to be paid for the unexpired term of the Agreement as liquidated damages but not as a penalty. Customer shall provide Company with reasonable access to the premises to remove any Company property and to un-program any controls, intrusion, fire, or life safety system, as applicable. Customer shall be liable for all fees, costs, and expenses that Company may incur in connection with the enforcement of this Agreement, including without limitation, reasonable attorney fees, collection agency fees, and court costs.

Upon notice to the customer, Company may terminate this Agreement immediately at its sole discretion upon the occurrence of any Event of Default as hereinafter defined. If Company's performance of its obligations becomes impracticable due to obsolescence or unavailability of systems, equipment, or products (including component parts and/or materials) or because the Company or its supplier(s) has discontinued the manufacture or the sale of the equipment and/or products or is no longer in the business of providing the Services, Company may terminate this Agreement, or the affected portions, at its sole discretion upon notice to Customer. Company may terminate this Agreement, or the affected portions, at its sole discretion upon notice to the Customer if Company's performance of its obligations are prohibited because of changes in applicable laws, regulations or codes. If Company receives an excessive number of false alarms, Company may terminate this Agreement and discontinue any Services, and seek to recover damages. If the equipment or system continuously sends signals that Company reasonably determines to be false or excessive, the Customer will be responsible for additional costs and fees incurred by Company in receiving and/or responding to these signals and/or Company may at its sole discretion terminate monitoring services under this Agreement upon notice to the Customer. Company may terminate this Agreement and discontinue any Service(s), if Company's central monitoring center ("CMC") or remote operations center or either of these centers is

substantially damaged by fire or catastrophe or if Company is unable to obtain any connections or privileges required to transmit signals between the Customer's premises, Company's CMC and/or the Municipal Fire or Police Department or other first responder. Company may terminate the Services immediately upon notice to the Customer if Company, in its sole discretion, determines the premises in which the Equipment or system is installed is unsafe, unsuitable, or so modified or altered as to render continuation of Service(s) impractical or impossible. Company may terminate the Services upon notice to the Customer, if Customer fails to follow Company's recommendations for the repair or replacement of parts of the system or Equipment not covered under the warranty or Service.

29. No Option to Solicit. Customer shall not, directly or indirectly, on its own behalf or on behalf of any other person, business, corporation or entity, solicit or employ any Company employee, or induce any Company employee to leave his or her employment with Company, for a period of two years after the termination of this Agreement.

30. Default. An Event of Default shall include, but is not limited to: (a) any full or partial termination of this Agreement by Customer before the expiration of the then-current Term, (b) failure of Customer to pay any amount when due and payable, (c) abuse of the System or the Equipment, (d) dissolution, termination, discontinuance, insolvency or business failure of Customer. Upon the occurrence of an Event of Default, Company may pursue one or more of the following remedies, (i) discontinue furnishing Services, (ii) by written notice to Customer declare the balance of unpaid amounts due and to become due under this Agreement to be immediately due and payable, (iii) receive immediate possession of any equipment for which Customer has not paid, (iv) proceed at law or equity to enforce performance by Customer or recover damages for breach of this Agreement, and (v) recover all costs and expenses, including without limitation reasonable attorneys' fees, in connection with enforcing or attempting to enforce this Agreement.

31. One-Year Limitation on Actions; Choice of Law. For Customers located in the United States, the laws of Wisconsin shall govern the validity, enforceability, and interpretation of this Agreement, without regard to conflicts of law. For Customers located in Canada, this agreement shall be governed by and be construed in accordance with the laws of Ontario. The parties agree that any disputes arising under this Agreement shall be determined exclusively by the Ontario courts and that no action or legal proceedings of any nature shall be filed or commenced in any other court pertaining to any dispute arising out of or in relation to this Agreement. The parties also hereby waive any objection to the exclusive jurisdiction of the Ontario courts, including any objection based on forum non conveniens. No claim or cause of action, whether known or unknown, shall be brought against Company more than one year after the claim first arose. Except as provided for herein, Company's claims must also be brought within one year. Claims for unpaid contract amounts are not subject to the one-year limitation.

32. Assignment. Customer may not assign this Agreement without Company's prior written consent. Company may assign this Agreement without obtaining Customer's consent.

33. Entire Agreement. The parties intend this Agreement, together with any attachments or Riders (collectively the "Agreement") to be the final, complete and exclusive expression of their Agreement and the terms and conditions thereof. This Agreement supersedes all prior representations, understandings or agreements between the parties, written or oral, and shall constitute the sole terms and

conditions relating to the Services. Now, or change, or modification of any terms or conditions of this Agreement shall be binding on Company unless made in writing and signed by an Authorized Representative of Company.

34. Headings. The headings in this Agreement are for convenience only.

35. Severability. If any provision of this Agreement is held by any court or other competent authority to be void or unenforceable in whole or in part, this Agreement will continue to be valid as to the other provisions and the remainder of the affected provision.

36. Electronic Media. Customer agrees that Company may scan, image or otherwise convert this Agreement into an electronic format of any nature. Customer agrees that a copy of this Agreement produced from such electronic format is legally equivalent to the original for any and all purposes, including litigation. Customer agrees that Company's receipt by fax of the Agreement signed by Customer legally binds Customer and such fax copy is legally equivalent to the original for any and all purposes, including litigation.

37. Legal Fees. Company shall be entitled to recover from Customer all reasonable legal fees incurred in connection with Company enforcing the terms and conditions of this Agreement.

38. Lien Legislation. Notwithstanding anything to the contrary contained herein, the terms of this Agreement shall be subject to the lien legislation applicable to the location where the work will be performed, and, in the event of conflict, the applicable lien legislation shall prevail.

39. Privacy. A. Company as Processor: Where Company factually acts as Processor of Personal Data on behalf of Customer (as such terms are defined in the DPA) the terms at www.johnsoncontrols.com/dpa shall apply. B. Company as Controller: Company will collect, process and transfer certain personal data of Customer and its personnel related to the business relationship between it and Customer (for example names, email addresses, telephone numbers) as controller and in accordance with Company's Privacy Notice at <https://www.johnsoncontrols.com/privacy>. Customer acknowledges Company's Privacy Notice and strictly to the extent consent is mandatorily required under applicable law, Customer consents to such collection, processing and transfer. To the extent consent to such collection, processing and transfer by Company is mandatorily required from Customer's personnel under applicable law, Customer warrants and represents that it has obtained such consent.

40. License Information (Security System Customers): AL Alabama Electronic Security Board of Licensure 7956 Vaughn Road, PMB 392, Montgomery, Alabama 36116 (334) 264-9388: AR Regulated by: Arkansas Board of Private Investigators and Private Security Agencies, #1 State Police Plaza Drive, Little Rock 72209 (501) 618-8600: CA Alarm company operators are licensed and regulated by the Bureau of Security and Investigative Services, Department of Consumer Affairs, Sacramento, CA, 95814. Upon completion of the installation of the alarm system, the alarm company shall thoroughly instruct the purchaser in the proper use of the alarm system. Failure by the licensee, without legal excuse, to substantially commence work within 20 days from the approximate date specified in the agreement when the work will begin is a violation of the Alarm Company Act: NY Licensed by the N.Y.S. Department of the State: TX Texas Commission on Private Security, 5805 N. Lamar Blvd., Austin, TX 78752-4422, 512-424-7710. License numbers available at www.johnsoncontrols.com or contact your local Johnson Controls office.

RESOLUTION NO.: _____ - 2026

OF

MAY 11, 2026

**A RESOLUTION AUTHORIZING CHANGE ORDER NO. 2G TO
THE CONSTRUCTION CONTRACT WITH BARONE CONSTRUCTION GROUP, INC.
FOR THE WASTEWATER TREATMENT PLANT ADMINISTRATION BUILDING
REHABILITATION PROJECT**

WHEREAS, by Resolution No. 263-2024 of December 9, 2024, the City Council of the City of Newburgh, New York awarded a bid to Barone Construction Group, Inc. in the amount of \$1,025,000.00 for the construction of the Wastewater Treatment Plant Administration Building Rehabilitation Project; and

WHEREAS, Barone Construction Group, Inc. has submitted Change Order No. 2G to provide a credit to the contract price in the amount of \$8,391.29 for unused contingency allowance and reduce the contract price to \$970,670.11; and

WHEREAS, the City Council has reviewed Change Order No. 2G and has determined that approving contract changes is in the best interest of the City of Newburgh;

NOW, THEREFORE, BE IT RESOLVED, by the Council of the City of Newburgh, New York that the City Manager be and he hereby is authorized to execute Change Order No. 2G with Barone Construction Group, Inc. for the Wastewater Treatment Plant Administration Building Rehabilitation Project.

Jason Morris, P.E.
Commissioner of Public Works and City Engineer
City of Newburgh
83 Broadway
Newburgh, NY 12550

Arcadis of New York, Inc.
646 Plank Road, Suite 100
Clifton Park, NY 12065
United States
Phone: 518 250 7300
www.arcadis.com

Date: April 23, 2026
Our Ref: 30251957
Subject: Wastewater Treatment Plant Admin Building Renovation
General Contract (1G): Change Order No. 2

Dear Mr. Morris,

Attached is Change Order No. 2 for the General Contract associated with the Wastewater Treatment Plant Administration Building Renovation Project. This change order represents the final balance adjustment for Contract 1G, resulting in a credit of \$8,391.39 for the unused contingency allowance.

A summary of the contingency allowance is provided below:

- Allowance Authorization No. GC-001: (\$9,081.60)
- Allowance Authorization No. GC-002: (\$11,419.93)
- Allowance Authorization No. GC-003: (\$35,639.86)
- Allowance Authorization No. GC-004: (\$3,242.61)
- Allowance Authorization No. GC-005: (\$6,502.81)
- Allowance Authorization No. GC-006: (\$721.80)

Total Allowance Used: (\$66,608.61)
Original Allowance: \$75,000.00
Remaining Allowance: \$8,391.39

The original contract amount was \$1,025,000.00. Change Order No. 1 reduced the contract by (\$45,938.50), resulting in a revised total of \$979,061.50. This Change Order No. 2 further reduces the contract by (\$8,391.39), bringing the final contract amount to \$970,670.11.

Please feel free to contact me if you have any questions or require additional information.

Sincerely,
Arcadis of New York, Inc.



Kyle Kortright, PE
Resident Engineer

Email: kyle.kortright@arcadis.com
Mobile: 845-399-0013

Enclosures: Admin Building - GC Change Order No. 2 – Partially Executed

| | |
|---|---|
| Date of Issuance: 4/24/2026 | Effective Date: 4/ /2026 |
| Owner: City of Newburgh | Owner's Contract No.: 7.24 – PO#36849 |
| Contractor: Barone Construction Group, Inc. | Contractor's Project No.: GC-24-110 |
| Engineer: Arcadis of New York, Inc. | Engineer's Project No.: 30251957 |
| Project: WWTP Admin Building Renovation | Contract Name: 1-G - General Construction |

The Contract is modified as follows upon execution of this Change Order:

Description:

This change order serves as the final balancing change order for the contract and reduces the contract price by \$8,391.39 for the unused contingency allowance.

Attachments: None

| CHANGE IN CONTRACT PRICE | CHANGE IN CONTRACT TIMES |
|---|--|
| Original Contract Price: <u>\$1,025,000.00</u> | Original Contract Times: Substantial Completion: <u>February 3, 2026</u> Ready for Final Payment: <u>March 5, 2026</u> days or dates |
| Decrease from previously approved Change Orders No. <u>0</u> to No. <u>1</u> : <u>-\$45,938.50</u> | Increase from previously approved Change Orders No. <u>0</u> to No. <u>1</u> : Substantial Completion: <u>0</u> Ready for Final Payment: <u>0</u> days |
| Contract Price prior to this Change Order: <u>\$979,061.50</u> | Contract Times prior to this Change Order: Substantial Completion: <u>February 3, 2026</u> Ready for Final Payment: <u>March 5, 2026</u> days or dates |
| Decrease of this Change Order: <u>-\$8,391.39</u> | Increase of this Change Order: Substantial Completion: <u>0</u> Ready for Final Payment: <u>0</u> days or dates |
| Contract Price incorporating this Change Order: <u>\$970,670.11</u> | Contract Times with all approved Change Orders: Substantial Completion: <u>February 3, 2026</u> Ready for Final Payment: <u>March 5, 2026</u> days or dates |

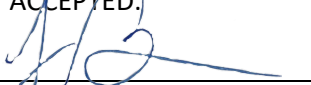
| | | | | | |
|--|------------------------------|--|--|------------------|--|
| RECOMMENDED: | | ACCEPTED: | | ACCEPTED: | |
| By: <u></u> | By: _____ | By: <u></u> | | | |
| Engineer (if required) | Owner (Authorized Signature) | Contractor (Authorized Signature) | | | |
| Title: <u>Resident Engineer</u> | Title _____ | Title <u>President</u> | | | |
| Date: <u>4/23/2026</u> | Date _____ | Date <u>4/23/2026</u> | | | |

Jason Morris, P.E.
Commissioner of Public Works and City Engineer
City of Newburgh
83 Broadway
Newburgh, NY 12550

Arcadis of New York, Inc.
646 Plank Road, Suite 100
Clifton Park, NY 12065
United States
Phone: 518 250 7300
www.arcadis.com

Date: April 23, 2026
Our Ref: 30251957
Subject: Wastewater Treatment Plant Admin Building Renovation
General Contract (1G): Change Order No. 2

Dear Mr. Morris,

Attached is Change Order No. 2 for the General Contract associated with the Wastewater Treatment Plant Administration Building Renovation Project. This change order represents the final balance adjustment for Contract 1G, resulting in a credit of \$8,391.39 for the unused contingency allowance.

A summary of the contingency allowance is provided below:

- Allowance Authorization No. GC-001: (\$9,081.60)
- Allowance Authorization No. GC-002: (\$11,419.93)
- Allowance Authorization No. GC-003: (\$35,639.86)
- Allowance Authorization No. GC-004: (\$3,242.61)
- Allowance Authorization No. GC-005: (\$6,502.81)
- Allowance Authorization No. GC-006: (\$721.80)

Total Allowance Used: (\$66,608.61)
Original Allowance: \$75,000.00
Remaining Allowance: \$8,391.39

The original contract amount was \$1,025,000.00. Change Order No. 1 reduced the contract by (\$45,938.50), resulting in a revised total of \$979,061.50. This Change Order No. 2 further reduces the contract by (\$8,391.39), bringing the final contract amount to \$970,670.11.

Please feel free to contact me if you have any questions or require additional information.

Sincerely,
Arcadis of New York, Inc.



Kyle Kortright, PE
Resident Engineer

Email: kyle.kortright@arcadis.com
Mobile: 845-399-0013

Enclosures: Admin Building - GC Change Order No. 2 – Partially Executed

| | |
|---|---|
| Date of Issuance: 4/24/2026 | Effective Date: 4/ /2026 |
| Owner: City of Newburgh | Owner's Contract No.: 7.24 – PO#36849 |
| Contractor: Barone Construction Group, Inc. | Contractor's Project No.: GC-24-110 |
| Engineer: Arcadis of New York, Inc. | Engineer's Project No.: 30251957 |
| Project: WWTP Admin Building Renovation | Contract Name: 1-G - General Construction |

The Contract is modified as follows upon execution of this Change Order:

Description:

This change order serves as the final balancing change order for the contract and reduces the contract price by \$8,391.39 for the unused contingency allowance.

Attachments: None

| CHANGE IN CONTRACT PRICE | CHANGE IN CONTRACT TIMES |
|---|--|
| Original Contract Price: <u>\$1,025,000.00</u> | Original Contract Times: Substantial Completion: <u>February 3, 2026</u> Ready for Final Payment: <u>March 5, 2026</u> days or dates |
| Decrease from previously approved Change Orders No. <u>0</u> to No. <u>1</u> : <u>-\$45,938.50</u> | Increase from previously approved Change Orders No. <u>0</u> to No. <u>1</u> : Substantial Completion: <u>0</u> Ready for Final Payment: <u>0</u> days |
| Contract Price prior to this Change Order: <u>\$979,061.50</u> | Contract Times prior to this Change Order: Substantial Completion: <u>February 3, 2026</u> Ready for Final Payment: <u>March 5, 2026</u> days or dates |
| Decrease of this Change Order: <u>-\$8,391.39</u> | Increase of this Change Order: Substantial Completion: <u>0</u> Ready for Final Payment: <u>0</u> days or dates |
| Contract Price incorporating this Change Order: <u>\$970,670.11</u> | Contract Times with all approved Change Orders: Substantial Completion: <u>February 3, 2026</u> Ready for Final Payment: <u>March 5, 2026</u> days or dates |

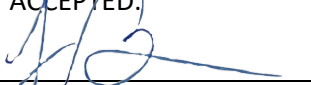
| | | |
|--|------------------------------|--|
| RECOMMENDED: | ACCEPTED: | ACCEPTED: |
| By: <u></u> | By: _____ | By: <u></u> |
| Engineer (if required) | Owner (Authorized Signature) | Contractor (Authorized Signature) |
| Title: <u>Resident Engineer</u> | Title _____ | Title <u>President</u> |
| Date: <u>4/23/2026</u> | Date _____ | Date <u>4/23/2026</u> |

RESOLUTION NO.: _____ - 2026

OF

MAY 11, 2026

**A RESOLUTION AUTHORIZING CHANGE ORDER NO. 1 TO
THE ELECTRICAL CONTRACT WITH EJ ELECTRIC INSTALLATION CO.
FOR THE WASTEWATER TREATMENT PLANT ADMINISTRATION BUILDING
REHABILITATION PROJECT**

WHEREAS, by Resolution No. 264-2024 of December 9, 2024, the City Council of the City of Newburgh, New York awarded a bid to E-J Electric Installation Co. in the amount of \$254,254.00 for the electrical construction of the Wastewater Treatment Plant Administration Building Rehabilitation Project; and

WHEREAS, E-J Electric Installation Co. has submitted Change Order No. 1 to provide a credit to the contract price in the amount of \$33,542.14 for unused contingency allowance and reduce the contract price to \$220,711.86; and

WHEREAS, the City Council has reviewed Change Order No. 1 and has determined that approving contract changes is in the best interest of the City of Newburgh;

NOW, THEREFORE, BE IT RESOLVED, by the Council of the City of Newburgh, New York that the City Manager be and he hereby is authorized to execute Change Order No. 1 with E-J Electric Installation Co. for the Wastewater Treatment Plant Administration Building Rehabilitation Project.

Jason Morris, P.E.
Commissioner of Public Works and City Engineer
City of Newburgh
83 Broadway
Newburgh, NY 12550

Arcadis of New York, Inc.
646 Plank Road, Suite 100
Clifton Park, NY 12065
United States
Phone: 518 250 7300
www.arcadis.com

Date: April 23, 2026
Our Ref: 30251957
Subject: Wastewater Treatment Plant Admin Building Renovation
Electrical Contract (2E): Change Order No. 1

Dear Mr. Morris,

Attached is Change Order No. 1 for the Electrical Contract associated with the Wastewater Treatment Plant Administration Building Renovation Project. This change order represents the final balance adjustment for Contract 2E, resulting in a credit of \$33,542.14 for the unused contingency allowance.

A summary of the contingency allowance is provided below:

- Allowance Authorization No. EC-001: (\$9,253.03)
- Allowance Authorization No. EC-002: (\$7,204.83)

Total Allowance Used: (\$16,457.86)
Original Allowance: \$50,000.00
Remaining Allowance: \$33,542.14

The original contract amount was \$254,254.00. As this is the first and only change order, the revised contract total is \$220,711.86.

Please feel free to contact me if you have any questions or require additional information.

Sincerely,
Arcadis of New York, Inc.



Kyle Kortright, PE
Resident Engineer

Email: kyle.kortright@arcadis.com
Mobile: 845-399-0013

Enclosures: Admin Building - EC Change Order No. 1 – Partially Executed

Date of Issuance: 4/23/2026
 Owner: City of Newburgh
 Contractor: E-J Electric Installation Co.
 Engineer: Arcadis of New York, Inc.
 Project: WWTP Admin Building Renovation

Effective Date: 4/ /2026
 Owner's Contract No.: 7.24 – PO#37491
 Contractor's Project No.: 240822
 Engineer's Project No.: 30251957
 Contract Name: 2-E – Electrical
 Construction

The Contract is modified as follows upon execution of this Change Order:

Description:
 This change order serves as the final balancing change order for the contract and reduces the contract price by \$33,542.14 for the unused contingency allowance.

Attachments: None

| CHANGE IN CONTRACT PRICE | CHANGE IN CONTRACT TIMES |
|--|--|
| Original Contract Price: \$254,254.00 | Original Contract Times: Substantial Completion: February 3, 2026 Ready for Final Payment: March 5, 2026 days or dates |
| Increase from previously approved Change Orders No. 0 to No. 0 : \$0.00 | Increase from previously approved Change Orders No. 0 to No. 0 : Substantial Completion: 0 Ready for Final Payment: 0 days |
| Contract Price prior to this Change Order: \$254,254.00 | Contract Times prior to this Change Order: Substantial Completion: February 3, 2026 Ready for Final Payment: March 5, 2026 days or dates |
| Decrease of this Change Order: (\$33,542.14) | Increase of this Change Order: Substantial Completion: 0 Ready for Final Payment: 0 days or dates |
| Contract Price incorporating this Change Order: \$220,711.86 | Contract Times with all approved Change Orders: Substantial Completion: February 3, 2026 Ready for Final Payment: March 5, 2026 days or dates |

| | | | | | |
|-------------------------------|------------------------------|-----------------------------------|--------------|-----------------------------------|--------------|
| RECOMMENDED: | | ACCEPTED: | | ACCEPTED: | |
| By: <u><i>[Signature]</i></u> | By: _____ | By: <u><i>[Signature]</i></u> | By: _____ | By: <u><i>[Signature]</i></u> | By: _____ |
| Engineer (if required) | Owner (Authorized Signature) | Contractor (Authorized Signature) | | Contractor (Authorized Signature) | |
| Title: Resident Engineer | Title: _____ | Title: <u>GM</u> | Title: _____ | Title: _____ | Title: _____ |
| Date: 4/6/2026 | Date: _____ | Date: <u>4/13/26</u> | Date: _____ | Date: _____ | Date: _____ |

RESOLUTION NO.: _____ - 2026

OF

MAY 11, 2026

**A RESOLUTION AUTHORIZING CHANGE ORDER NO. 1 TO
THE HVAC CONTRACT WITH DJ HEATING & AIR CONDITIONING, INC.
FOR THE WASTEWATER TREATMENT PLANT ADMINISTRATION BUILDING
REHABILITATION PROJECT**

WHEREAS, by Resolution No. 265-2024 of December 9, 2024, the City Council of the City of Newburgh, New York awarded a bid to DJ Heating & Air Conditioning, Inc. in the amount of \$458,000.00 for the HVAC construction of the Wastewater Treatment Plant Administration Building Rehabilitation Project; and

WHEREAS, DJ Heating & Air Conditioning, Inc. has submitted Change Order No. 1 to provide a credit to the contract price in the amount of \$17,910.52 for unused contingency allowance and reduce the contract price to \$440,089.48; and

WHEREAS, the City Council has reviewed Change Order No. 1 and has determined that approving contract changes is in the best interest of the City of Newburgh;

NOW, THEREFORE, BE IT RESOLVED, by the Council of the City of Newburgh, New York that the City Manager be and he hereby is authorized to execute Change Order No. 1 with DJ Heating & Air Conditioning, Inc. for the Wastewater Treatment Plant Administration Building Rehabilitation Project.

Jason Morris, P.E.
Commissioner of Public Works and City Engineer
City of Newburgh
83 Broadway
Newburgh, NY 12550

Arcadis of New York, Inc.
646 Plank Road, Suite 100
Clifton Park, NY 12065
United States
Phone: 518 250 7300
www.arcadis.com

Date: April 23, 2026
Our Ref: 30251957
Subject: Wastewater Treatment Plant Admin Building Renovation
HVAC Contract (3H): Change Order No. 1

Dear Mr. Morris,

Attached is Change Order No. 1 for the HVAC Contract associated with the Wastewater Treatment Plant Administration Building Renovation Project. This change order represents the final balance adjustment for Contract 3H, resulting in a credit of \$17,910.52.

This credit is comprised of the following:

1. \$1,817.72 for the revision to the duct insulation jacketing material
2. \$16,092.80 for the unused contingency allowance

A summary of the contingency allowance is provided below:

- Allowance Authorization No. HC-001: (\$709.92)
- Allowance Authorization No. HC-002: (\$4,412.03)
- Allowance Authorization No. HC-003: (\$3,785.25)

Total Allowance Used: (\$8,907.20)
Original Allowance: \$25,000.00
Remaining Allowance: \$16,092.80

The original contract amount was \$458,000.00. This Change Order No. 1 reduces the contract amount by \$17,910.52, bringing the final contract amount to \$440,089.48.

Please feel free to contact me if you have any questions or require additional information.

Sincerely,
Arcadis of New York, Inc.



Kyle Kortright, PE
Resident Engineer

Email: kyle.kortright@arcadis.com
Mobile: 845-399-0013

Enclosures: Admin Building - HC Change Order No. 1 – Partially Executed

Date of Issuance: 4/23/2026
 Owner: City of Newburgh
 Contractor: DJ Heating & Air Conditioning, Inc.
 Engineer: Arcadis of New York, Inc.
 Project: WWTP Admin Building Renovation

Effective Date:
 Owner's Contract No.: 7.24 – PO#37494
 Contractor's Project No.: 24-237
 Engineer's Project No.: 30251957
 Contract Name: 3-H – HVAC
 Construction



The Contract is modified as follows upon execution of this Change Order:

Description:

This change order serves as the final balancing change order for the contract and reduces the contract price by \$17,910.52, including a credit of (\$1,817.72) for revising the exterior duct insulation jacketing material and (\$16,092.80) for the unused contingency allowance.

Attachments: Proposal Request No. HC-005, Contractor's Change Order Proposal No. HC-005

| CHANGE IN CONTRACT PRICE | CHANGE IN CONTRACT TIMES |
|---|--|
| Original Contract Price: \$458,000.00 | Original Contract Times: Substantial Completion: <u>February 3, 2026</u> Ready for Final Payment: <u>March 5, 2026</u> days or dates |
| Increase from previously approved Change Orders No. <u>0</u> to No. <u>0</u> : \$0.00 | Increase from previously approved Change Orders No. <u>0</u> to No. <u>0</u> : Substantial Completion: <u>0</u> Ready for Final Payment: <u>0</u> days |
| Contract Price prior to this Change Order: \$458,000.00 | Contract Times prior to this Change Order: Substantial Completion: <u>February 3, 2026</u> Ready for Final Payment: <u>March 5, 2026</u> days or dates |
| Decrease of this Change Order: (\$17,910.52) | Increase of this Change Order: Substantial Completion: <u>0</u> Ready for Final Payment: <u>0</u> days or dates |
| Contract Price incorporating this Change Order: \$440,089.48 | Contract Times with all approved Change Orders: Substantial Completion: <u>February 3, 2026</u> Ready for Final Payment: <u>March 5, 2026</u> days or dates |

| | | | |
|--|------------------------------|--|--------------|
| RECOMMENDED: | | ACCEPTED: | |
| By: <u></u> | By: _____ | By: <u></u> | By: _____ |
| Engineer (if required) | Owner (Authorized Signature) | Contractor (Authorized Signature) | |
| Title: <u>Resident Engineer</u> | Title: _____ | Title: <u>Vice President</u> | Title: _____ |
| Date: <u>3/26/2026</u> | Date: _____ | Date: <u>3/26/2026</u> | Date: _____ |

Proposal Request No. HC-005

PROPOSAL REQUEST

Owner: City of Newburgh

Project Name: WWTP Admin Building Renovation

Proposal Request No.: HC-005 Date: 1/19/2026

Contract Name and No.: Contract 3-H, HVAC Construction

Contractor: DJ Heating & Air Conditioning, Inc.

Other Contracts Involved in Proposed Change: _____

TO CONTRACTOR: Please submit a complete Change Proposal for the proposed modifications described below. If the associated Change Proposal is approved, a Change Order or allowance authorization will be issued to authorize adjustment to the scope of the Work. This Proposal Request is not a Change Order, Work Change Directive, Field Order, or an authorization to proceed with the proposed Work described below.

SCOPE OF PROPOSED WORK:

The Contract Documents require that all exterior ductwork be insulated and provided with stainless steel protective jacketing. The Contract Documents further require that all exterior DX piping insulation be wrapped with stainless steel protective jacketing.

It has been noted that 3M VentureClad jacketing was accepted and installed in lieu of the specified stainless steel jacketing for the exterior ductwork and DX piping insulation.

Accordingly, please submit a credit proposal reflecting the material cost difference between the installed 3M VentureClad jacketing and the specified stainless steel protective jacketing.

Proposal requested by: Kyle Kortright

Signature of Requestor: 

Contractor's Change Order Proposal No. HC-005

DJ Heating & Air Conditioning, Inc.
1409 Route 9W,
Marlboro, NY 12542
(845) 236-4436

**DJ Heating &
Air Conditioning, Inc.**

Change Order

To: Kyle Kortright at Arcadis

Date: 3/24/26

Re: Change Order 5 – Exterior Jacketing Credit

Please see the attached quotes from DJ Heating's mechanical insulator, "Blackbird – Stainless Quote" and "Blackbird – Venture Clad Quote," and his supplier's quote "General Insulation Quote" summarizing the material credit for substituting aluminum jacketing for stainless steel jacketing. Please also see attached "Exterior Jacketing Credit - COE" document Change Order Estimate sheet for mark-ups, warranty, and bond costs added to our subcontractor's proposal.

Total CREDIT for Proposed Change Order 5: -\$1,817.72

Thank you,

Vincent Pomarico

DJ Heating & Air Conditioning Inc
1409 Route 9W
Marlboro NY 12542

PROPOSAL
Blackbird Mechanical Insulation Inc

25 Mountainside Road, WARWICK, NY 10990

530-574-1161

blackbirdinsulation@gmail.com

| | | |
|--|--------------------------------|-------------------|
| PROPOSAL SUBMITTED TO DJ Heating & Air Conditioning, Inc./ Vincent Pomarico | PHONE 845.236.4436 | DATE 3/18/2026 |
| JOB NAME Newburgh WWTP Change Order | JOB LOCATION | |
| CITY Newburgh | STATE AND ZIP CODE New York | |
| DATE OF PLANS | SHEET NUMBER | |

material price differences-

1RL 3M VCLAD EM-JKT EMB. ALUM 35.5" X 150' 1577CWE-EMJ- \$695.640/RL

2 rolls- \$1391.26

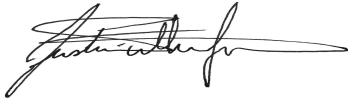
| |
|--|
| <p>We propose hereby to furnish material and labor - complete in accordance with the above specifications for the sum of:</p> <div style="text-align: center; margin: 10px 0;">  </div> <p>Authorized Signature:</p> |
| <p>Note: this proposal may be withdrawn by us if not accepted within 45 days.</p> |

PROPOSAL
Blackbird Mechanical Insulation Inc

25 Mountainside Road, WARWICK, NY 10990

530-574-1161

blackbirdinsulation@gmail.com

| | | |
|--|--------------------------------|-------------------|
| PROPOSAL SUBMITTED TO DJ Heating & Air Conditioning, Inc./ Vincent Pomarico | PHONE 845.236.4436 | DATE 3/18/2026 |
| JOB NAME Newburgh WWTP Change Order | JOB LOCATION | |
| CITY Newburgh | STATE AND ZIP CODE New York | |
| DATE OF PLANS | SHEET NUMBER | |

material price differences-
 .016 x 36" x 50' T-304 Smooth Stainless Steel \$768.00/rl
 4-rolls, \$3072.00

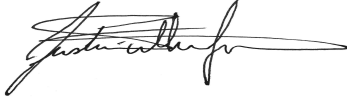
| |
|---|
| <p>We propose hereby to furnish material and labor - complete in accordance with the above specifications for the sum of:</p> <div style="text-align: center; margin: 10px 0;">  </div> <p>Authorized Signature:</p> |
| <p>Note: this proposal may be withdrawn by us if not accepted within 45 days.</p> |
| |



Quotation

GENERAL INSULATION/ALBANY BRANCH
 15 KAIRNES STREET
 ALBANY, NY 12205-5310
 Phone 518-489-9891
 Fax 518-453-0457

| | |
|--|--------------|
| EXPIRATION DATE | QUOTE NUMBER |
| 03/20/2026 | S7206643 |
| GENERAL INSULATION/ALBANY BRANCH 15 KAIRNES STREET ALBANY, NY 12205-5310 Phone 518-489-9891 Fax 518-453-0457 | |
| PAGE NO. 1 of 1 | |

QUOTE TO:

SHIP TO:

BLACKBIRD INSULATION, LLC
 25 MOUNTAINSIDE ROAD
 WARWICK, NY 10990-2240

BLACKBIRD INSULATION, LLC
 25 MOUNTAINSIDE ROAD
 WARWICK, NY 10990-2240

| CUSTOMER NUMBER | CUSTOMER PO NUMBER | JOB NAME / RELEASE NUMBER | SALESPERSON | |
|-----------------|---|---------------------------|-----------------|-----------------|
| 41894 | | | Jim Sausville 9 | |
| WRITER | SHIP VIA | TERMS | SHIP DATE | FREIGHT ALLOWED |
| Tony Roy 9 | OT OUR TRUCK | Net 30 | 02/03/2026 | No |
| ORDER QTY | DESCRIPTION | | UNIT PRICE | EXT PRICE |
| | SHIPPING INSTRUCTIONS "JUSTIN CELL 1-530-574-1161" | | | |
| 1RL | 3M VCLAD EM-JKT EMB. ALUM 35.5" X 150' 1577CWE-EMJ (1RL/BX) #7100311499 Pn: 117874 | | 695.640/RL | 695.64 |
| 1rl | .016 T-304 JKTG SM W/MB COS this is smooth Pn: 938 | | 768.000/ea | 768.00 |

NOTE: If material is for an exempt Job please provide Exempt Certificate and Full address of Job or provide a Resale Certificate.
 :
 Descriptions, quantities and sized are not guaranteed. To avoid errors, plans and specifications should be verified. Special Materials are non-refundable. We are not responsible for delays by reason of strikes, accidents or causes beyond our control. No Claims for Labor or consequential damages will be allowed.

| | |
|------------|--|
| Subtotal | |
| Freight | |
| Handling | |
| Sales Tax | |
| Amount Due | |

RESOLUTION NO.: _____ - 2026

OF

MAY 11, 2026

**A RESOLUTION AUTHORIZING CHANGE ORDER NO. 1 TO
THE CONSTRUCTION CONTRACT
WITH VERDE ELECTRIC MAINTENANCE CORPORATION IN
THE BROADWAY PEDESTRIAN AND TRAFFIC SIGNALS IMPROVEMENTS PROJECT
(PIN #8005.26 AND PIN#8758.75)**

WHEREAS, by Resolution No. 231-2024 of November 12, 2024, the City Council of the City of Newburgh, New York awarded a bid to Verde Electric Maintenance Corporation in the amount of \$6,803,703.96 for the construction of the Broadway Pedestrian and Traffic Signals Improvements Project (PIN#8005.26 and PIN#8758.75); and

WHEREAS, Verde Electric Maintenance Corporation has submitted Change Order No. 1 to the construction contract adding \$988,968.04 for additional work related to stamped colored concrete, colored curb ramp ground mounted traffic signal cabinet bases, and utility conflicts; and

WHEREAS, funding for Change Order No. 1 will be derived from a federal aid local agreement with the New York State Department of Transportation (NYSDOT) providing an 80% grant and 20% local match from the City's allocation of NYSDOT CHIPS funds; the same being in the best interests of the City of Newburgh;

NOW, THEREFORE, BE IT RESOLVED, by the Council of the City of Newburgh, New York that the City Manager be and he hereby is authorized to execute Change Order No. 1 with Verde Electric Maintenance Corporation increasing the total contract amount by \$988,968.04 from \$6,803,703.96 to \$7,792,671.30 in the Broadway Pedestrian and Traffic Signals Improvements Project (PIN#8005.26 and PIN#8758.75).



WSP USA
500 Summit Lake Drive
Suite 450
Valhalla, NY 10595

Tel: 914 747 1120
Fax: 914 747 1956

wsp.com

April 27, 2026

City of Newburgh
83 Broadway
Newburgh, NY 11550

Attn. Mr. Chad M. Wade, R.L.A. Superintendent of Public Works
City of Newburgh Engineer, Sponsor

*Re: Project: PIN No. 8005.26 and 8758.75 Broadway Pedestrian and Traffic Signal Improvements
City of Newburgh, Orange County, New York
Change Order 001 w/Verde Construction*

Dear Mr. Wade

WSP recommends acceptance of Change Order 001 with Verde Construction for a net increase to the contract of \$988,968.04 for additional work including stamped colored concrete, colored curb ramps, ground mounted traffic signal cabinet bases and additional work related to utility conflicts. The additional project costs are being offset by project savings through the reduction in unit items, and from additional grant funds secured by the City from the Orange County Transportation Council. The additional costs associated with this change order will result in a revised contract amount of \$7,792,671.30.

Please find attached the following:

1. CONR 104 – Authorization of Extra Work
2. Appia Change Order 001 Details
3. CO 001 Analysis Sheet
4. Verde Agreed Price Packages

Very truly yours,
WSP USA Inc.

Arlisa McGrath, Resident Engineer

cc: Peter S. Mancuso, PE, PTOE, WSP
File: Verde Electric CO 001



WSP - Valhalla

Change Order Details

PINS 8005.26 & 8758.75 BROADWAY PTS

| | |
|----------------------------------|--|
| Description | CITY OF NEWBURGH PINS 8005.26 & 8758.75 BROADWAY PEDESTRIAN AND TRAFFIC SIGNAL IMPROVEMENTS |
| Prime Contractor | Verde Electric |
| Change Order | 1 |
| Status | Pending |
| Date Created | 06/18/2025 |
| Type | Added work to contract |
| Summary | New Items |
| Change Order Description | This Change Order is being created to add new item for test pits at proposed Traffic Signal Foundations due to existing underground utility conflicts unknown at time of design as well as a new item for Microcomputer Traffic Control Cabinet Bases due to a design change to install the Traffic Signal Cabinets on the ground in lieu of on the Traffic Signal Poles and a new item for changing curb ramps to include colored concrete at locations within the historical district of Newburgh. |
| Awarded Project Amount | \$6,803,703.26 |
| Authorized Project Amount | \$6,803,703.26 |
| Change Order Amount | \$988,968.04 |
| Revised Project Amount | \$7,792,671.30 |

Increases/Decreases

| Line Number | Item ID | Unit | Unit Price | Current | | Change | | Revised | |
|-------------|---------|------|------------|----------|--------|----------|--------|----------|--------|
| | | | | Quantity | Amount | Quantity | Amount | Quantity | Amount |

Section: 1 - Share #1

| | | | | | | | | | |
|---------------------|--------|----|----------|---------|------------|----------|-------------|-------|--------|
| 0080 | 207.22 | SY | \$18.090 | 402.800 | \$7,286.65 | -402.800 | -\$7,286.65 | 0.000 | \$0.00 |
| GEOTEXTILE DRAINAGE | | | | | | | | | |

Reason: This decrease to the contract quantity is due to the elimination of this item from the contract.

Funding Details

| | | | | | | |
|-----------|---------|------------|----------|-------------|-------|--------|
| Share # 1 | 402.800 | \$7,286.65 | -402.800 | -\$7,286.65 | 0.000 | \$0.00 |
| Share # 2 | 0.000 | \$0.00 | 0.000 | \$0.00 | 0.000 | \$0.00 |

| | | | | | | | | | |
|---|-------|----|----------|---------|-------------|----------|--------------|-------|--------|
| 0180 | 490.3 | SY | \$75.370 | 258.400 | \$19,475.61 | -258.400 | -\$19,475.61 | 0.000 | \$0.00 |
| MISCELLANEOUS COLD MILLING OF BITUMINOUS CONCRETE | | | | | | | | | |

Reason: This decrease to the contract quantity is the result of the elimination of this work from the contract.

Funding Details

| | | | | | | |
|-----------|---------|-------------|----------|--------------|-------|--------|
| Share # 1 | 258.400 | \$19,475.61 | -258.400 | -\$19,475.61 | 0.000 | \$0.00 |
| Share # 2 | 0.000 | \$0.00 | 0.000 | \$0.00 | 0.000 | \$0.00 |

| | | | | | | | | | |
|----------------------------------|----------|----|-------------|---------|--------------|----------|---------------|---------|--------------|
| 0290 | 608.0101 | CY | \$1,055.090 | 524.400 | \$553,289.20 | -400.000 | -\$422,036.00 | 124.400 | \$131,253.20 |
| CONCRETE SIDEWALKS AND DRIVEWAYS | | | | | | | | | |

Reason: This decrease to the contract quantity is the result of this item being replaced with stamped colored concrete throughout the historical district as required by the City of Newburgh. The remaining quantity exceeds the anticipated amount required to complete work on the project and will be finalized in a future Change Order. Furthermore, this

| Line Number | Item ID | Unit | Unit Price | Current | | Change | | Revised | |
|-------------|---------|------|------------|----------|--------|----------|--------|----------|--------|
| | | | | Quantity | Amount | Quantity | Amount | Quantity | Amount |

decrease results in a Major Item underrun beyond the threshold for renegotiation, however the contractor has agreed to accept the original bid price for the remaining work, per the attached concurrence letter.

| Funding Details | | | | | | | |
|-----------------|---------|--------------|----------|---------------|---------|--------------|--|
| Share # 1 | 524.400 | \$553,289.20 | -400.000 | -\$422,036.00 | 124.400 | \$131,253.20 | |
| Share # 2 | 0.000 | \$0.00 | 0.000 | \$0.00 | 0.000 | \$0.00 | |

| | | | | | | | | | |
|------|--------------|----|-------------|--------|--------------|---------|---------------|--------|-------------|
| 0300 | 608.01050109 | EA | \$6,832.980 | 44.080 | \$301,197.76 | -31.080 | -\$212,369.02 | 13.000 | \$88,828.74 |
|------|--------------|----|-------------|--------|--------------|---------|---------------|--------|-------------|

CURB RAMP CONFIGURATION TYPE 1

Reason: This decrease to the contract quantity is the result of revising the curb ramps in the historic district of Newburgh to include colored concrete as per the requirements of the City of Newburgh. Furthermore, this decrease results in a Major Item underrun beyond the threshold for renegotiation, however the contractor has agreed to accept the original bid price for the remaining work, per the attached concurrence letter.

| Funding Details | | | | | | | |
|-----------------|--------|--------------|---------|---------------|--------|-------------|--|
| Share # 1 | 44.080 | \$301,197.76 | -31.080 | -\$212,369.02 | 13.000 | \$88,828.74 | |
| Share # 2 | 0.000 | \$0.00 | 0.000 | \$0.00 | 0.000 | \$0.00 | |

| | | | | | | | | | |
|------|--------------|----|--------------|-------|-------------|--------|--------------|-------|--------|
| 0310 | 608.01050909 | EA | \$12,158.690 | 1.520 | \$18,481.21 | -1.520 | -\$18,481.21 | 0.000 | \$0.00 |
|------|--------------|----|--------------|-------|-------------|--------|--------------|-------|--------|

CURB RAMP CONFIGURATION TYPE 9

Reason: This decrease to the contract quantity is the result of revising the curb ramps in the historic district of Newburgh to include colored concrete as per the requirements of the City of Newburgh.

| Funding Details | | | | | | | |
|-----------------|-------|-------------|--------|--------------|-------|--------|--|
| Share # 1 | 1.520 | \$18,481.21 | -1.520 | -\$18,481.21 | 0.000 | \$0.00 | |
| Share # 2 | 0.000 | \$0.00 | 0.000 | \$0.00 | 0.000 | \$0.00 | |

| Line Number | Item ID | Unit | Unit Price | Current | | Change | | Revised | |
|-------------|--------------|------|-------------|----------|-------------|----------|--------------|----------|--------|
| | | | | Quantity | Amount | Quantity | Amount | Quantity | Amount |
| 0320 | 608.01051109 | EA | \$6,732.500 | 1.520 | \$10,233.40 | -1.520 | -\$10,233.40 | 0.000 | \$0.00 |

CURB RAMP CONFIGURATION TYPE 11

Reason: This decrease to the contract quantity is the result of revising the curb ramps in the historic district of Newburgh to include colored concrete as per the requirements of the City of Newburgh.

| Funding Details | | | | | | | | | |
|-----------------|-----------|--|--|-------|-------------|--------|--------------|-------|--------|
| | Share # 1 | | | 1.520 | \$10,233.40 | -1.520 | -\$10,233.40 | 0.000 | \$0.00 |
| | Share # 2 | | | 0.000 | \$0.00 | 0.000 | \$0.00 | 0.000 | \$0.00 |

| | | | | | | | | | |
|------|--------------|----|-----------|---------|-------------|----------|--------------|-------|--------|
| 0350 | 608.13000039 | SY | \$180.870 | 297.920 | \$53,884.79 | -297.920 | -\$53,884.79 | 0.000 | \$0.00 |
|------|--------------|----|-----------|---------|-------------|----------|--------------|-------|--------|

PRECAST CONCRETE PERMEABLE PAVERS FOR SIDEWALKS, DRIVEWAYS AND BICYCLE PATHS

Reason: This decrease to the contract quantity is due to the elimination of this work which is being revised to stamped concrete.

| Funding Details | | | | | | | | | |
|-----------------|-----------|--|--|---------|-------------|----------|--------------|-------|--------|
| | Share # 1 | | | 297.920 | \$53,884.79 | -297.920 | -\$53,884.79 | 0.000 | \$0.00 |
| | Share # 2 | | | 0.000 | \$0.00 | 0.000 | \$0.00 | 0.000 | \$0.00 |

| | | | | | | | | | |
|------|--------------|----|----------|---------|-------------|----------|--------------|-------|--------|
| 0380 | 609.02160011 | LF | \$95.470 | 167.200 | \$15,962.58 | -167.200 | -\$15,962.58 | 0.000 | \$0.00 |
|------|--------------|----|----------|---------|-------------|----------|--------------|-------|--------|

STONE CURB (BLUESTONE)

Reason: This decrease to the contract quantity is the result of the elimination of this work from the contract.

| Funding Details | | | | | | | | | |
|-----------------|-----------|--|--|---------|-------------|----------|--------------|-------|--------|
| | Share # 1 | | | 167.200 | \$15,962.58 | -167.200 | -\$15,962.58 | 0.000 | \$0.00 |
| | Share # 2 | | | 0.000 | \$0.00 | 0.000 | \$0.00 | 0.000 | \$0.00 |

| Line Number | Item ID | Unit | Unit Price | Current | | Change | | Revised | |
|---------------------|-------------|------|------------|----------|------------|----------|-------------|----------|--------|
| | | | | Quantity | Amount | Quantity | Amount | Quantity | Amount |
| 0400 | 610.1400011 | CY | \$150.730 | 38.000 | \$5,727.74 | -38.000 | -\$5,727.74 | 0.000 | \$0.00 |
| STRUCTURAL SOIL MIX | | | | | | | | | |

Reason: This decrease to the contract quantity is due to the elimination of this item from the contract.

| Funding Details | | | | | | | | | |
|---|------------|----|-------------|--------|------------|---------|-------------|-------|------------|
| | Share # 1 | | | 38.000 | \$5,727.74 | -38.000 | -\$5,727.74 | 0.000 | \$0.00 |
| | Share # 2 | | | 0.000 | \$0.00 | 0.000 | \$0.00 | 0.000 | \$0.00 |
| 0430 | 614.060204 | EA | \$2,512.130 | 1.520 | \$3,818.44 | -0.520 | -\$1,306.31 | 1.000 | \$2,512.13 |
| TREE REMOVAL OVER 6 INCHES TO 12 INCHES DIAMETER BREAST HEIGHT - STUMPS GRUBBED | | | | | | | | | |

Reason: This decrease to the contract quantity is the result of the elimination of a portion of this work from the contract.

| Funding Details | | | | | | | | | |
|--|------------|----|---------|------------|-------------|-------------|--------------|-------|------------|
| | Share # 1 | | | 1.520 | \$3,818.44 | -0.520 | -\$1,306.31 | 1.000 | \$2,512.13 |
| | Share # 2 | | | 0.000 | \$0.00 | 0.000 | \$0.00 | 0.000 | \$0.00 |
| 0460 | 619.080101 | LF | \$4.520 | 14,820.000 | \$66,986.40 | -14,820.000 | -\$66,986.40 | 0.000 | \$0.00 |
| REMOVE PAVEMENT MARKING STRIPES, TRAFFIC PAINT | | | | | | | | | |

Reason: This decrease to the contract quantity is due to the elimination of this item from the contract.

| Funding Details | | | | | | | | | |
|-----------------|-----------|--|--|------------|-------------|-------------|--------------|-------|--------|
| | Share # 1 | | | 14,820.000 | \$66,986.40 | -14,820.000 | -\$66,986.40 | 0.000 | \$0.00 |
| | Share # 2 | | | 0.000 | \$0.00 | 0.000 | \$0.00 | 0.000 | \$0.00 |

| Line Number | Item ID | Unit | Unit Price | Current | | Change | | Revised | |
|-------------|---------|------|------------|----------|--------|----------|--------|----------|--------|
| | | | | Quantity | Amount | Quantity | Amount | Quantity | Amount |

| | | | | | | | | | |
|------|--------------|----|-------------|-------|------------|--------|-------------|-------|--------|
| 0540 | 634.06010007 | EA | \$1,004.850 | 8.360 | \$8,400.55 | -8.360 | -\$8,400.55 | 0.000 | \$0.00 |
|------|--------------|----|-------------|-------|------------|--------|-------------|-------|--------|

RELOCATE PARKING METER

Reason: This decrease to the contract quantity is due to the elimination of this item from the contract.

| Funding Details | | | | | | | | |
|-----------------|-------|------------|--------|-------------|-------|--------|--|--|
| Share # 1 | 8.360 | \$8,400.55 | -8.360 | -\$8,400.55 | 0.000 | \$0.00 | | |
| Share # 2 | 0.000 | \$0.00 | 0.000 | \$0.00 | 0.000 | \$0.00 | | |

| | | | | | | | | | |
|------|--------------|----|-------------|-------|-------------|--------|--------------|-------|--------|
| 0550 | 634.06070008 | EA | \$9,546.080 | 4.560 | \$43,530.12 | -4.560 | -\$43,530.12 | 0.000 | \$0.00 |
|------|--------------|----|-------------|-------|-------------|--------|--------------|-------|--------|

DOUBLE MANUAL VANDAL - RESISTANT PARKING METERS, WITH A SINGLE COLLECTION BOX

Reason: This decrease to the contract quantity is due to the elimination of this item. Prior to construction the City of Newburgh installed a parking paystation system, thereby eliminating the need for any meters.

| Funding Details | | | | | | | | |
|-----------------|-------|-------------|--------|--------------|-------|--------|--|--|
| Share # 1 | 4.560 | \$43,530.12 | -4.560 | -\$43,530.12 | 0.000 | \$0.00 | | |
| Share # 2 | 0.000 | \$0.00 | 0.000 | \$0.00 | 0.000 | \$0.00 | | |

| | | | | | | | | | |
|------|--------------|----|-------------|-------|-------------|--------|-------------|-------|-------------|
| 0610 | 655.05020008 | EA | \$4,521.830 | 8.360 | \$37,802.50 | -1.000 | -\$4,521.83 | 7.360 | \$33,280.67 |
|------|--------------|----|-------------|-------|-------------|--------|-------------|-------|-------------|

WATERTIGHT SANITARY MANHOLE FRAMES AND COVERS (CASTINGS)

Reason: This decrease to the contract quantity is the result of the elimination of SS-6 from the contract.

| Funding Details | | | | | | | | |
|-----------------|-------|-------------|--------|-------------|-------|-------------|--|--|
| Share # 1 | 8.360 | \$37,802.50 | -1.000 | -\$4,521.83 | 7.360 | \$33,280.67 | | |
| Share # 2 | 0.000 | \$0.00 | 0.000 | \$0.00 | 0.000 | \$0.00 | | |

| Line Number | Item ID | Unit | Unit Price | Current | | Change | | Revised | |
|-------------|---------|------|------------|----------|--------|----------|--------|----------|--------|
| | | | | Quantity | Amount | Quantity | Amount | Quantity | Amount |

| | | | | | | | | | |
|------|--------|----|---------|------------|--------------|-------------|---------------|-------|--------|
| 1080 | 685.11 | LF | \$5.090 | 19,790.400 | \$100,733.14 | -19,790.400 | -\$100,733.14 | 0.000 | \$0.00 |
|------|--------|----|---------|------------|--------------|-------------|---------------|-------|--------|

WHITE EPOXY REFLECTORIZED PAVEMENT STRIPES - 20 MILS

Reason: This decrease to the contract quantity is due to the elimination of this item from the contract.

Funding Details

| | | | | | | |
|-----------|------------|--------------|-------------|---------------|-------|--------|
| Share # 1 | 19,790.400 | \$100,733.14 | -19,790.400 | -\$100,733.14 | 0.000 | \$0.00 |
| Share # 2 | 0.000 | \$0.00 | 0.000 | \$0.00 | 0.000 | \$0.00 |

| | | | | | | | | | |
|------|--------|----|---------|---------|------------|----------|-------------|-------|--------|
| 1090 | 685.12 | LF | \$5.090 | 638.400 | \$3,249.46 | -638.400 | -\$3,249.46 | 0.000 | \$0.00 |
|------|--------|----|---------|---------|------------|----------|-------------|-------|--------|

YELLOW EPOXY REFLECTORIZED PAVEMENT STRIPES - 20 MILS

Reason: This decrease to the contract quantity is due to the elimination of this item from the contract.

Funding Details

| | | | | | | |
|-----------|---------|------------|----------|-------------|-------|--------|
| Share # 1 | 638.400 | \$3,249.46 | -638.400 | -\$3,249.46 | 0.000 | \$0.00 |
| Share # 2 | 0.000 | \$0.00 | 0.000 | \$0.00 | 0.000 | \$0.00 |

| | | | | | | | | | |
|------|-------------|----|---------|------------|-------------|-------------|--------------|-------|--------|
| 1100 | 691.0400002 | DC | \$1.000 | 38,760.000 | \$38,760.00 | -38,760.000 | -\$38,760.00 | 0.000 | \$0.00 |
|------|-------------|----|---------|------------|-------------|-------------|--------------|-------|--------|

TRAINING REQUIREMENTS

Reason: This decrease to the contract quantity is due to the elimination of this item, which was requested by the contractor and agreed to by the NYSDOT Region LPU.

Funding Details

| | | | | | | |
|-----------|------------|-------------|-------------|--------------|-------|--------|
| Share # 1 | 38,760.000 | \$38,760.00 | -38,760.000 | -\$38,760.00 | 0.000 | \$0.00 |
| Share # 2 | 0.000 | \$0.00 | 0.000 | \$0.00 | 0.000 | \$0.00 |

| Line Number | Item ID | Unit | Unit Price | Current | | Change | | Revised | |
|-------------|---------|------|------------|----------|--------|----------|--------|----------|--------|
| | | | | Quantity | Amount | Quantity | Amount | Quantity | Amount |

Section: 2 - Share #2

| | | | | | | | | | |
|------|--------|----|----------|---------|------------|----------|-------------|-------|--------|
| 1220 | 207.22 | SY | \$18.090 | 127.200 | \$2,301.05 | -127.200 | -\$2,301.05 | 0.000 | \$0.00 |
|------|--------|----|----------|---------|------------|----------|-------------|-------|--------|

GEOTEXTILE DRAINAGE

Reason: This decrease to the contract quantity is due to the elimination of this item from the contract.

| Funding Details | | | | | | | | | |
|-----------------|-----------|--|--|---------|------------|----------|-------------|-------|--------|
| | Share # 1 | | | 0.000 | \$0.00 | 0.000 | \$0.00 | 0.000 | \$0.00 |
| | Share # 2 | | | 127.200 | \$2,301.05 | -127.200 | -\$2,301.05 | 0.000 | \$0.00 |

| | | | | | | | | | |
|------|-------|----|----------|--------|------------|---------|-------------|-------|--------|
| 1320 | 490.3 | SY | \$75.370 | 81.600 | \$6,150.19 | -81.600 | -\$6,150.19 | 0.000 | \$0.00 |
|------|-------|----|----------|--------|------------|---------|-------------|-------|--------|

MISCELLANEOUS COLD MILLING OF BITUMINOUS CONCRETE

Reason: This decrease to the contract quantity is the result of the elimination of this work from the contract.

| Funding Details | | | | | | | | | |
|-----------------|-----------|--|--|--------|------------|---------|-------------|-------|--------|
| | Share # 1 | | | 0.000 | \$0.00 | 0.000 | \$0.00 | 0.000 | \$0.00 |
| | Share # 2 | | | 81.600 | \$6,150.19 | -81.600 | -\$6,150.19 | 0.000 | \$0.00 |

| | | | | | | | | | |
|------|----------|----|-------------|---------|--------------|----------|---------------|--------|-------------|
| 1430 | 608.0101 | CY | \$1,055.090 | 165.600 | \$174,722.90 | -135.000 | -\$142,437.15 | 30.600 | \$32,285.75 |
|------|----------|----|-------------|---------|--------------|----------|---------------|--------|-------------|

CONCRETE SIDEWALKS AND DRIVEWAYS

Reason: This decrease to the contract quantity is the result of this item being replaced with stamped colored concrete throughout the historical district as required by the City of Newburgh. The remaining quantity exceeds the anticipated amount required to complete work on the project and will be finalized in a future Change Order.

| Funding Details | | | | | | | | | |
|-----------------|-----------|--|--|-------|--------|-------|--------|-------|--------|
| | Share # 1 | | | 0.000 | \$0.00 | 0.000 | \$0.00 | 0.000 | \$0.00 |

| Line Number | Item ID | Unit | Unit Price | Current | | Change | | Revised | |
|-------------|---------|------|------------|----------|--------|----------|--------|----------|--------|
| | | | | Quantity | Amount | Quantity | Amount | Quantity | Amount |

| | | | | | | | | | |
|------|--------------|----|-------------|---------|--------------|----------|---------------|--------|-------------|
| | | | Share # 2 | 165.600 | \$174,722.90 | -135.000 | -\$142,437.15 | 30.600 | \$32,285.75 |
| 1440 | 608.01050109 | EA | \$6,832.980 | 13.920 | \$95,115.08 | -13.920 | -\$95,115.08 | 0.000 | \$0.00 |

CURB RAMP CONFIGURATION TYPE 1

Reason: This decrease to the contract quantity is the result of revising the curb ramps in the historic district of Newburgh to include colored concrete as per the requirements of the City of Newburgh.

Funding Details

| | | | | | | | | | |
|------|--------------|----|--------------|--------|-------------|---------|--------------|-------|--------|
| | | | Share # 1 | 0.000 | \$0.00 | 0.000 | \$0.00 | 0.000 | \$0.00 |
| | | | Share # 2 | 13.920 | \$95,115.08 | -13.920 | -\$95,115.08 | 0.000 | \$0.00 |
| 1450 | 608.01050909 | EA | \$12,158.690 | 0.480 | \$5,836.17 | -0.480 | -\$5,836.17 | 0.000 | \$0.00 |

CURB RAMP CONFIGURATION TYPE 9

Reason: This decrease to the contract quantity is the result of revising the curb ramps in the historic district of Newburgh to include colored concrete as per the requirements of the City of Newburgh.

Funding Details

| | | | | | | | | | |
|------|--------------|----|-------------|-------|------------|--------|-------------|-------|--------|
| | | | Share # 1 | 0.000 | \$0.00 | 0.000 | \$0.00 | 0.000 | \$0.00 |
| | | | Share # 2 | 0.480 | \$5,836.17 | -0.480 | -\$5,836.17 | 0.000 | \$0.00 |
| 1460 | 608.01051109 | EA | \$6,732.500 | 0.480 | \$3,231.60 | -0.480 | -\$3,231.60 | 0.000 | \$0.00 |

CURB RAMP CONFIGURATION TYPE 11

Reason: This decrease to the contract quantity is the result of revising the curb ramps in the historic district of Newburgh to include colored concrete as per the requirements of the City of Newburgh.

| Line Number | Item ID | Unit | Unit Price | Current | | Change | | Revised | |
|-------------|---------|------|------------|----------|--------|----------|--------|----------|--------|
| | | | | Quantity | Amount | Quantity | Amount | Quantity | Amount |

Funding Details

| | | | | | | | | | | |
|------|--------------|----|-----------|-----------|-------------|------------|--------------|-------------|--------|--------|
| | | | | Share # 1 | 0.000 | \$0.00 | 0.000 | \$0.00 | 0.000 | \$0.00 |
| | | | | Share # 2 | 0.480 | \$3,231.60 | -0.480 | -\$3,231.60 | 0.000 | \$0.00 |
| 1490 | 608.13000039 | SY | \$180.870 | 94.080 | \$17,016.25 | -94.080 | -\$17,016.25 | 0.000 | \$0.00 | |

PRECAST CONCRETE PERMEABLE PAVERS FOR SIDEWALKS, DRIVEWAYS AND BICYCLE PATHS

Reason: This decrease to the contract quantity is due to the elimination of this work which is being revised to stamped concrete.

Funding Details

| | | | | | | | | | | |
|------|--------------|----|----------|-----------|------------|-------------|-------------|--------------|--------|--------|
| | | | | Share # 1 | 0.000 | \$0.00 | 0.000 | \$0.00 | 0.000 | \$0.00 |
| | | | | Share # 2 | 94.080 | \$17,016.25 | -94.080 | -\$17,016.25 | 0.000 | \$0.00 |
| 1520 | 609.02160011 | LF | \$95.470 | 52.800 | \$5,040.82 | -52.800 | -\$5,040.82 | 0.000 | \$0.00 | |

STONE CURB (BLUESTONE)

Reason: This decrease to the contract quantity is due to the elimination of this item from the contract.

Funding Details

| | | | | | | | | | | |
|------|--------------|----|-----------|-----------|------------|------------|-------------|-------------|--------|--------|
| | | | | Share # 1 | 0.000 | \$0.00 | 0.000 | \$0.00 | 0.000 | \$0.00 |
| | | | | Share # 2 | 52.800 | \$5,040.82 | -52.800 | -\$5,040.82 | 0.000 | \$0.00 |
| 1540 | 610.14000011 | CY | \$150.730 | 12.000 | \$1,808.76 | -12.000 | -\$1,808.76 | 0.000 | \$0.00 | |

STRUCTURAL SOIL MIX

Reason: This decrease to the contract quantity is due to the elimination of this item from the contract.

| Line Number | Item ID | Unit | Unit Price | Current | | Change | | Revised | |
|-------------|---------|------|------------|----------|--------|----------|--------|----------|--------|
| | | | | Quantity | Amount | Quantity | Amount | Quantity | Amount |

Funding Details

| | | | | | | | | | | |
|------|------------|----|-------------|-----------|------------|------------|-------------|-------------|--------|--------|
| | | | | Share # 1 | 0.000 | \$0.00 | 0.000 | \$0.00 | 0.000 | \$0.00 |
| | | | | Share # 2 | 12.000 | \$1,808.76 | -12.000 | -\$1,808.76 | 0.000 | \$0.00 |
| 1570 | 614.060204 | EA | \$2,512.130 | 0.480 | \$1,205.82 | -0.480 | -\$1,205.82 | 0.000 | \$0.00 | |

TREE REMOVAL OVER 6 INCHES TO 12 INCHES DIAMETER BREAST HEIGHT - STUMPS GRUBBED

Reason: This decrease to the contract quantity is due to the elimination of this item from the contract.

Funding Details

| | | | | | | | | | | |
|------|------------|----|---------|-----------|-------------|------------|--------------|-------------|--------|--------|
| | | | | Share # 1 | 0.000 | \$0.00 | 0.000 | \$0.00 | 0.000 | \$0.00 |
| | | | | Share # 2 | 0.480 | \$1,205.82 | -0.480 | -\$1,205.82 | 0.000 | \$0.00 |
| 1600 | 619.080101 | LF | \$4.520 | 4,680.000 | \$21,153.60 | -4,680.000 | -\$21,153.60 | 0.000 | \$0.00 | |

REMOVE PAVEMENT MARKING STRIPES, TRAFFIC PAINT

Reason: This decrease to the contract quantity is due to the elimination of this item from the contract.

Funding Details

| | | | | | | | | | | |
|------|--------------|----|-------------|-----------|------------|-------------|------------|--------------|------------|--------|
| | | | | Share # 1 | 0.000 | \$0.00 | 0.000 | \$0.00 | 0.000 | \$0.00 |
| | | | | Share # 2 | 4,680.000 | \$21,153.60 | -4,680.000 | -\$21,153.60 | 0.000 | \$0.00 |
| 1660 | 625.09010015 | LS | \$7,300.000 | 1.000 | \$7,300.00 | 0.000 | \$0.70 | 1.000 | \$7,300.70 | |

SUBSURFACE SURVEY

Reason: This increase to the LS Bid Price is being made to correct an entry error during the original set up of Appia. The Share 2 amount was inadvertently entered as \$7,300.00 instead of \$7,300.70. Note: This revision will correct the item value.

| Line Number | Item ID | Unit | Unit Price | Current | | Change | | Revised | |
|-------------|---------|------|------------|----------|--------|----------|--------|----------|--------|
| | | | | Quantity | Amount | Quantity | Amount | Quantity | Amount |

Funding Details

| | | | | | | | | | | |
|------|--------------|----|-------------|-----------|------------|------------|-------------|--------|--------|------------|
| | | | | Share # 1 | 0.000 | \$0.00 | 0.000 | \$0.00 | 0.000 | \$0.00 |
| | | | | Share # 2 | 1.000 | \$7,300.00 | 0.000 | \$0.70 | 1.000 | \$7,300.70 |
| 1680 | 634.06010007 | EA | \$1,004.850 | 2.640 | \$2,652.80 | -2.640 | -\$2,652.80 | 0.000 | \$0.00 | |

RELOCATE PARKING METER

Reason: This decrease to the contract quantity is due to the elimination of this item from the contract.

Funding Details

| | | | | | | | | | | |
|------|--------------|----|-------------|-----------|-------------|------------|--------------|-------------|--------|--------|
| | | | | Share # 1 | 0.000 | \$0.00 | 0.000 | \$0.00 | 0.000 | \$0.00 |
| | | | | Share # 2 | 2.640 | \$2,652.80 | -2.640 | -\$2,652.80 | 0.000 | \$0.00 |
| 1690 | 634.06070008 | EA | \$9,546.080 | 1.440 | \$13,746.36 | -1.440 | -\$13,746.36 | 0.000 | \$0.00 | |

DOUBLE MANUAL VANDAL - RESISTANT PARKING METERS, WITH A SINGLE COLLECTION BOX

Reason: This decrease to the contract quantity is due to the elimination of this item. Prior to construction the City of Newburgh installed a parking paystation system, thereby eliminating the need for any meters

Funding Details

| | | | | | | | | | | |
|------|--------|----|---------|-----------|-------------|-------------|--------------|--------------|--------|--------|
| | | | | Share # 1 | 0.000 | \$0.00 | 0.000 | \$0.00 | 0.000 | \$0.00 |
| | | | | Share # 2 | 1.440 | \$13,746.36 | -1.440 | -\$13,746.36 | 0.000 | \$0.00 |
| 2220 | 685.11 | LF | \$5.090 | 6,249.600 | \$31,810.46 | -6,249.600 | -\$31,810.46 | 0.000 | \$0.00 | |

WHITE EPOXY REFLECTORIZED PAVEMENT STRIPES - 20 MILS

Reason: This decrease to the contract quantity is due to the elimination of this item from the contract.

| Line Number | Item ID | Unit | Unit Price | Current | | Change | | Revised | |
|-------------|---------|------|------------|----------|--------|----------|--------|----------|--------|
| | | | | Quantity | Amount | Quantity | Amount | Quantity | Amount |

| Funding Details | | | | | | | | | | |
|---|--------|----|---------|-----------|------------|-------------|-------------|--------------|--------|--------|
| | | | | Share # 1 | 0.000 | \$0.00 | 0.000 | \$0.00 | 0.000 | \$0.00 |
| | | | | Share # 2 | 6,249.600 | \$31,810.46 | -6,249.600 | -\$31,810.46 | 0.000 | \$0.00 |
| 2230 | 685.12 | LF | \$5.090 | 201.600 | \$1,026.14 | -201.600 | -\$1,026.14 | 0.000 | \$0.00 | |
| YELLOW EPOXY REFLECTORIZED PAVEMENT STRIPES - 20 MILS | | | | | | | | | | |

Reason: This decrease to the contract quantity is due to the elimination of this item from the contract.

| Funding Details | | | | | | | | | | |
|-----------------------|-------------|----|---------|------------|-------------|-------------|--------------|-------------|--------|--------|
| | | | | Share # 1 | 0.000 | \$0.00 | 0.000 | \$0.00 | 0.000 | \$0.00 |
| | | | | Share # 2 | 201.600 | \$1,026.14 | -201.600 | -\$1,026.14 | 0.000 | \$0.00 |
| 2240 | 691.0400002 | DC | \$1.000 | 12,240.000 | \$12,240.00 | -12,240.000 | -\$12,240.00 | 0.000 | \$0.00 | |
| TRAINING REQUIREMENTS | | | | | | | | | | |

Reason: This decrease to the contract quantity is due to the elimination of this item, which was requested by the contractor and agreed to by the NYSDOT Region LPU.

| Funding Details | | | | | | | | | | |
|-----------------|--|--|--|-----------|------------|----------------|-------------|-----------------|-------|--------------|
| | | | | Share # 1 | 0.000 | \$0.00 | 0.000 | \$0.00 | 0.000 | \$0.00 |
| | | | | Share # 2 | 12,240.000 | \$12,240.00 | -12,240.000 | -\$12,240.00 | 0.000 | \$0.00 |
| 34 items | | | | Totals | | \$1,691,177.55 | | -\$1,395,716.36 | | \$295,461.19 |

New Items

| Line Number | Item ID | Unit | Quantity | Unit Price | Extension |
|------------------------------|---------|------|----------|------------|-----------|
| Section: 1 - Share #1 | | | | | |

| | | | | | |
|------|---------|----|-------|-------------|-------------|
| 0072 | 206.05A | EA | 9.000 | \$8,416.080 | \$75,744.72 |
|------|---------|----|-------|-------------|-------------|

Test Pit Excavation (Changed Condition)

Reason: This NEW item is being added to the contract to facilitate payment to the contractor for the test pits required at proposed traffic signal poles per SS 680-3.10A. These test pits require deeper excavation and additional manpower to reach the full depth of the Type M Foundations, which are 12'-6" deep with a 4.0' diameter. This project has utilities at varying depths from 3.0' to 11.0' deep. The limited information from the utility owners was either inaccurate or incomplete at the time of design phase and could not be accurately reflected in the contract plans. All provisions of Standard Specification Section 206 shall apply, except that payment shall be made by this Agreed Price.

Funding Details

| | | | |
|-----------|-------|-------------|-------------|
| Share # 1 | 9.000 | \$8,416.080 | \$75,744.72 |
|-----------|-------|-------------|-------------|

| | | | | | |
|------|---------|----|---------|-------------|----------------|
| 0292 | 950.04A | CY | 520.000 | \$2,491.570 | \$1,295,616.40 |
|------|---------|----|---------|-------------|----------------|

Stamped Colored Concrete Sidewalk

Reason: This NEW item is being added to the contract to facilitate payment to the contractor for construction of stamped, colored concrete sidewalks within the historical district, per the requirements for the City of Newburgh. This work is replacing item 608.0101, which does not include the addition of color or imprinting. See the attached Agreed Price Package with Special Specification.

Funding Details

| | | | |
|-----------|---------|-------------|----------------|
| Share # 1 | 520.000 | \$2,491.570 | \$1,295,616.40 |
|-----------|---------|-------------|----------------|

| | | | | | |
|------|-----------|----|--------|-------------|--------------|
| 0305 | 950.0401A | EA | 34.000 | \$9,200.460 | \$312,815.64 |
|------|-----------|----|--------|-------------|--------------|

Curb Ramp Type 1 with Colored Concrete, Pro350 Sealer & Slip Resistant

Reason: This NEW item is being added to the contract to facilitate payment to the contractor for the revision to the Type 1 curb ramps including colored concrete as required in the historic district of Newburgh. See the attached Agreed Price Package with Special Specification. Payment shall be made by this Agreed Price.

| Line Number | Item ID | Unit | Quantity | Unit Price | Extension |
|-------------|---------|------|----------|------------|-----------|
|-------------|---------|------|----------|------------|-----------|

| | | | | |
|------------------------|--|--|--|--|
| Funding Details | | | | |
|------------------------|--|--|--|--|

| | | | | | |
|------|-----------|-----------|--------|--------------|--------------|
| | | Share # 1 | 34.000 | \$9,200.460 | \$312,815.64 |
| 0315 | 950.0402A | EA | 1.000 | \$10,633.720 | \$10,633.72 |

Curb Ramp Type 9 with Colored Concrete, Pro350 Sealer & Slip Resistant

Reason: This NEW item is being added to the contract to facilitate payment to the contractor for the revision to the Type 9 curb ramps including colored concrete as required in the historic district of Newburgh. See the attached Agreed Price Package with Special Specification. Payment shall be made by this Agreed Price.

| | | | | |
|------------------------|--|--|--|--|
| Funding Details | | | | |
|------------------------|--|--|--|--|

| | | | | | |
|------|-----------|-----------|-------|--------------|-------------|
| | | Share # 1 | 1.000 | \$10,633.720 | \$10,633.72 |
| 0325 | 950.0403A | EA | 2.000 | \$9,757.190 | \$19,514.38 |

Curb Ramp Type 11 with Colored Concrete, Pro350 Sealer & Slip Resistant

Reason: This NEW item is being added to the contract to facilitate payment to the contractor for the revision to the Type 11 curb ramps including colored concrete as required in the historic district of Newburgh. See the attached Agreed Price Package with Special Specification. Payment shall be made by this Agreed Price.

| | | | | |
|------------------------|--|--|--|--|
| Funding Details | | | | |
|------------------------|--|--|--|--|

| | | | | | |
|------|---------------|-----------|-------|-------------|-------------|
| | | Share # 1 | 2.000 | \$9,757.190 | \$19,514.38 |
| 0882 | 680.80324603A | EA | 4.000 | \$2,890.330 | \$11,561.32 |

Microcomputer Traffic Control Cabinet Base (Painted)

Reason: This NEW item is being added to the contract to facilitate payment to the contractor for the Microcomputer Traffic Control Cabinet Bases that need to be added to the contract due to a design revision changing from pole-mounted to ground-mounted cabinets. See the attached Agreed Price Package with Special Specification. Payment shall be made by this Agreed Price.

| | | | | |
|------------------------|--|--|--|--|
| Funding Details | | | | |
|------------------------|--|--|--|--|

| | | | | | |
|--|--|-----------|-------|-------------|-------------|
| | | Share # 1 | 4.000 | \$2,890.330 | \$11,561.32 |
|--|--|-----------|-------|-------------|-------------|

| Line Number | Item ID | Unit | Quantity | Unit Price | Extension |
|-------------|---------|------|----------|------------|-----------|
|-------------|---------|------|----------|------------|-----------|

Section: 2 - Share #2

| | | | | | |
|------|---------|----|-------|-------------|-------------|
| 1212 | 206.05A | EA | 4.000 | \$8,416.080 | \$33,664.32 |
|------|---------|----|-------|-------------|-------------|

Test Pit Excavation (Changed Condition)

Reason: This NEW item is being added to the contract to facilitate payment to the contractor for the test pits required at proposed traffic signal poles per SS 680-3.10A. These test pits require deeper excavation and additional manpower to reach the full depth of the Type M Foundations, which are 12'-6" deep with a 4.0' diameter. This project has utilities at varying depths from 3.0' to 11.0' deep. The limited information from the utility owners was either inaccurate or incomplete at the time of design phase and could not be accurately reflected in the contract plans. All provisions of Standard Specification Section 206 shall apply, except that payment shall be made by this Agreed Price.

| Funding Details | | | | | |
|-----------------|-----------|--|-------|-------------|-------------|
| | Share # 2 | | 4.000 | \$8,416.080 | \$33,664.32 |

| | | | | | |
|------|---------|----|---------|-------------|--------------|
| 1432 | 950.04A | CY | 200.000 | \$2,491.570 | \$498,314.00 |
|------|---------|----|---------|-------------|--------------|

Stamped Colored Concrete Sidewalk

Reason: This NEW item is being added to the contract to facilitate payment to the contractor for construction of stamped, colored concrete sidewalks within the historical district, per the requirements for the City of Newburgh. This work is replacing item 608.0101, which does not include the addition of color or imprinting. See the attached Agreed Price Package with Special Specification.

| Funding Details | | | | | |
|-----------------|-----------|--|---------|-------------|--------------|
| | Share # 2 | | 200.000 | \$2,491.570 | \$498,314.00 |

| | | | | | |
|------|-----------|----|--------|-------------|--------------|
| 1445 | 950.0401A | EA | 12.000 | \$9,200.460 | \$110,405.52 |
|------|-----------|----|--------|-------------|--------------|

Curb Ramp Type 1 with Colored Concrete, Pro350 Sealer & Slip Resistant

Reason: This NEW item is being added to the contract to facilitate payment to the contractor for the revision to the Type 1 curb ramps including colored concrete as required in the historic district of Newburgh. See the attached Agreed Price Package with Special Specification. Payment shall be made by this Agreed Price.

| Funding Details | | | | | |
|-----------------|-----------|--|--------|-------------|--------------|
| | Share # 2 | | 12.000 | \$9,200.460 | \$110,405.52 |

| Line Number | Item ID | Unit | Quantity | Unit Price | Extension |
|-------------|---------|------|----------|------------|-----------|
|-------------|---------|------|----------|------------|-----------|

| | | | | | |
|------|-----------|----|-------|--------------|-------------|
| 1455 | 950.0402A | EA | 1.000 | \$10,633.720 | \$10,633.72 |
|------|-----------|----|-------|--------------|-------------|

Curb Ramp Type 9 with Colored Concrete, Pro350 Sealer & Slip Resistant

Reason: This NEW item is being added to the contract to facilitate payment to the contractor for the revision to the Type 9 curb ramps including colored concrete as required in the historic district of Newburgh. See the attached Agreed Price Package with Special Specification. Payment shall be made by this Agreed Price.

| Funding Details | | | | |
|-----------------|--|--|--|--|
|-----------------|--|--|--|--|

| | | | |
|-----------|-------|--------------|-------------|
| Share # 2 | 1.000 | \$10,633.720 | \$10,633.72 |
|-----------|-------|--------------|-------------|

| | | | | | |
|------|---------------|----|-------|-------------|------------|
| 2022 | 680.80324603A | EA | 2.000 | \$2,890.330 | \$5,780.66 |
|------|---------------|----|-------|-------------|------------|

Microcomputer Traffic Control Cabinet Base (Painted)

Reason: This NEW item is being added to the contract to facilitate payment to the contractor for the Microcomputer Traffic Control Cabinet Bases that need to be added to the contract due to a design revision changing from pole-mounted to ground-mounted cabinets. See the attached Agreed Price Package with Special Specification. Payment shall be made by this Agreed Price.

| Funding Details | | | | |
|-----------------|--|--|--|--|
|-----------------|--|--|--|--|

| | | | |
|-----------|-------|-------------|------------|
| Share # 2 | 2.000 | \$2,890.330 | \$5,780.66 |
|-----------|-------|-------------|------------|

| | | | | |
|----------|-----------------------|--|--|--|
| 11 items | Total: \$2,384,684.40 | | | |
|----------|-----------------------|--|--|--|

Funding Summary

| Fund Package | Original Amount | Authorized Amount | Pending Change | Revised Amount |
|-----------------|-----------------|-------------------|----------------|----------------|
| Share # 1 | \$5,170,815.00 | \$5,170,815.00 | \$692,941.37 | \$5,863,756.37 |
| Share # 2 | \$1,632,888.26 | \$1,632,888.26 | \$296,026.67 | \$1,928,914.93 |
| 2 fund packages | \$6,803,703.26 | \$6,803,703.26 | \$988,968.04 | \$7,792,671.30 |

(Sponsor) Certificate of Recommended Order on Contract

PIN 8005.26 LD036472

City of Newburgh Purchase Order No.: 38718

PIN 8758.75 LD036469

Contractor Name: Verde Electric Maintenance Corporation

Change Order No. 01

I, Arlisa McGrath, RE, hereby certify that I am the officially designated Resident Engineer of the subject project, that the adjustments here within and the material incorporated under the subject contract as stated in the Change Order No. 01 are necessary, and to the best of my knowledge and belief, the said information is correct and in strict compliance with the terms of the said contract.

I further certify that the records from which this order on contract was developed and any other record required by stature, rule or regulation of the New York State Department of Transportation or the Federal Government or prescribed in the contract have been established and will be filed in the Consultant's Office, in accordance with the terms of the contract.

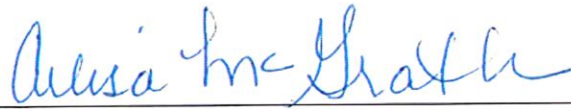

4/27/26

Arlisa McGrath, WSP USA Engineering, Resident Engineer

Date

Jason Morris, PE - Interim City Manager,
Commissioner of Public Works and City Engineer

Date

Change Order Details:

PINS 8005.26 & 8758.75 BROADWAY PTS

04/27/2026

Page 18 of 18

Page 63 of 397



WSP USA
500 Summit Lake Drive
Suite 450
Valhalla, NY 10595

Tel: 914 747 1120
Fax: 914 747 1956

wsp.com

April 27, 2026

City of Newburgh
83 Broadway
Newburgh, NY 11550

Attn. Mr. Chad M. Wade, R.L.A. Superintendent of Public Works
City of Newburgh Engineer, Sponsor

Re: *Project: PIN No. 8005.26 and 8758.75 Broadway Pedestrian and Traffic Signal Improvements
City of Newburgh, Orange County, New York
Change Order 001 w/Verde Construction*

Dear Mr. Wade

WSP recommends acceptance of Change Order 001 with Verde Construction for a net increase to the contract of \$988,968.04 for additional work including stamped colored concrete, colored curb ramps, ground mounted traffic signal cabinet bases and additional work related to utility conflicts. The additional project costs are being offset by project savings through the reduction in unit items, and from additional grant funds secured by the City from the Orange County Transportation Council. The additional costs associated with this change order will result in a revised contract amount of \$7,792,671.30.

Please find attached the following:

1. CONR 104 – Authorization of Extra Work
2. Appia Change Order 001 Details
3. CO 001 Analysis Sheet
4. Verde Agreed Price Packages

Very truly yours,
WSP USA Inc.

Arlisa McGrath, Resident Engineer

cc: Peter S. Mancuso, PE, PTOE, WSP
File: Verde Electric CO 001



WSP - Valhalla

Change Order Details

PINS 8005.26 & 8758.75 BROADWAY PTS

| | |
|----------------------------------|--|
| Description | CITY OF NEWBURGH PINS 8005.26 & 8758.75 BROADWAY PEDESTRIAN AND TRAFFIC SIGNAL IMPROVEMENTS |
| Prime Contractor | Verde Electric |
| Change Order | 1 |
| Status | Pending |
| Date Created | 06/18/2025 |
| Type | Added work to contract |
| Summary | New Items |
| Change Order Description | This Change Order is being created to add new item for test pits at proposed Traffic Signal Foundations due to existing underground utility conflicts unknown at time of design as well as a new item for Microcomputer Traffic Control Cabinet Bases due to a design change to install the Traffic Signal Cabinets on the ground in lieu of on the Traffic Signal Poles and a new item for changing curb ramps to include colored concrete at locations within the historical district of Newburgh. |
| Awarded Project Amount | \$6,803,703.26 |
| Authorized Project Amount | \$6,803,703.26 |
| Change Order Amount | \$988,968.04 |
| Revised Project Amount | \$7,792,671.30 |

Increases/Decreases

| Line Number | Item ID | Unit | Unit Price | Current | | Change | | Revised | |
|-------------|---------|------|------------|----------|--------|----------|--------|----------|--------|
| | | | | Quantity | Amount | Quantity | Amount | Quantity | Amount |

Section: 1 - Share #1

| | | | | | | | | | |
|---------------------|--------|----|----------|---------|------------|----------|-------------|-------|--------|
| 0080 | 207.22 | SY | \$18.090 | 402.800 | \$7,286.65 | -402.800 | -\$7,286.65 | 0.000 | \$0.00 |
| GEOTEXTILE DRAINAGE | | | | | | | | | |

Reason: This decrease to the contract quantity is due to the elimination of this item from the contract.

Funding Details

| | | | | | | |
|-----------|---------|------------|----------|-------------|-------|--------|
| Share # 1 | 402.800 | \$7,286.65 | -402.800 | -\$7,286.65 | 0.000 | \$0.00 |
| Share # 2 | 0.000 | \$0.00 | 0.000 | \$0.00 | 0.000 | \$0.00 |

| | | | | | | | | | |
|---|-------|----|----------|---------|-------------|----------|--------------|-------|--------|
| 0180 | 490.3 | SY | \$75.370 | 258.400 | \$19,475.61 | -258.400 | -\$19,475.61 | 0.000 | \$0.00 |
| MISCELLANEOUS COLD MILLING OF BITUMINOUS CONCRETE | | | | | | | | | |

Reason: This decrease to the contract quantity is the result of the elimination of this work from the contract.

Funding Details

| | | | | | | |
|-----------|---------|-------------|----------|--------------|-------|--------|
| Share # 1 | 258.400 | \$19,475.61 | -258.400 | -\$19,475.61 | 0.000 | \$0.00 |
| Share # 2 | 0.000 | \$0.00 | 0.000 | \$0.00 | 0.000 | \$0.00 |

| | | | | | | | | | |
|----------------------------------|----------|----|-------------|---------|--------------|----------|---------------|---------|--------------|
| 0290 | 608.0101 | CY | \$1,055.090 | 524.400 | \$553,289.20 | -400.000 | -\$422,036.00 | 124.400 | \$131,253.20 |
| CONCRETE SIDEWALKS AND DRIVEWAYS | | | | | | | | | |

Reason: This decrease to the contract quantity is the result of this item being replaced with stamped colored concrete throughout the historical district as required by the City of Newburgh. The remaining quantity exceeds the anticipated amount required to complete work on the project and will be finalized in a future Change Order. Furthermore, this

| Line Number | Item ID | Unit | Unit Price | Current | | Change | | Revised | |
|-------------|---------|------|------------|----------|--------|----------|--------|----------|--------|
| | | | | Quantity | Amount | Quantity | Amount | Quantity | Amount |

decrease results in a Major Item underrun beyond the threshold for renegotiation, however the contractor has agreed to accept the original bid price for the remaining work, per the attached concurrence letter.

| Funding Details | | | | | | | |
|-----------------|---------|--------------|----------|---------------|---------|--------------|--|
| Share # 1 | 524.400 | \$553,289.20 | -400.000 | -\$422,036.00 | 124.400 | \$131,253.20 | |
| Share # 2 | 0.000 | \$0.00 | 0.000 | \$0.00 | 0.000 | \$0.00 | |

| | | | | | | | | | |
|------|--------------|----|-------------|--------|--------------|---------|---------------|--------|-------------|
| 0300 | 608.01050109 | EA | \$6,832.980 | 44.080 | \$301,197.76 | -31.080 | -\$212,369.02 | 13.000 | \$88,828.74 |
|------|--------------|----|-------------|--------|--------------|---------|---------------|--------|-------------|

CURB RAMP CONFIGURATION TYPE 1

Reason: This decrease to the contract quantity is the result of revising the curb ramps in the historic district of Newburgh to include colored concrete as per the requirements of the City of Newburgh. Furthermore, this decrease results in a Major Item underrun beyond the threshold for renegotiation, however the contractor has agreed to accept the original bid price for the remaining work, per the attached concurrence letter.

| Funding Details | | | | | | | |
|-----------------|--------|--------------|---------|---------------|--------|-------------|--|
| Share # 1 | 44.080 | \$301,197.76 | -31.080 | -\$212,369.02 | 13.000 | \$88,828.74 | |
| Share # 2 | 0.000 | \$0.00 | 0.000 | \$0.00 | 0.000 | \$0.00 | |

| | | | | | | | | | |
|------|--------------|----|--------------|-------|-------------|--------|--------------|-------|--------|
| 0310 | 608.01050909 | EA | \$12,158.690 | 1.520 | \$18,481.21 | -1.520 | -\$18,481.21 | 0.000 | \$0.00 |
|------|--------------|----|--------------|-------|-------------|--------|--------------|-------|--------|

CURB RAMP CONFIGURATION TYPE 9

Reason: This decrease to the contract quantity is the result of revising the curb ramps in the historic district of Newburgh to include colored concrete as per the requirements of the City of Newburgh.

| Funding Details | | | | | | | |
|-----------------|-------|-------------|--------|--------------|-------|--------|--|
| Share # 1 | 1.520 | \$18,481.21 | -1.520 | -\$18,481.21 | 0.000 | \$0.00 | |
| Share # 2 | 0.000 | \$0.00 | 0.000 | \$0.00 | 0.000 | \$0.00 | |

| Line Number | Item ID | Unit | Unit Price | Current | | Change | | Revised | |
|-------------|--------------|------|-------------|----------|-------------|----------|--------------|----------|--------|
| | | | | Quantity | Amount | Quantity | Amount | Quantity | Amount |
| 0320 | 608.01051109 | EA | \$6,732.500 | 1.520 | \$10,233.40 | -1.520 | -\$10,233.40 | 0.000 | \$0.00 |

CURB RAMP CONFIGURATION TYPE 11

Reason: This decrease to the contract quantity is the result of revising the curb ramps in the historic district of Newburgh to include colored concrete as per the requirements of the City of Newburgh.

| Funding Details | | | | | | | |
|-----------------|-------|-------------|--------|--------------|-------|--------|--|
| Share # 1 | 1.520 | \$10,233.40 | -1.520 | -\$10,233.40 | 0.000 | \$0.00 | |
| Share # 2 | 0.000 | \$0.00 | 0.000 | \$0.00 | 0.000 | \$0.00 | |

| | | | | | | | | | |
|------|--------------|----|-----------|---------|-------------|----------|--------------|-------|--------|
| 0350 | 608.13000039 | SY | \$180.870 | 297.920 | \$53,884.79 | -297.920 | -\$53,884.79 | 0.000 | \$0.00 |
|------|--------------|----|-----------|---------|-------------|----------|--------------|-------|--------|

PRECAST CONCRETE PERMEABLE PAVERS FOR SIDEWALKS, DRIVEWAYS AND BICYCLE PATHS

Reason: This decrease to the contract quantity is due to the elimination of this work which is being revised to stamped concrete.

| Funding Details | | | | | | | |
|-----------------|---------|-------------|----------|--------------|-------|--------|--|
| Share # 1 | 297.920 | \$53,884.79 | -297.920 | -\$53,884.79 | 0.000 | \$0.00 | |
| Share # 2 | 0.000 | \$0.00 | 0.000 | \$0.00 | 0.000 | \$0.00 | |

| | | | | | | | | | |
|------|--------------|----|----------|---------|-------------|----------|--------------|-------|--------|
| 0380 | 609.02160011 | LF | \$95.470 | 167.200 | \$15,962.58 | -167.200 | -\$15,962.58 | 0.000 | \$0.00 |
|------|--------------|----|----------|---------|-------------|----------|--------------|-------|--------|

STONE CURB (BLUESTONE)

Reason: This decrease to the contract quantity is the result of the elimination of this work from the contract.

| Funding Details | | | | | | | |
|-----------------|---------|-------------|----------|--------------|-------|--------|--|
| Share # 1 | 167.200 | \$15,962.58 | -167.200 | -\$15,962.58 | 0.000 | \$0.00 | |
| Share # 2 | 0.000 | \$0.00 | 0.000 | \$0.00 | 0.000 | \$0.00 | |

| Line Number | Item ID | Unit | Unit Price | Current | | Change | | Revised | |
|---------------------|-------------|------|------------|----------|------------|----------|-------------|----------|--------|
| | | | | Quantity | Amount | Quantity | Amount | Quantity | Amount |
| 0400 | 610.1400011 | CY | \$150.730 | 38.000 | \$5,727.74 | -38.000 | -\$5,727.74 | 0.000 | \$0.00 |
| STRUCTURAL SOIL MIX | | | | | | | | | |

Reason: This decrease to the contract quantity is due to the elimination of this item from the contract.

| Funding Details | | | | | | | | | |
|---|------------|----|-------------|--------|------------|---------|-------------|-------|------------|
| | Share # 1 | | | 38.000 | \$5,727.74 | -38.000 | -\$5,727.74 | 0.000 | \$0.00 |
| | Share # 2 | | | 0.000 | \$0.00 | 0.000 | \$0.00 | 0.000 | \$0.00 |
| 0430 | 614.060204 | EA | \$2,512.130 | 1.520 | \$3,818.44 | -0.520 | -\$1,306.31 | 1.000 | \$2,512.13 |
| TREE REMOVAL OVER 6 INCHES TO 12 INCHES DIAMETER BREAST HEIGHT - STUMPS GRUBBED | | | | | | | | | |

Reason: This decrease to the contract quantity is the result of the elimination of a portion of this work from the contract.

| Funding Details | | | | | | | | | |
|--|------------|----|---------|------------|-------------|-------------|--------------|-------|------------|
| | Share # 1 | | | 1.520 | \$3,818.44 | -0.520 | -\$1,306.31 | 1.000 | \$2,512.13 |
| | Share # 2 | | | 0.000 | \$0.00 | 0.000 | \$0.00 | 0.000 | \$0.00 |
| 0460 | 619.080101 | LF | \$4.520 | 14,820.000 | \$66,986.40 | -14,820.000 | -\$66,986.40 | 0.000 | \$0.00 |
| REMOVE PAVEMENT MARKING STRIPES, TRAFFIC PAINT | | | | | | | | | |

Reason: This decrease to the contract quantity is due to the elimination of this item from the contract.

| Funding Details | | | | | | | | | |
|-----------------|-----------|--|--|------------|-------------|-------------|--------------|-------|--------|
| | Share # 1 | | | 14,820.000 | \$66,986.40 | -14,820.000 | -\$66,986.40 | 0.000 | \$0.00 |
| | Share # 2 | | | 0.000 | \$0.00 | 0.000 | \$0.00 | 0.000 | \$0.00 |

| Line Number | Item ID | Unit | Unit Price | Current | | Change | | Revised | |
|-------------|---------|------|------------|----------|--------|----------|--------|----------|--------|
| | | | | Quantity | Amount | Quantity | Amount | Quantity | Amount |

| | | | | | | | | | |
|------|--------------|----|-------------|-------|------------|--------|-------------|-------|--------|
| 0540 | 634.06010007 | EA | \$1,004.850 | 8.360 | \$8,400.55 | -8.360 | -\$8,400.55 | 0.000 | \$0.00 |
|------|--------------|----|-------------|-------|------------|--------|-------------|-------|--------|

RELOCATE PARKING METER

Reason: This decrease to the contract quantity is due to the elimination of this item from the contract.

| Funding Details | | | | | | | | | |
|-----------------|-----------|--|--|-------|------------|--------|-------------|-------|--------|
| | Share # 1 | | | 8.360 | \$8,400.55 | -8.360 | -\$8,400.55 | 0.000 | \$0.00 |
| | Share # 2 | | | 0.000 | \$0.00 | 0.000 | \$0.00 | 0.000 | \$0.00 |

| | | | | | | | | | |
|------|--------------|----|-------------|-------|-------------|--------|--------------|-------|--------|
| 0550 | 634.06070008 | EA | \$9,546.080 | 4.560 | \$43,530.12 | -4.560 | -\$43,530.12 | 0.000 | \$0.00 |
|------|--------------|----|-------------|-------|-------------|--------|--------------|-------|--------|

DOUBLE MANUAL VANDAL - RESISTANT PARKING METERS, WITH A SINGLE COLLECTION BOX

Reason: This decrease to the contract quantity is due to the elimination of this item. Prior to construction the City of Newburgh installed a parking paystation system, thereby eliminating the need for any meters.

| Funding Details | | | | | | | | | |
|-----------------|-----------|--|--|-------|-------------|--------|--------------|-------|--------|
| | Share # 1 | | | 4.560 | \$43,530.12 | -4.560 | -\$43,530.12 | 0.000 | \$0.00 |
| | Share # 2 | | | 0.000 | \$0.00 | 0.000 | \$0.00 | 0.000 | \$0.00 |

| | | | | | | | | | |
|------|--------------|----|-------------|-------|-------------|--------|-------------|-------|-------------|
| 0610 | 655.05020008 | EA | \$4,521.830 | 8.360 | \$37,802.50 | -1.000 | -\$4,521.83 | 7.360 | \$33,280.67 |
|------|--------------|----|-------------|-------|-------------|--------|-------------|-------|-------------|

WATERTIGHT SANITARY MANHOLE FRAMES AND COVERS (CASTINGS)

Reason: This decrease to the contract quantity is the result of the elimination of SS-6 from the contract.

| Funding Details | | | | | | | | | |
|-----------------|-----------|--|--|-------|-------------|--------|-------------|-------|-------------|
| | Share # 1 | | | 8.360 | \$37,802.50 | -1.000 | -\$4,521.83 | 7.360 | \$33,280.67 |
| | Share # 2 | | | 0.000 | \$0.00 | 0.000 | \$0.00 | 0.000 | \$0.00 |

| Line Number | Item ID | Unit | Unit Price | Current | | Change | | Revised | |
|-------------|---------|------|------------|----------|--------|----------|--------|----------|--------|
| | | | | Quantity | Amount | Quantity | Amount | Quantity | Amount |

| | | | | | | | | | |
|------|--------|----|---------|------------|--------------|-------------|---------------|-------|--------|
| 1080 | 685.11 | LF | \$5.090 | 19,790.400 | \$100,733.14 | -19,790.400 | -\$100,733.14 | 0.000 | \$0.00 |
|------|--------|----|---------|------------|--------------|-------------|---------------|-------|--------|

WHITE EPOXY REFLECTORIZED PAVEMENT STRIPES - 20 MILS

Reason: This decrease to the contract quantity is due to the elimination of this item from the contract.

Funding Details

| | | | | | | |
|-----------|------------|--------------|-------------|---------------|-------|--------|
| Share # 1 | 19,790.400 | \$100,733.14 | -19,790.400 | -\$100,733.14 | 0.000 | \$0.00 |
| Share # 2 | 0.000 | \$0.00 | 0.000 | \$0.00 | 0.000 | \$0.00 |

| | | | | | | | | | |
|------|--------|----|---------|---------|------------|----------|-------------|-------|--------|
| 1090 | 685.12 | LF | \$5.090 | 638.400 | \$3,249.46 | -638.400 | -\$3,249.46 | 0.000 | \$0.00 |
|------|--------|----|---------|---------|------------|----------|-------------|-------|--------|

YELLOW EPOXY REFLECTORIZED PAVEMENT STRIPES - 20 MILS

Reason: This decrease to the contract quantity is due to the elimination of this item from the contract.

Funding Details

| | | | | | | |
|-----------|---------|------------|----------|-------------|-------|--------|
| Share # 1 | 638.400 | \$3,249.46 | -638.400 | -\$3,249.46 | 0.000 | \$0.00 |
| Share # 2 | 0.000 | \$0.00 | 0.000 | \$0.00 | 0.000 | \$0.00 |

| | | | | | | | | | |
|------|-------------|----|---------|------------|-------------|-------------|--------------|-------|--------|
| 1100 | 691.0400002 | DC | \$1.000 | 38,760.000 | \$38,760.00 | -38,760.000 | -\$38,760.00 | 0.000 | \$0.00 |
|------|-------------|----|---------|------------|-------------|-------------|--------------|-------|--------|

TRAINING REQUIREMENTS

Reason: This decrease to the contract quantity is due to the elimination of this item, which was requested by the contractor and agreed to by the NYSDOT Region LPU.

Funding Details

| | | | | | | |
|-----------|------------|-------------|-------------|--------------|-------|--------|
| Share # 1 | 38,760.000 | \$38,760.00 | -38,760.000 | -\$38,760.00 | 0.000 | \$0.00 |
| Share # 2 | 0.000 | \$0.00 | 0.000 | \$0.00 | 0.000 | \$0.00 |

| Line Number | Item ID | Unit | Unit Price | Current | | Change | | Revised | |
|-------------|---------|------|------------|----------|--------|----------|--------|----------|--------|
| | | | | Quantity | Amount | Quantity | Amount | Quantity | Amount |

Section: 2 - Share #2

| | | | | | | | | | |
|---------------------|--------|----|----------|---------|------------|----------|-------------|-------|--------|
| 1220 | 207.22 | SY | \$18.090 | 127.200 | \$2,301.05 | -127.200 | -\$2,301.05 | 0.000 | \$0.00 |
| GEOTEXTILE DRAINAGE | | | | | | | | | |

Reason: This decrease to the contract quantity is due to the elimination of this item from the contract.

| Funding Details | | | | | | | | | |
|-----------------|-----------|--|--|---------|------------|----------|-------------|-------|--------|
| | Share # 1 | | | 0.000 | \$0.00 | 0.000 | \$0.00 | 0.000 | \$0.00 |
| | Share # 2 | | | 127.200 | \$2,301.05 | -127.200 | -\$2,301.05 | 0.000 | \$0.00 |

| | | | | | | | | | |
|---|-------|----|----------|--------|------------|---------|-------------|-------|--------|
| 1320 | 490.3 | SY | \$75.370 | 81.600 | \$6,150.19 | -81.600 | -\$6,150.19 | 0.000 | \$0.00 |
| MISCELLANEOUS COLD MILLING OF BITUMINOUS CONCRETE | | | | | | | | | |

Reason: This decrease to the contract quantity is the result of the elimination of this work from the contract.

| Funding Details | | | | | | | | | |
|-----------------|-----------|--|--|--------|------------|---------|-------------|-------|--------|
| | Share # 1 | | | 0.000 | \$0.00 | 0.000 | \$0.00 | 0.000 | \$0.00 |
| | Share # 2 | | | 81.600 | \$6,150.19 | -81.600 | -\$6,150.19 | 0.000 | \$0.00 |

| | | | | | | | | | |
|----------------------------------|----------|----|-------------|---------|--------------|----------|---------------|--------|-------------|
| 1430 | 608.0101 | CY | \$1,055.090 | 165.600 | \$174,722.90 | -135.000 | -\$142,437.15 | 30.600 | \$32,285.75 |
| CONCRETE SIDEWALKS AND DRIVEWAYS | | | | | | | | | |

Reason: This decrease to the contract quantity is the result of this item being replaced with stamped colored concrete throughout the historical district as required by the City of Newburgh. The remaining quantity exceeds the anticipated amount required to complete work on the project and will be finalized in a future Change Order.

| Funding Details | | | | | | | | | |
|-----------------|-----------|--|--|-------|--------|-------|--------|-------|--------|
| | Share # 1 | | | 0.000 | \$0.00 | 0.000 | \$0.00 | 0.000 | \$0.00 |

| Line Number | Item ID | Unit | Unit Price | Current | | Change | | Revised | |
|-------------|---------|------|------------|----------|--------|----------|--------|----------|--------|
| | | | | Quantity | Amount | Quantity | Amount | Quantity | Amount |

| | | | | | | | | | |
|------|--------------|----|-------------|---------|--------------|----------|---------------|--------|-------------|
| | | | Share # 2 | 165.600 | \$174,722.90 | -135.000 | -\$142,437.15 | 30.600 | \$32,285.75 |
| 1440 | 608.01050109 | EA | \$6,832.980 | 13.920 | \$95,115.08 | -13.920 | -\$95,115.08 | 0.000 | \$0.00 |

CURB RAMP CONFIGURATION TYPE 1

Reason: This decrease to the contract quantity is the result of revising the curb ramps in the historic district of Newburgh to include colored concrete as per the requirements of the City of Newburgh.

Funding Details

| | | | | | | | | | |
|------|--------------|----|--------------|--------|-------------|---------|--------------|-------|--------|
| | | | Share # 1 | 0.000 | \$0.00 | 0.000 | \$0.00 | 0.000 | \$0.00 |
| | | | Share # 2 | 13.920 | \$95,115.08 | -13.920 | -\$95,115.08 | 0.000 | \$0.00 |
| 1450 | 608.01050909 | EA | \$12,158.690 | 0.480 | \$5,836.17 | -0.480 | -\$5,836.17 | 0.000 | \$0.00 |

CURB RAMP CONFIGURATION TYPE 9

Reason: This decrease to the contract quantity is the result of revising the curb ramps in the historic district of Newburgh to include colored concrete as per the requirements of the City of Newburgh.

Funding Details

| | | | | | | | | | |
|------|--------------|----|-------------|-------|------------|--------|-------------|-------|--------|
| | | | Share # 1 | 0.000 | \$0.00 | 0.000 | \$0.00 | 0.000 | \$0.00 |
| | | | Share # 2 | 0.480 | \$5,836.17 | -0.480 | -\$5,836.17 | 0.000 | \$0.00 |
| 1460 | 608.01051109 | EA | \$6,732.500 | 0.480 | \$3,231.60 | -0.480 | -\$3,231.60 | 0.000 | \$0.00 |

CURB RAMP CONFIGURATION TYPE 11

Reason: This decrease to the contract quantity is the result of revising the curb ramps in the historic district of Newburgh to include colored concrete as per the requirements of the City of Newburgh.

| Line Number | Item ID | Unit | Unit Price | Current | | Change | | Revised | |
|-------------|---------|------|------------|----------|--------|----------|--------|----------|--------|
| | | | | Quantity | Amount | Quantity | Amount | Quantity | Amount |

Funding Details

| | | | | | | | | | |
|------|--------------|----|-----------|--------|-------------|---------|--------------|-------|--------|
| | | | Share # 1 | 0.000 | \$0.00 | 0.000 | \$0.00 | 0.000 | \$0.00 |
| | | | Share # 2 | 0.480 | \$3,231.60 | -0.480 | -\$3,231.60 | 0.000 | \$0.00 |
| 1490 | 608.13000039 | SY | | 94.080 | \$17,016.25 | -94.080 | -\$17,016.25 | 0.000 | \$0.00 |

PRECAST CONCRETE PERMEABLE PAVERS FOR SIDEWALKS, DRIVEWAYS AND BICYCLE PATHS

Reason: This decrease to the contract quantity is due to the elimination of this work which is being revised to stamped concrete.

Funding Details

| | | | | | | | | | |
|------|--------------|----|-----------|--------|-------------|---------|--------------|-------|--------|
| | | | Share # 1 | 0.000 | \$0.00 | 0.000 | \$0.00 | 0.000 | \$0.00 |
| | | | Share # 2 | 94.080 | \$17,016.25 | -94.080 | -\$17,016.25 | 0.000 | \$0.00 |
| 1520 | 609.02160011 | LF | | 52.800 | \$5,040.82 | -52.800 | -\$5,040.82 | 0.000 | \$0.00 |

STONE CURB (BLUESTONE)

Reason: This decrease to the contract quantity is due to the elimination of this item from the contract.

Funding Details

| | | | | | | | | | |
|------|--------------|----|-----------|--------|------------|---------|-------------|-------|--------|
| | | | Share # 1 | 0.000 | \$0.00 | 0.000 | \$0.00 | 0.000 | \$0.00 |
| | | | Share # 2 | 52.800 | \$5,040.82 | -52.800 | -\$5,040.82 | 0.000 | \$0.00 |
| 1540 | 610.14000011 | CY | | 12.000 | \$1,808.76 | -12.000 | -\$1,808.76 | 0.000 | \$0.00 |

STRUCTURAL SOIL MIX

Reason: This decrease to the contract quantity is due to the elimination of this item from the contract.

| Line Number | Item ID | Unit | Unit Price | Current | | Change | | Revised | |
|-------------|---------|------|------------|----------|--------|----------|--------|----------|--------|
| | | | | Quantity | Amount | Quantity | Amount | Quantity | Amount |

Funding Details

| | | | | | | | | | | |
|------|------------|----|-------------|-----------|------------|------------|-------------|-------------|--------|--------|
| | | | | Share # 1 | 0.000 | \$0.00 | 0.000 | \$0.00 | 0.000 | \$0.00 |
| | | | | Share # 2 | 12.000 | \$1,808.76 | -12.000 | -\$1,808.76 | 0.000 | \$0.00 |
| 1570 | 614.060204 | EA | \$2,512.130 | 0.480 | \$1,205.82 | -0.480 | -\$1,205.82 | 0.000 | \$0.00 | |

TREE REMOVAL OVER 6 INCHES TO 12 INCHES DIAMETER BREAST HEIGHT - STUMPS GRUBBED

Reason: This decrease to the contract quantity is due to the elimination of this item from the contract.

Funding Details

| | | | | | | | | | | |
|------|------------|----|---------|-----------|-------------|------------|--------------|-------------|--------|--------|
| | | | | Share # 1 | 0.000 | \$0.00 | 0.000 | \$0.00 | 0.000 | \$0.00 |
| | | | | Share # 2 | 0.480 | \$1,205.82 | -0.480 | -\$1,205.82 | 0.000 | \$0.00 |
| 1600 | 619.080101 | LF | \$4.520 | 4,680.000 | \$21,153.60 | -4,680.000 | -\$21,153.60 | 0.000 | \$0.00 | |

REMOVE PAVEMENT MARKING STRIPES, TRAFFIC PAINT

Reason: This decrease to the contract quantity is due to the elimination of this item from the contract.

Funding Details

| | | | | | | | | | | |
|------|--------------|----|-------------|-----------|------------|-------------|------------|--------------|------------|--------|
| | | | | Share # 1 | 0.000 | \$0.00 | 0.000 | \$0.00 | 0.000 | \$0.00 |
| | | | | Share # 2 | 4,680.000 | \$21,153.60 | -4,680.000 | -\$21,153.60 | 0.000 | \$0.00 |
| 1660 | 625.09010015 | LS | \$7,300.000 | 1.000 | \$7,300.00 | 0.000 | \$0.70 | 1.000 | \$7,300.70 | |

SUBSURFACE SURVEY

Reason: This increase to the LS Bid Price is being made to correct an entry error during the original set up of Appia. The Share 2 amount was inadvertently entered as \$7,300.00 instead of \$7,300.70. Note: This revision will correct the item value.

| Line Number | Item ID | Unit | Unit Price | Current | | Change | | Revised | |
|-------------|---------|------|------------|----------|--------|----------|--------|----------|--------|
| | | | | Quantity | Amount | Quantity | Amount | Quantity | Amount |

Funding Details

| | | | | | | | | | | |
|------|--------------|----|-------------|-----------|------------|------------|-------------|--------|--------|------------|
| | | | | Share # 1 | 0.000 | \$0.00 | 0.000 | \$0.00 | 0.000 | \$0.00 |
| | | | | Share # 2 | 1.000 | \$7,300.00 | 0.000 | \$0.70 | 1.000 | \$7,300.70 |
| 1680 | 634.06010007 | EA | \$1,004.850 | 2.640 | \$2,652.80 | -2.640 | -\$2,652.80 | 0.000 | \$0.00 | |

RELOCATE PARKING METER

Reason: This decrease to the contract quantity is due to the elimination of this item from the contract.

Funding Details

| | | | | | | | | | | |
|------|--------------|----|-------------|-----------|-------------|------------|--------------|-------------|--------|--------|
| | | | | Share # 1 | 0.000 | \$0.00 | 0.000 | \$0.00 | 0.000 | \$0.00 |
| | | | | Share # 2 | 2.640 | \$2,652.80 | -2.640 | -\$2,652.80 | 0.000 | \$0.00 |
| 1690 | 634.06070008 | EA | \$9,546.080 | 1.440 | \$13,746.36 | -1.440 | -\$13,746.36 | 0.000 | \$0.00 | |

DOUBLE MANUAL VANDAL - RESISTANT PARKING METERS, WITH A SINGLE COLLECTION BOX

Reason: This decrease to the contract quantity is due to the elimination of this item. Prior to construction the City of Newburgh installed a parking paystation system, thereby eliminating the need for any meters

Funding Details

| | | | | | | | | | | |
|------|--------|----|---------|-----------|-------------|-------------|--------------|--------------|--------|--------|
| | | | | Share # 1 | 0.000 | \$0.00 | 0.000 | \$0.00 | 0.000 | \$0.00 |
| | | | | Share # 2 | 1.440 | \$13,746.36 | -1.440 | -\$13,746.36 | 0.000 | \$0.00 |
| 2220 | 685.11 | LF | \$5.090 | 6,249.600 | \$31,810.46 | -6,249.600 | -\$31,810.46 | 0.000 | \$0.00 | |

WHITE EPOXY REFLECTORIZED PAVEMENT STRIPES - 20 MILS

Reason: This decrease to the contract quantity is due to the elimination of this item from the contract.

| Line Number | Item ID | Unit | Unit Price | Current | | Change | | Revised | |
|-------------|---------|------|------------|----------|--------|----------|--------|----------|--------|
| | | | | Quantity | Amount | Quantity | Amount | Quantity | Amount |

| Funding Details | | | | | | | | | | |
|---|--------|----|---------|-----------|------------|-------------|-------------|--------------|--------|--------|
| | | | | Share # 1 | 0.000 | \$0.00 | 0.000 | \$0.00 | 0.000 | \$0.00 |
| | | | | Share # 2 | 6,249.600 | \$31,810.46 | -6,249.600 | -\$31,810.46 | 0.000 | \$0.00 |
| 2230 | 685.12 | LF | \$5.090 | 201.600 | \$1,026.14 | -201.600 | -\$1,026.14 | 0.000 | \$0.00 | |
| YELLOW EPOXY REFLECTORIZED PAVEMENT STRIPES - 20 MILS | | | | | | | | | | |

Reason: This decrease to the contract quantity is due to the elimination of this item from the contract.

| Funding Details | | | | | | | | | | |
|-----------------------|-------------|----|---------|------------|-------------|-------------|--------------|-------------|--------|--------|
| | | | | Share # 1 | 0.000 | \$0.00 | 0.000 | \$0.00 | 0.000 | \$0.00 |
| | | | | Share # 2 | 201.600 | \$1,026.14 | -201.600 | -\$1,026.14 | 0.000 | \$0.00 |
| 2240 | 691.0400002 | DC | \$1.000 | 12,240.000 | \$12,240.00 | -12,240.000 | -\$12,240.00 | 0.000 | \$0.00 | |
| TRAINING REQUIREMENTS | | | | | | | | | | |

Reason: This decrease to the contract quantity is due to the elimination of this item, which was requested by the contractor and agreed to by the NYSDOT Region LPU.

| Funding Details | | | | | | | | | | |
|-----------------|--|--|--|-----------|------------|----------------|-------------|-----------------|-------|--------------|
| | | | | Share # 1 | 0.000 | \$0.00 | 0.000 | \$0.00 | 0.000 | \$0.00 |
| | | | | Share # 2 | 12,240.000 | \$12,240.00 | -12,240.000 | -\$12,240.00 | 0.000 | \$0.00 |
| 34 items | | | | Totals | | \$1,691,177.55 | | -\$1,395,716.36 | | \$295,461.19 |

New Items

| Line Number | Item ID | Unit | Quantity | Unit Price | Extension |
|------------------------------|---------|------|----------|------------|-----------|
| Section: 1 - Share #1 | | | | | |

| | | | | | |
|------|---------|----|-------|-------------|-------------|
| 0072 | 206.05A | EA | 9.000 | \$8,416.080 | \$75,744.72 |
|------|---------|----|-------|-------------|-------------|

Test Pit Excavation (Changed Condition)

Reason: This NEW item is being added to the contract to facilitate payment to the contractor for the test pits required at proposed traffic signal poles per SS 680-3.10A. These test pits require deeper excavation and additional manpower to reach the full depth of the Type M Foundations, which are 12'-6" deep with a 4.0' diameter. This project has utilities at varying depths from 3.0' to 11.0' deep. The limited information from the utility owners was either inaccurate or incomplete at the time of design phase and could not be accurately reflected in the contract plans. All provisions of Standard Specification Section 206 shall apply, except that payment shall be made by this Agreed Price.

Funding Details

| | | | |
|-----------|-------|-------------|-------------|
| Share # 1 | 9.000 | \$8,416.080 | \$75,744.72 |
|-----------|-------|-------------|-------------|

| | | | | | |
|------|---------|----|---------|-------------|----------------|
| 0292 | 950.04A | CY | 520.000 | \$2,491.570 | \$1,295,616.40 |
|------|---------|----|---------|-------------|----------------|

Stamped Colored Concrete Sidewalk

Reason: This NEW item is being added to the contract to facilitate payment to the contractor for construction of stamped, colored concrete sidewalks within the historical district, per the requirements for the City of Newburgh. This work is replacing item 608.0101, which does not include the addition of color or imprinting. See the attached Agreed Price Package with Special Specification.

Funding Details

| | | | |
|-----------|---------|-------------|----------------|
| Share # 1 | 520.000 | \$2,491.570 | \$1,295,616.40 |
|-----------|---------|-------------|----------------|

| | | | | | |
|------|-----------|----|--------|-------------|--------------|
| 0305 | 950.0401A | EA | 34.000 | \$9,200.460 | \$312,815.64 |
|------|-----------|----|--------|-------------|--------------|

Curb Ramp Type 1 with Colored Concrete, Pro350 Sealer & Slip Resistant

Reason: This NEW item is being added to the contract to facilitate payment to the contractor for the revision to the Type 1 curb ramps including colored concrete as required in the historic district of Newburgh. See the attached Agreed Price Package with Special Specification. Payment shall be made by this Agreed Price.

| Line Number | Item ID | Unit | Quantity | Unit Price | Extension |
|-------------|---------|------|----------|------------|-----------|
|-------------|---------|------|----------|------------|-----------|

| | | | | |
|------------------------|--|--|--|--|
| Funding Details | | | | |
|------------------------|--|--|--|--|

| | | | | | |
|------|-----------|-----------|--------|--------------|--------------|
| | | Share # 1 | 34.000 | \$9,200.460 | \$312,815.64 |
| 0315 | 950.0402A | EA | 1.000 | \$10,633.720 | \$10,633.72 |

Curb Ramp Type 9 with Colored Concrete, Pro350 Sealer & Slip Resistant

Reason: This NEW item is being added to the contract to facilitate payment to the contractor for the revision to the Type 9 curb ramps including colored concrete as required in the historic district of Newburgh. See the attached Agreed Price Package with Special Specification. Payment shall be made by this Agreed Price.

| | | | | |
|------------------------|--|--|--|--|
| Funding Details | | | | |
|------------------------|--|--|--|--|

| | | | | | |
|------|-----------|-----------|-------|--------------|-------------|
| | | Share # 1 | 1.000 | \$10,633.720 | \$10,633.72 |
| 0325 | 950.0403A | EA | 2.000 | \$9,757.190 | \$19,514.38 |

Curb Ramp Type 11 with Colored Concrete, Pro350 Sealer & Slip Resistant

Reason: This NEW item is being added to the contract to facilitate payment to the contractor for the revision to the Type 11 curb ramps including colored concrete as required in the historic district of Newburgh. See the attached Agreed Price Package with Special Specification. Payment shall be made by this Agreed Price.

| | | | | |
|------------------------|--|--|--|--|
| Funding Details | | | | |
|------------------------|--|--|--|--|

| | | | | | |
|------|---------------|-----------|-------|-------------|-------------|
| | | Share # 1 | 2.000 | \$9,757.190 | \$19,514.38 |
| 0882 | 680.80324603A | EA | 4.000 | \$2,890.330 | \$11,561.32 |

Microcomputer Traffic Control Cabinet Base (Painted)

Reason: This NEW item is being added to the contract to facilitate payment to the contractor for the Microcomputer Traffic Control Cabinet Bases that need to be added to the contract due to a design revision changing from pole-mounted to ground-mounted cabinets. See the attached Agreed Price Package with Special Specification. Payment shall be made by this Agreed Price.

| | | | | |
|------------------------|--|--|--|--|
| Funding Details | | | | |
|------------------------|--|--|--|--|

| | | | | | |
|--|--|-----------|-------|-------------|-------------|
| | | Share # 1 | 4.000 | \$2,890.330 | \$11,561.32 |
|--|--|-----------|-------|-------------|-------------|

| Line Number | Item ID | Unit | Quantity | Unit Price | Extension |
|------------------------------|---------|------|----------|------------|-----------|
| Section: 2 - Share #2 | | | | | |

| | | | | | |
|------|---------|----|-------|-------------|-------------|
| 1212 | 206.05A | EA | 4.000 | \$8,416.080 | \$33,664.32 |
|------|---------|----|-------|-------------|-------------|

Test Pit Excavation (Changed Condition)

Reason: This NEW item is being added to the contract to facilitate payment to the contractor for the test pits required at proposed traffic signal poles per SS 680-3.10A. These test pits require deeper excavation and additional manpower to reach the full depth of the Type M Foundations, which are 12'-6" deep with a 4.0' diameter. This project has utilities at varying depths from 3.0' to 11.0' deep. The limited information from the utility owners was either inaccurate or incomplete at the time of design phase and could not be accurately reflected in the contract plans. All provisions of Standard Specification Section 206 shall apply, except that payment shall be made by this Agreed Price.

| Funding Details | | | |
|-----------------|-------|-------------|-------------|
| Share # 2 | 4.000 | \$8,416.080 | \$33,664.32 |

| | | | | | |
|------|---------|----|---------|-------------|--------------|
| 1432 | 950.04A | CY | 200.000 | \$2,491.570 | \$498,314.00 |
|------|---------|----|---------|-------------|--------------|

Stamped Colored Concrete Sidewalk

Reason: This NEW item is being added to the contract to facilitate payment to the contractor for construction of stamped, colored concrete sidewalks within the historical district, per the requirements for the City of Newburgh. This work is replacing item 608.0101, which does not include the addition of color or imprinting. See the attached Agreed Price Package with Special Specification.

| Funding Details | | | |
|-----------------|---------|-------------|--------------|
| Share # 2 | 200.000 | \$2,491.570 | \$498,314.00 |

| | | | | | |
|------|-----------|----|--------|-------------|--------------|
| 1445 | 950.0401A | EA | 12.000 | \$9,200.460 | \$110,405.52 |
|------|-----------|----|--------|-------------|--------------|

Curb Ramp Type 1 with Colored Concrete, Pro350 Sealer & Slip Resistant

Reason: This NEW item is being added to the contract to facilitate payment to the contractor for the revision to the Type 1 curb ramps including colored concrete as required in the historic district of Newburgh. See the attached Agreed Price Package with Special Specification. Payment shall be made by this Agreed Price.

| Funding Details | | | |
|-----------------|--------|-------------|--------------|
| Share # 2 | 12.000 | \$9,200.460 | \$110,405.52 |

| Line Number | Item ID | Unit | Quantity | Unit Price | Extension |
|-------------|---------|------|----------|------------|-----------|
|-------------|---------|------|----------|------------|-----------|

| | | | | | |
|------|-----------|----|-------|--------------|-------------|
| 1455 | 950.0402A | EA | 1.000 | \$10,633.720 | \$10,633.72 |
|------|-----------|----|-------|--------------|-------------|

Curb Ramp Type 9 with Colored Concrete, Pro350 Sealer & Slip Resistant

Reason: This NEW item is being added to the contract to facilitate payment to the contractor for the revision to the Type 9 curb ramps including colored concrete as required in the historic district of Newburgh. See the attached Agreed Price Package with Special Specification. Payment shall be made by this Agreed Price.

| Funding Details | | | | |
|-----------------|--|--|--|--|
|-----------------|--|--|--|--|

| | | | |
|-----------|-------|--------------|-------------|
| Share # 2 | 1.000 | \$10,633.720 | \$10,633.72 |
|-----------|-------|--------------|-------------|

| | | | | | |
|------|---------------|----|-------|-------------|------------|
| 2022 | 680.80324603A | EA | 2.000 | \$2,890.330 | \$5,780.66 |
|------|---------------|----|-------|-------------|------------|

Microcomputer Traffic Control Cabinet Base (Painted)

Reason: This NEW item is being added to the contract to facilitate payment to the contractor for the Microcomputer Traffic Control Cabinet Bases that need to be added to the contract due to a design revision changing from pole-mounted to ground-mounted cabinets. See the attached Agreed Price Package with Special Specification. Payment shall be made by this Agreed Price.

| Funding Details | | | | |
|-----------------|--|--|--|--|
|-----------------|--|--|--|--|

| | | | |
|-----------|-------|-------------|------------|
| Share # 2 | 2.000 | \$2,890.330 | \$5,780.66 |
|-----------|-------|-------------|------------|

| | | | | |
|----------|-----------------------|--|--|--|
| 11 items | Total: \$2,384,684.40 | | | |
|----------|-----------------------|--|--|--|

Funding Summary

| Fund Package | Original Amount | Authorized Amount | Pending Change | Revised Amount |
|-----------------|-----------------|-------------------|----------------|----------------|
| Share # 1 | \$5,170,815.00 | \$5,170,815.00 | \$692,941.37 | \$5,863,756.37 |
| Share # 2 | \$1,632,888.26 | \$1,632,888.26 | \$296,026.67 | \$1,928,914.93 |
| 2 fund packages | \$6,803,703.26 | \$6,803,703.26 | \$988,968.04 | \$7,792,671.30 |

(Sponsor) Certificate of Recommended Order on Contract

PIN 8005.26 LD036472

City of Newburgh Purchase Order No.: 38718

PIN 8758.75 LD036469

Contractor Name: Verde Electric Maintenance Corporation

Change Order No. 01

I, Arlisa McGrath, RE, hereby certify that I am the officially designated Resident Engineer of the subject project, that the adjustments here within and the material incorporated under the subject contract as stated in the Change Order No. 01 are necessary, and to the best of my knowledge and belief, the said information is correct and in strict compliance with the terms of the said contract.

I further certify that the records from which this order on contract was developed and any other record required by stature, rule or regulation of the New York State Department of Transportation or the Federal Government or prescribed in the contract have been established and will be filed in the Consultant's Office, in accordance with the terms of the contract.

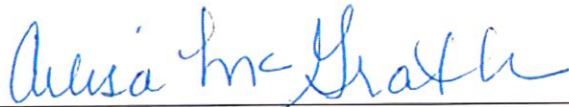

4/27/26

Arlisa McGrath, WSP USA Engineering, Resident Engineer

Date

Jason Morris, PE - Interim City Manager,
Commissioner of Public Works and City Engineer

Date

Change Order Details:

PINS 8005.26 & 8758.75 BROADWAY PTS

04/27/2026

Page 18 of 18

PROJECT: PIN 8005.26 & 8758.75 - Broadway Pedestrian and Traffic Signal Improvements
 SUBJECT: MAJOR ITEM ANALYSIS

| ITEM NO. | DESCRIPTION | UNIT | QTY | ENG EST | | ENG EST | | BIDDER I: Verde Electric Maintenance Corp. | | | | | |
|--------------|---|------|----------|------------|--------------|---------|---------------|--|--------------|----------------|----------|------------------------|-----------------------------|
| | | | | UNIT PRICE | TOTAL | CO 001 | CO \$ | UNIT PRICE | TOTAL price | HIGH BID LIMIT | HIGH BID | MAJOR > \$98,290.56 | RENEGOTIATION THRESHOLDS |
| 207.22 | GEOTEXTILE DRAINAGE | SY | 530 | \$5.00 | \$2,650.00 | -530 | -\$9,587.70 | \$18.09 | \$9,587.70 | \$6.25 | YES | | 1060 |
| 490.30 | MISCELLANEOUS COLD MILLING OF BITUMINOUS CONCRETE | SY | 340 | \$25.00 | \$8,500.00 | -340 | -\$25,625.80 | \$75.37 | \$25,625.80 | \$31.25 | YES | | 680 |
| 608.0101 | CONCRETE SIDEWALKS AND DRIVEWAYS | CY | 690 | \$850.00 | \$586,500.00 | -535 | -\$564,473.15 | \$1,055.09 | \$728,012.10 | \$1,062.50 | | Y | 517.5 862.5 |
| 608.01050109 | CURB RAMP CONFIGURATION TYPE I | EA | 58 | \$7,000.00 | \$406,000.00 | -45 | -\$307,484.10 | \$6,832.98 | \$396,312.84 | \$8,750.00 | | Y | 43.5 72.5 |
| 608.01050909 | CURB RAMP CONFIGURATION TYPE 9 | EA | 2 | \$7,000.00 | \$14,000.00 | -2 | -\$24,317.38 | \$12,158.69 | \$24,317.38 | \$8,750.00 | YES | | 4 |
| 608.01051109 | CURB RAMP CONFIGURATION TYPE 11 | EA | 2 | \$7,000.00 | \$14,000.00 | -2 | -\$13,465.00 | \$6,732.50 | \$13,465.00 | \$8,750.00 | | | 4 |
| 608.13000039 | PRECAST CONCRETE PERMEABLE PAVERS FOR SIDEWALKS AND DRIVEWAYS | SY | 392 | \$300.00 | \$117,600.00 | -392 | -\$70,901.04 | \$180.87 | \$70,901.04 | \$375.00 | | | 784 |
| 609.02160011 | STONE CURB (BLUESTONE) | LF | 220 | \$115.00 | \$25,300.00 | -220 | -\$21,003.40 | \$95.47 | \$21,003.40 | \$143.75 | | | 440 |
| 610.14000011 | STRUCTURAL SOIL MIX | CY | 50 | \$150.00 | \$7,500.00 | -50 | -\$7,536.50 | \$150.73 | \$7,536.50 | \$187.50 | | | 100 |
| 614.060204 | TREE REMOVAL OVER 6 INCHES TO 12 INCHES DIAMETER BREAST HEIGHT - STUMPS GRUBBED | EA | 2 | \$1,000.00 | \$2,000.00 | -1 | -\$2,512.13 | \$2,512.13 | \$5,024.26 | \$1,250.00 | YES | | 4 |
| 619.080101 | REMOVE PAVEMENT MARKING STRIPES, TRAFFIC PAINT | LF | 19500 | \$1.00 | \$19,500.00 | -19500 | -\$88,140.00 | \$4.52 | \$88,140.00 | \$1.25 | YES | | 39000 |
| 634.06010007 | RELOCATE PARKING METER | EA | 11.00 | \$500.00 | \$5,500.00 | -11 | -\$11,053.35 | \$1,004.85 | \$11,053.35 | \$625.00 | YES | | 22 |
| 634.0607001 | DOUBLE MANUAL VANDAL - RESISTANT PARKING METERS, WITH A SINGLE COLLECTION BOX | EA | 6 | \$500.00 | \$3,000.00 | -6 | -\$57,276.48 | \$9,546.08 | \$57,276.48 | \$625.00 | YES | | 12 |
| 655.0502001 | WATERTIGHT SANITARY MANHOLE FRAMES AND COVERS (CASTINGS) | EA | 11.00 | \$900.00 | \$9,900.00 | -1 | -\$4,521.83 | \$4,521.83 | \$49,740.13 | \$1,125.00 | YES | | 22 |
| 685.11 | WHITE EPOXY REFLECTORIZED PAVEMENT STRIPES - 20 MILS | LF | 26040.00 | \$1.50 | \$39,060.00 | -26040 | -\$132,543.60 | \$5.09 | \$132,543.60 | \$1.88 | YES | Y | 19530 32550 |
| 685.12 | YELLOW EPOXY REFLECTORIZED PAVEMENT STRIPES - 20 MILS | LF | 840.00 | \$1.50 | \$1,260.00 | -840 | -\$4,275.60 | \$5.09 | \$4,275.60 | \$1.88 | YES | | 1680 |
| 691.0400002 | TRAINING REQUIREMENTS | DC | 51000.00 | \$1.00 | \$51,000.00 | -51000 | -\$51,000.00 | \$1.00 | \$51,000.00 | \$1.25 | | | 102000 |

**NEW YORK STATE DEPARTMENT OF TRANSPORTATION
AUTHORIZATION OF EXTRA WORK**

| | | | | | |
|--|----------------|---|--|-------------------|--|
| Region # 08 | D036472 | PIN: | 8005.26 & 8758.75 | AEW #: | 002 |
| County/Countries: Orange | | Date: | | 04/03/2026 | |
| Contract Description: Broadway Pedestrian and Traffic Signal Improvements, City of Newburgh | | | | | |
| Engineer-in-Charge: Chad Wade | | | Field Office Fax: | | |
| Contractor: Verde Electric, Inc. | | | | | |
| Is Contract FHWA RFA or NCA? | | <input type="checkbox"/> Yes <input checked="" type="checkbox"/> No | FHWA Concurrence Obtained? | | <input type="checkbox"/> Yes <input checked="" type="checkbox"/> N/A |
| Municipal/Local Share Involvement? | | <input checked="" type="checkbox"/> Yes <input type="checkbox"/> No | Sufficient Funding in Place? | | <input checked="" type="checkbox"/> Yes <input type="checkbox"/> No |
| Proposed Work within the Contract Limits? | | <input checked="" type="checkbox"/> Yes <input type="checkbox"/> No | Proposed work within the Contract Scope? | | <input checked="" type="checkbox"/> Yes <input type="checkbox"/> No |
| Significant Change? | | <input type="checkbox"/> Yes <input checked="" type="checkbox"/> No | Has Project Manager been Notified? | | <input checked="" type="checkbox"/> Yes <input type="checkbox"/> No |
| Contract Bid Amount: \$6,803,703.96 | | | Contract Current Amount: \$6,803,703.96 | | |

Estimated Increase Due to this Change: **\$2,384,684.40**

Description of Proposed Extra Work:
New Agreed Price items for stamped colored concrete sidewalks and colored ADA Ramps; stamped colored concrete was not included in the original design as required in the historical district of downtown Newburgh. Test Pits - additional test pits were required for Traffic Signal Pole deep foundation installation due to unforeseen underground utility changed conditions. The traffic signal pole mounted microcomputer cabinet was changed to a ground mounted cabinet and will require the cabinet base.
The new items added below will be offset by items of work that will be eliminated -

950.04A - Stamped Colored Concrete
950.0401A - Colored Concrete for Type 1 Curb Ramp w/sealer and slip resistance
950.0402A - Colored Concrete for Type 9 Curb Ramp w/sealer and slip resistance
950.0403A - Colored Concrete for Type 11 Curb Ramp w/sealer and slip resistance
206.05A - Test Pit Excavation (Changed Conditions - underground utilities)
680.80324603A - Microcomputer Traffic Control Cabinet Base (Painted)

See see page 3 for spreadsheet breakdown of items to be eliminated to offset new items added

Items Included in Description of Proposed Extra Work

| Item No. | Description | Unit of Measure | Original Bid Quantity | Authorized To Date Quantity | Added Quantity | Price Type | Unit Price |
|-----------|---------------------------------------|-----------------|-----------------------|-----------------------------|----------------|--------------|-------------|
| 950.04A | Stamped Colored Concrete Sidewalk | CY | 0.00 | 0.00 | 720.00 | Agreed Price | \$2,491.57 |
| 950.0401A | Colored Concrete for Type 1 Curb Ramp | EA | 0.00 | 0.00 | 46.00 | Agreed Price | \$9,200.46 |
| 950.0402A | Colored Concrete for Type 9 Curb Ramp | EA | 0.00 | 0.00 | 2.00 | Agreed Price | \$10,633.72 |

AEW has a value less than \$50,000 AEW has a value between \$50,000 & \$100,000 AEW has a value greater than \$100,000

Send a copy back to the EIC and the CO Specialist

| | |
|-----------------------|-----------------------|
| Estimated AEW Total : | \$2,384,684.40 |
|-----------------------|-----------------------|

RECOMMENDED:

Area Construction Supervisor
Resident Engineer, WSP

Amy McGrath

Date: 4/20/26

APPROVED:

Regional Construction Engineer
City of Newburgh

[Signature]

Date: 4/26/26

PROJECT: PIN 8005.26 & 8758.75 - Broadway Pedestrian and Traffic Signal Improvements
 CONTRACTOR: VERDE ELECTRIC MAINTENANCE CORP.
 SUBJECT: CHANGE ORDER 001 ITEM TABLE OF INCREASES AND DECREASES

| ITEM NO. | DESCRIPTION | UNIT | TOTAL ORIGINAL QTY | UNIT PRICE | CO 001 SHARE 1 | CO \$ SHARE 1 | CO 001 SHARE 2 | CO \$ SHARE 2 | CO 001 QUANTITY | CO 001 TOTAL \$ |
|----------|-------------|------|--------------------|------------|----------------|---------------|----------------|---------------|-----------------|-----------------|
|----------|-------------|------|--------------------|------------|----------------|---------------|----------------|---------------|-----------------|-----------------|

DECREASES

| | | | | | | | | | | |
|--------------|---|----|----------|-------------|-----------|-----------------|----------------|-----------------|-----------|---------------|
| 207.22 | GEOTEXTILE DRAINAGE | SY | 530 | \$18.09 | -402.8 | -\$7,286.65 | \$ (127.20) | \$ (2,301.05) | -530.00 | -\$9,587.70 |
| 490.30 | MISCELLANEOUS COLD MILLING OF BITUMINOUS CONCRETE | SY | 340 | \$75.37 | -258.4 | \$ (19,475.61) | \$ (81.60) | \$ (6,150.19) | -340.00 | -\$25,625.80 |
| 608.0101 | CONCRETE SIDEWALKS AND DRIVEWAYS | CY | 690 | \$1,055.09 | -400 | \$ (422,036.00) | \$ (135.00) | \$ (142,437.15) | -535.00 | -\$564,473.15 |
| 608.01050109 | CURB RAMP CONFIGURATION TYPE 1 | EA | 58 | \$6,832.98 | -31.08 | \$ (212,369.02) | \$ (13.92) | \$ (95,115.08) | -45.00 | -\$307,484.10 |
| 608.01050909 | CURB RAMP CONFIGURATION TYPE 9 | EA | 2 | \$12,158.69 | -1.52 | \$ (18,481.21) | \$ (0.48) | \$ (5,836.17) | -2.00 | -\$24,317.38 |
| 608.01051109 | CURB RAMP CONFIGURATION TYPE 11 | EA | 2 | \$6,732.50 | -1.52 | \$ (10,233.40) | \$ (0.48) | \$ (3,231.60) | -2.00 | -\$13,465.00 |
| 608.13000039 | PRECAST CONCRETE PERMEABLE PAVERS FOR SIDEWALKS AND DRIVEWAYS | SY | 392 | \$180.87 | -297.92 | \$ (53,884.79) | \$ (94.08) | \$ (17,016.25) | -392.00 | -\$70,901.04 |
| 609.02160011 | STONE CURB (BLUESTONE) | LF | 220 | \$95.47 | -167.2 | \$ (15,962.58) | \$ (52.80) | \$ (5,040.82) | -220.00 | -\$21,003.40 |
| 610.14000011 | STRUCTURAL SOIL MIX | CY | 50 | \$150.73 | -38 | \$ (5,727.74) | \$ (12.00) | \$ (1,808.76) | -50.00 | -\$7,536.50 |
| 614.060204 | TREE REMOVAL OVER 6 INCHES TO 12 INCHES DIAMETER BREAST HEIGHT - STUMPS GRUBBED | EA | 2 | \$2,512.13 | -0.52 | \$ (1,306.31) | \$ (0.48) | \$ (1,205.82) | -1.00 | -\$2,512.13 |
| 619.080101 | REMOVE PAVEMENT MARKING STRIPES, TRAFFIC PAINT | LF | 19500 | \$4.52 | -14820.00 | \$ (66,986.40) | \$ (4,680.00) | \$ (21,153.60) | -19500.00 | -\$88,140.00 |
| 634.06010007 | RELOCATE PARKING METER | EA | 11.00 | \$1,004.85 | -8.36 | \$ (8,400.55) | \$ (2.64) | \$ (2,652.80) | -11.00 | -\$11,053.35 |
| 634.0607001 | DOUBLE MANUAL VANDAL - RESISTANT PARKING METERS, WITH A SINGLE COLLECTION BOX | EA | 6 | \$9,546.08 | -4.56 | \$ (43,530.12) | \$ (1.44) | \$ (13,746.36) | -6.00 | -\$57,276.48 |
| 655.0502001 | WATER TIGHT SANITARY MANHOLE FRAMES AND COVERS (CASTINGS) | EA | 11 | \$4,521.83 | -1 | \$ (4,521.83) | \$ - | \$ - | -1.00 | -\$4,521.83 |
| 685.11 | WHITE EPOXY REFLECTORIZED PAVEMENT STRIPES - 20 MILS | LF | 26040.00 | \$5.09 | -19790.40 | \$ (100,733.14) | \$ (6,249.60) | \$ (31,810.46) | -26040.00 | -\$132,543.60 |
| 685.12 | YELLOW EPOXY REFLECTORIZED PAVEMENT STRIPES - 20 MILS | LF | 840.00 | \$5.09 | -638.4 | \$ (3,249.46) | \$ (201.60) | \$ (1,026.14) | -840.00 | -\$4,275.60 |
| 691.0400002 | TRAINING REQUIREMENTS | DC | 51000.00 | \$1.00 | -38760.00 | \$ (38,760.00) | \$ (12,240.00) | \$ (12,240.00) | -51000.00 | -\$51,000.00 |

Decrease -\$1,395,717.06

INCREASES

| | | | | | | | | | | |
|------------|--|----|---|--------------|--------|-----------------|-----------|---------------|--------|-----------------|
| 950.04A | STAMPED COLORED CONCRETE SIDEWALK | CY | 0 | \$ 2,491.57 | 520.00 | \$ 1,295,616.40 | \$ 200.00 | \$ 498,314.00 | 720.00 | \$ 1,793,930.40 |
| 950.0401A | COLORED CONCRETE FOR TYPE I CURB RAMP | EA | 0 | \$ 9,200.46 | 34.00 | \$ 312,815.64 | \$ 12.00 | \$ 110,405.52 | 46.00 | \$ 423,221.16 |
| 950.0402A | COLORED CONCRETE FOR TYPE 9 CURB RAMP | EA | 0 | \$ 10,633.72 | 1.00 | \$ 10,633.72 | \$ 1.00 | \$ 10,633.72 | 2.00 | \$ 21,267.44 |
| 950.0403A | COLORED CONCRETE FOR TYPE 11 CURB RAMP | EA | 0 | \$ 9,757.19 | 2.00 | \$ 19,514.38 | \$ - | \$ - | 2.00 | \$ 19,514.38 |
| 206.05A | TEST PIT EXCAVATION (CHANGED CONDITION) | EA | 0 | \$ 8,416.08 | 9.00 | \$ 75,744.72 | \$ 4.00 | \$ 33,664.32 | 13.00 | \$ 109,409.04 |
| 680.803246 | MICROCOMPUTER TRAFFIC CONTROL CABINET BASE | EA | 0 | \$ 2,890.33 | 4.00 | \$ 11,561.32 | \$ 2.00 | \$ 5,780.66 | 6.00 | \$ 17,341.98 |

Increase \$ 2,384,684.40

Contract Increase \$988,967.34

625.09010015 - typo correction to original authorized contract price in appia \$0.70

CO #001 Total \$988,968.04



89 Edison Avenue • Mt. Vernon, New York 10550
Phone 914-664-7000 • Facsimile 914-668-7997

March 25, 2026

WSP Field Office/Broadway TSP
1 Corwin Court, Room 102
Newburgh, NY 10550
Attn: Arlisa McGrath, EIC

RE: Contract Pins 8005.26 and 8758.75
Broadway Pedestrian and Traffic Signal Improvements
VEMC Job #8510 and 8530
Item No. 950.04 – Stamped Colored Concrete Sidewalk
Letter of Concurrence

Dear Arlisa:

Verde Electric Maintenance Corp. accepts the agreed price for:

| | |
|-------------------|-----------------------------------|
| Item No.: | 950.04 |
| Item Description: | Stamped Colored Concrete Sidewalk |
| Quantity: | 720 CY |
| Unit Price: | \$2,491.57 |
| Total Extension: | \$1,793,930.40 |

Please do not hesitate to contact me if you have any questions.

Very truly yours,
Verde Electric Maintenance Corp.

A handwritten signature in blue ink, appearing to read 'Robert Craig', is written over the printed name.

Robert Craig
Vice President

MURK 26
(11/22)

NEW YORK STATE DEPARTMENT OF TRANSPORTATION

Agreed Price Worksheet - Prime Contractor

Contract: 8758.75 Item No.: 950.04 Quantity: 720.00 Units: CY

Item Description : Stamped Colored Concrete

(A) LABOR

| Trade | Reg Hours | Wage Rate | Cost | Fringe Hours | Fringe Rate | Cost |
|----------------------------|-----------|-----------|-------------|--------------|-------------|-------------|
| General Foreman LU137 | 1,360 | \$ 65.26 | \$88,753.60 | 1,360 | \$ 50.46 | \$68,625.60 |
| Laborer - CL2 LU60 | 5,440 | \$ 50.71 | 275,862.4 | 5,440 | \$ 34.82 | 189,420.8 |
| ACI Concrete Finisher LU60 | 1,360 | \$ 56.27 | \$76,527.20 | 1,360 | \$ 35.14 | \$47,790.40 |
| | | | | | | |
| | | | | | | |
| | | | | | | |
| | | | | | | |
| | | | | | | |

Wages 441,143.2 Fringes 305,836.8

If Fringes are paid directly to employee via cash or check, Enter value here:

\$ 0.00
Worker's Compensation Rate (%): 14.56 %

Total of Wages and Fringes: 746,980
Workers Compensation: \$64,230.45
Standard Labor Markup: \$55,142.90
Fringe Benefit Markup: \$ 0.00
Labor Total: 866,353.34992

(The Contractor shall submit an insurance policy declaration / rate page from its insurer to validate the Workers Comp insurance rate based on an EMR of 1.0.)

(B) MATERIALS

| Description | Units | # of Units | Cost/Unit | Cost | Description | Units | # of Units | Cost/Unit | Cost |
|---------------------|-------|------------|------------|-------------|----------------------|-------|------------|------------|--------------|
| Stamps & Tools | SET | 0.00 | \$3,319.84 | \$0.00 | Wire Mesh - 5'x10' | EA | 1,262.00 | \$17.43 | \$21,996.66 |
| Liquid Release | PAIL | 83.00 | \$138.14 | \$11,465.62 | Exp Joint(120'per) | LF | 4,080.00 | \$0.75 | \$3,060.00 |
| Pro350 Sealer | PAIL | 43.00 | \$289.17 | \$12,434.31 | Cl D Concrete Dyed | CY | 734.00 | \$301.54 | \$221,330.36 |
| Slip-Resist Additiv | BOX | 43.00 | \$21.57 | \$927.51 | Lumber + Paint Tools | LS | 1.00 | \$6,991.55 | \$6,991.55 |

Materials Total: \$278,206.01

(C) EQUIPMENT

| Description | Hours | FHWA Rate | Cost | Description | Hours | FHWA Rate | Cost |
|--------------------------|----------|-----------|-------------|--------------|----------|-----------|--------------|
| Pickup Truck | 1,360.00 | \$41.11 | \$55,909.60 | Pickup Truck | 0.00 | \$41.11 | \$0.00 |
| Rack Truck w/ Water Tank | 136.00 | \$86.75 | \$11,798.00 | Box Truck | 1,360.00 | \$86.75 | \$117,980.00 |
| Generator | 1,360.00 | \$5.90 | \$8,024.00 | Concrete Saw | 136.00 | \$62.05 | \$8,438.80 |
| Pressure Washer | 136.00 | \$4.66 | \$633.76 | | | | |

Equipment Total: 202,784.16

(D) SERVICES

| Description / Type | # of Units | Cost / Unit | Cost | Description / Type | # of Units | Cost / Unit | Cost |
|--------------------|------------|-------------|------|--------------------|------------|-------------|------|
| | | | | | | | |
| | | | | | | | |

Services Total:

(E) OVERHEAD & PROFIT

| | OH & Profit % | Cost |
|--------------------------------------|---------------|--------------|
| Labor, Materials, & Equipment Total: | 20.00 | \$269,468.70 |
| Services: | 20.00 | \$ 0.00 |

Overhead & Profit Total: 269,468.703984

(F) INSURANCE

Enter rate here if based on payroll

Payroll Based Cost Basis 40.15 % \$ 441,143.20

Enter rate here if based on sales

Sales Based Cost Basis \$ 0.00

Insurance Total: 177,118.9948

Item Total: \$1,793,931.22

Unit Price: \$ 2,491.57 per CY

Robert Craig Digitally signed by Robert Craig Date: 2026.03.24 16:13:38 C4 00' 3-24-26 Arlisa McGrath Arlisa McGrath 4/10/26
Contractor's Rep Name Signature Date Engineer-in-Charge's Name Signature Date

VERDE ELECTRIC CORP LABOR RATE BREAKDOWN

EFFECTIVE DATES:

FROM: 3/4/2025
 TO: 3/3/2026

TRADE CLASSIFICATION: OPERATORS OS FOREMAN

UNION: OPERATING ENGINEERS
 LOCAL NO: 137

| | | Straight Time | Overtime & Saturday | Sunday |
|---|---------|------------------|------------------------|------------------|
| 1 HOURLY RATE | | \$ 65.26 | \$ 97.89 | \$ 130.52 |
| 2 FRINGES: | | RATE | | |
| Welfare | \$21.40 | \$ 21.40 | \$21.40 | \$ 21.40 |
| Vacation | \$3.20 | \$ 3.20 | \$ 3.20 | \$ 3.20 |
| Savings/PSL | \$1.10 | \$ 1.10 | \$ 1.10 | \$ 1.10 |
| Pension | \$5.18 | \$ 5.18 | \$ 5.18 | \$ 5.18 |
| Apprenticeship | \$1.30 | \$ 1.30 | \$ 1.30 | \$ 1.30 |
| National Training | \$0.10 | \$ 0.10 | \$ 0.10 | \$ 0.10 |
| Annuity | \$8.50 | \$ 8.50 | \$ 8.50 | \$ 8.50 |
| IAF | \$0.50 | \$ 0.50 | \$ 0.50 | \$ 0.50 |
| Supplemental Dues | 3.75% | \$ 2.45 | \$ 3.67 | \$ 4.89 |
| PAC | \$0.05 | \$ 0.05 | \$ 0.05 | \$ 0.05 |
| LMCT | \$1.00 | \$ 1.00 | \$ 1.00 | \$ 1.00 |
| ** Holiday | \$5.68 | \$ 5.68 | \$ 5.68 | \$ 5.68 |
| TOTAL FRINGES: | | \$ 50.46 | \$ 51.68 | \$ 52.90 |
| 3 PAYROLL TAXES & INSURANCE | | RATE | | |
| FICA (Social Security & Medicare) | 7.65% | \$ 4.99 | \$ 7.49 | \$ 9.98 |
| Federal Unemployment | 0.60% | \$ 0.39 | \$ 0.59 | \$ 0.78 |
| Metro Tax | 0.34% | \$ 0.22 | \$ 0.33 | \$ 0.44 |
| New York Unemployment | 8.33% | \$ 5.44 | \$ 8.15 | \$ 10.87 |
| Workers Comp | 7.80% | \$ 5.09 | \$ 5.09 | \$ 5.09 |
| General Liability | 15.50% | \$ 10.12 | \$ 15.17 | \$ 20.23 |
| TOTAL PAYROLL TAXES & INSURANCE: | | \$ 26.25 | \$ 36.83 | \$ 47.40 |
| 4 TOTAL LABOR RATE, FRINGES, TAXES & INSURANCE | | \$ 141.96 | \$ 186.40 | \$ 230.83 |

** Holiday computed as 80 hour cost divided by 1,920 (est. 48 week work year)

VERDE ELECTRIC CORP LABOR RATE BREAKDOWN

EFFECTIVE DATES:

FROM: 3/30/2025
 TO: 3/28/2026

TRADE CLASSIFICATION: GROUP II

UNION: HVY, HWY, UTILITY
 LOCAL NO: 60

| | | Straight Time | Overtime & Saturday | Sunday |
|--|-------------|------------------|---------------------|------------------|
| 1 HOURLY RATE | | | | |
| | | \$ 50.71 | \$ 76.07 | \$ 101.42 |
| 2 FRINGES: | | | | |
| | RATE | | | |
| Welfare | \$10.63 | \$ 10.63 | \$ 10.63 | \$ 10.63 |
| Pension | \$11.15 | \$ 11.15 | \$ 11.15 | \$ 11.15 |
| Annuity | \$6.00 | \$ 6.00 | \$ 6.00 | \$ 6.00 |
| Apprentice & Training | \$1.10 | \$ 1.10 | \$ 1.10 | \$ 1.10 |
| Labor Management | \$0.95 | \$ 0.95 | \$ 0.95 | \$ 0.95 |
| LECET | \$0.15 | \$ 0.15 | \$ 0.15 | \$ 0.15 |
| NY Health and Safety | \$0.10 | \$ 0.10 | \$ 0.10 | \$ 0.10 |
| IAF | \$0.50 | \$ 0.50 | \$ 0.50 | \$ 0.50 |
| ** Holiday | \$4.24 | \$ 4.24 | \$ 4.24 | \$ 4.24 |
| TOTAL FRINGES: | | \$ 34.82 | \$ 34.82 | \$ 34.82 |
| 3 PAYROLL TAXES & INSURANCE | | | | |
| | RATE | | | |
| FICA (Social Security & Medicare) | 7.65% | \$ 3.88 | \$ 5.82 | \$ 7.76 |
| Federal Unemployment | 0.60% | \$ 0.30 | \$ 0.46 | \$ 0.61 |
| Metro Tax | 0.34% | \$ 0.17 | \$ 0.26 | \$ 0.34 |
| New York Unemployment | 8.33% | \$ 4.22 | \$ 6.33 | \$ 8.44 |
| Workers Comp | 7.80% | \$ 3.96 | \$ 3.96 | \$ 3.96 |
| General Liability | 15.50% | \$ 7.86 | \$ 11.79 | \$ 15.72 |
| TOTAL PAYROLL TAXES & INSURANCE: | | \$ 20.39 | \$ 28.61 | \$ 36.83 |
| 4 TOTAL LABOR RATE, TAXES & INSURANCE | | | | |
| | | \$ 105.92 | \$ 139.49 | \$ 173.07 |

** Holiday computed as 80 hour cost divided by 1,920 (est. 48 week work year)

VERDE ELECTRIC CORP LABOR RATE BREAKDOWN

EFFECTIVE DATES:

FROM: 3/30/2025
TO: 3/28/2026

TRADE CLASSIFICATION:

GROUP I

UNION:

HVY, HWY, UTILITY

LOCAL NO:

60

| | | Straight Time | Overtime & Saturday | Sunday |
|--|-------------|------------------|---------------------|------------------|
| 1 HOURLY RATE | | | | |
| | | \$ 56.27 | \$ 84.41 | \$ 112.54 |
| 2 FRINGES: | | | | |
| | RATE | | | |
| Welfare | \$10.63 | \$ 10.63 | \$ 10.63 | \$ 10.63 |
| Pension | \$11.15 | \$ 11.15 | \$ 11.15 | \$ 11.15 |
| Annuity | \$6.00 | \$ 6.00 | \$ 6.00 | \$ 6.00 |
| Apprentice & Training | \$1.10 | \$ 1.10 | \$ 1.10 | \$ 1.10 |
| Labor Management | \$0.95 | \$ 0.95 | \$ 0.95 | \$ 0.95 |
| LECET | \$0.15 | \$ 0.15 | \$ 0.15 | \$ 0.15 |
| NY Health and Safety | \$0.10 | \$ 0.10 | \$ 0.10 | \$ 0.10 |
| IAF | \$0.50 | \$ 0.50 | \$ 0.50 | \$ 0.50 |
| ** Holiday | \$4.56 | \$4.56 | \$ 4.56 | \$ 4.56 |
| TOTAL FRINGES: | | \$ 35.14 | \$ 35.14 | \$ 35.14 |
| 3 PAYROLL TAXES & INSURANCE | | | | |
| | RATE | | | |
| FICA (Social Security & Medicare) | 7.65% | \$ 4.30 | \$ 6.46 | \$ 8.61 |
| Federal Unemployment | 0.60% | \$ 0.34 | \$ 0.51 | \$ 0.68 |
| Metro Tax | 0.34% | \$ 0.19 | \$ 0.29 | \$ 0.38 |
| New York Unemployment | 8.33% | \$ 4.68 | \$ 7.03 | \$ 9.37 |
| Workers Comp | 7.80% | \$ 4.39 | \$ 4.39 | \$ 4.39 |
| General Liability | 15.50% | \$ 8.72 | \$ 13.08 | \$ 17.44 |
| TOTAL PAYROLL TAXES & INSURANCE: | | \$ 22.63 | \$ 31.75 | \$ 40.87 |
| 4 TOTAL LABOR RATE, TAXES & INSURANCE | | | | |
| | | \$ 114.04 | \$ 151.30 | \$ 188.55 |

** Holiday computed as 80 hour cost divided by 1,920 (est. 48 week work year)



OFFER

Cranesville Block Co., Inc.
 1250 Riverfront Center
 Amsterdam, NY 12010
 www.cranesville.com

Phone: 518-684-6000
 Dispatch: 518-684-6085
 Sales: 518-684-6078
 Sales Fax: 518-684-0128
 Credit: 518-684-6004

Ready Mixed Concrete – Aggregates – Masonry Units – Precast – Masonry Supplies

Customer Name Verde Electric
 Attention Anthony Mauriello
 Office Phone (914) 664-7000
 Cell Phone (914) 652-3908
 Email amauriello@verdeelectric.com
 Fax (914) 668-7997
 Yards 800
 Quote Number 00011972

Project Name Broadway Improvements Newburgh
 Project Address Robinson Ave
 Project Newburgh, NY
 Address(Cont'd)
 Quote Date 8/8/2025
 Expiration Date 12/31/2025
 Project Salesman Bill Cobey
 Salesman Mobile 845-313-0626
 Salesman Email wcobey@cranesville.com
 Sales Assoc. Patti Bieniek
 Sales Assoc. Phone 518-684-6119
 Sales Assoc. Email pbieniek@cranesville.com

| Quantity | Product | Line Item Description | Sales Price | UM |
|----------|------------------|--|-------------|----|
| 800.00 | Class D Concrete | Straight Cement for colored concrete (Included 1.5 lbs. fiber for sidewalks) | \$196.45 | CY |

***Due to the potential disruption in the cement supply chain, we reserve the right to requote as necessary.**

Above mixes are designed to have a 2"- 4" slump.
 If a 4"- 6" slump is required a Midrange will need to be used at additional price listed below
 If a 7"-9" slump is required a Super Plasticizer will need to be used at additional price listed below
 Plants are NYSDOT approved; not NRMCA.

Additional Information: SIKA COLOR #14 GRAY (4 BAGS/YARD) \$109.50/CY

**Please see the Terms & Conditions on the last page of this Offer.
 MINIMUM OF A 6% INCREASE ON ALL BELOW PRODUCTS FOR EACH SUBSEQUENT YEAR.**

Class D base price w/ fiber \$196.45/CY

Sample load CID 11 CY @ \$196.45
 sika color 11 CY @ \$109.50
 Environmental Charge 1 ea @ \$13.99
 Color washout 1 ea @ \$50.00
 fuel surcharge 1 ea @ \$25.00

Total: \$3,454.44

deduct Fiber _\$12.45

= ~~\$314.04~~ /CY
 = \$301.59



OFFER

Cranesville Block Co., Inc.
 1250 Riverfront Center
 Amsterdam, NY 12010
 www.cranesville.com

Phone: 518-684-6000
 Dispatch: 518-684-6085
 Sales: 518-684-6078
 Sales Fax: 518-684-0128
 Credit: 518-684-6004

Ready Mixed Concrete – Aggregates – Masonry Units – Precast – Masonry Supplies

Additional Products and Services – Mont / Fish / Lib

| | | | | | |
|---|---------------|--|-------------|-------------------------------|-------------|
| Environmental Surcharge (mandatory) | \$13.99 /load | Small Stone | \$2.75 /cy | Non-Chloride 1% | \$7.15 /cy |
| Fuel Surcharge (mandatory) (subject to change) | \$25.00/load | Fiber (1 lb per cy) | \$9.25 /cy | Non-Chloride 2% | \$11.45 /cy |
| Color Washout | \$50.00 /load | Fiber (1.5 lb per cy) | \$12.45 /cy | Calcium 1% | \$5.55 /cy |
| Saturday Delivery | \$75.00 /load | Mid-Range Water Reducer | \$5.00 /cy | Calcium 2% | \$10.30 /cy |
| Truck Time (Overtime) Charge (per minute) | \$2.00 /min | High Range Water Reducer (Super Plasticizer) | \$9.25 /cy | Retarder | \$5.55 /cy |
| Cold Weather (Exact weather subject to ACI standards) | \$12.50/cy | Corrosion Inhibitor | Inquire | Moisture Vapor Reducing Admix | Inquire |
| Ice (hot weather Concrete) | Inquire | | | | |

Terms and Conditions

Any purchase order sent by Buyer and not signed by an authorized representative of Seller will be invalid, regardless of commencement of delivery.

- This offer is expressly limited to and expressly made conditional on buyer's acceptance of these terms and conditions and (a copy of the Consolidated Joint Application for Extension of Credit available at <https://www.cranesville.com/pdf/ExtApp.pdf>) Seller objects to any different terms and conditions contained in any purchase order or any other document sent by buyer. Seller will not accept terms of any purchase order, which incorporate by reference terms and conditions of a separate and distinct agreement.
- All invoices are due net thirty (30) days from delivery or sale; invoices remaining delinquent beyond thirty (30) days shall bear an 18% per annum finance charge.
- Seller's delivery of goods to buyer constitutes buyer's acceptance of this offer in the absence of buyer's written signature.
- Seller's warranty limited to full refund of purchase price.
- This offer is not contingent upon strikes, riots, authority of law, acts of God and/or other causes beyond our control. Access to the project and individual delivery locations must be such that normal drive ready mixed, boom, tanker, H-cable or hauler trailer trucks can maneuver under their own power at all times. The Seller reserves the right to stop deliveries if roadways or approaches are unsatisfactory to him/her. The buyer assumes all liability for damage to sidewalks, driveways or other property beyond the curb line and agrees to indemnify the Seller against all liability loss and expenses incurred as a result of such delivering including damage to Seller's equipment and loss of time.
- The products have been designed to attain the indicated compressive strengths in accordance with recognized testing methods and standards, field results may differ substantially due to variables such as waiting time, placing methods, weather, handling after placement, addition of outside materials by buyer or request of buyer, such as water, and other variables beyond the control of the Seller. The Seller hereby disclaims any liability and/or warranty expressed or implied should the buyer not use proper testing, placing and curing methods (ACI-ASTM). Upon delivery, it is the buyer's responsibility to confirm the correct product or mix has been delivered. There will be no credit or adjustment to billing for incorrect material incorporated into the work.

- Sales tax will be applied to Seller invoice(s) unless appropriate documentation is received before ordering product.
- Prices are based on full truckloads (7+CY). A short load will be charged on orders less than 7 yds. (Contact sales for a copy of the rates.) A balance on a plus order is one load of ten yards or less.
- Heating or cooling of concrete is not included in product price.
- If color is used on any job, an environmentally approved location must be available for a truck to rinse.
- Hours of operation Monday - Friday 7:00 AM- 8:30 PM. Saturday 8 AM - 12 PM. Contact sales for deliveries outside of these hours.
- All products that are ordered and are not listed on this quote will be billed at the standard price.
- Delivery times and truck spacing are targets Seller strives for but does not guarantee due to the demands of the industry.
- Truck time will be charged after the allotted 6 minutes per yard, per truck, at the rate set forth in the "Additional Products and Services" schedule. Truck time is calculated, by truck, "At Job" until "Stop Pour."
- All offered prices are subject to price increase(s) due to cement and/or fuel cost increases.
- The above pricing is based on the project's total yardage and specified mixes. Seller and other material producing companies reserve the right to re-price based on changes in quantity and/or mix, or extraneous factors. All quoted products are standard mix designs unless specifications have been provided prior to quotation.
- Waiver of Consequential Damages: Purchaser, for good and valuable consideration, and as a condition of purchase, waives against Seller any and all damages arising directly, or as a consequence of, Seller providing defective or non-conforming goods. Such waiver shall include damages arising as a direct or indirect result of costs or property damage, to adjoining work caused or created by non-conforming or defective product provided by Seller.
- The "Expiration Date" includes all terms and pricing listed. Standard pricing will apply thereafter.

Price not enforceable by Buyer if not signed within 15 days of receipt. Please sign offer and return before ordering.

ACCEPTED BY:

DATE:

This is the last page of this Offer.

WHITE CAP®

BUILDING TRUST ON EVERY JOB

ACCOUNT MANAGER: HEATHER SCHEER

HEATHER.SCHEER@WHITECAP.COM

860-573-8566

CUSTOMER: VERDE ELECTRIC

NAME: ANTHONY MAURIELLO

JOB: BROADWAY NEWBURGH PTS

2025-08-06 Whitecap 18x36" Bluestone

| Description | Packaging | Item | Each Unit (ea) | QTY | Total |
|--------------------------------------|----------------|--------|----------------|-----|--------------|
| 18"X36" Bluestone- Rigid Black | 18" x 36" | 599712 | 270.97 | 6 | \$ 1,625.82 |
| 18"X36" Bluestone- Rigid Blue | 18" x 36" | 599714 | 270.97 | 6 | \$ 1,625.82 |
| 18"X36" Bluestone- Rigid Green | 18" x 36" | 599716 | 270.97 | 6 | \$ 1,625.82 |
| 18"X36" Bluestone- Flex Black | 18" x 36" | 599711 | 270.97 | 2 | \$ 541.94 |
| 18"X36" Bluestone Flex Blue | 18" x 36" | 599713 | 270.97 | 2 | \$ 541.94 |
| Bluestone Texture Touch-up Skin | 18" x 18" | 599625 | 104.89 | 2 | \$ 209.78 |
| Bluestone 9" Texture Roller Sleeve | 9" x 3.25" | 600017 | 88.80 | 2 | \$ 177.60 |
| 2" Chisel | 2" x 7.5" | 618415 | 18.34 | 2 | \$ 36.69 |
| 4" Chisel | 4" x 8" | 618416 | 29.94 | 2 | \$ 59.89 |
| 8" Chisel | 8" x 8" | 618417 | 32.99 | 2 | \$ 65.98 |
| 3/16" Touch-Up Wheel | 13.5" x 2.5" | 600666 | 64.21 | 2 | \$ 128.42 |
| Perma-Cast® Clear Liquid Release | 5 Gal. | 619060 | 138.14 | 72 | \$ 9,946.08 |
| SikaCem®-100 PRO 350® | 5 Gal. | 761327 | 289.17 | 37 | \$ 10,699.29 |
| Clear Guard® Slip-Resistant Additive | Box of 6-1 lb. | 618584 | 21.57 | 37 | \$ 798.05 |

Two Sets

Notes:

- Stamp Pattern # S4210
- Recommended Contractor Stamp Set: 9 Rigid, 2 Flex, 1 Skin, 1 Roller Sleeve
- Suggested Touch-Up / Detail Tools- Chisels: 2", 4", 8", & 12" Touch-up Wheel: 3/16"
- Liquid Release Assumes 750 sf./ pail
- Lithochrome Wax assumes 200 Sf/Gal
- Pro 350 assumes 300-400 sq. ft./gal.

Approximate freight \$300.00/pallet
Does not include Taxes
Based on approximate 51,000 SF

WHITE CAP[®] ON ACCOUNT



511 - Newington CT (AHH) (PZ10)
 91 Holmes Rd
 Newington, CT, 06111
 (860) 665-9400

QUOTE

67755862

THIS IS A QUOTE ONLY DO NOT SHIP OR
 TENDER FUNDS

Sold To: 10000215303
 VERDE ELECTRIC
 89 EDISON AVENUE
 MT VERNON, NY, 10550

Ship To: Broadway Traffic Signal Improvements,10005427450
 BROADWAY
 NEWBURGH, NY, 12550
 Job Site Contact: ANTHONY ANTHONY
 Job Site Phone: 914-652-3908
 Map #:

12:45 PM

Ordered By: ANTHONY ANTHONY

Contact Phone: 914-6523908

| Quote Number | | Quote Date | Valid Until | Request Date | Sales Person | |
|--------------|--------------|--|--------------|-----------------|--------------|-------------|
| 67755862 | | 08/12/2025 | 08/19/2025 | 08/12/2025 | Scheer, H | |
| Terms | | Shipping Method | Quote Name | Customer PO | Created By | |
| N30D | | 2. Our Truck | BROADWAY | broadway | Scheer, H | |
| SEQ | Part# H/M | Description | Ord Quantity | U/M Unit WT | Price COO | Amount |
| 10 | 434666G510 | 6"X6" W2.9 6GA 5'X10' WIRE MESH MAT | 1100 | EA 20.69 LBS | \$17.43 | \$19,173.00 |
| 20 | 199EB124010 | 1/2"X4"X10' FIBER EXPANSION BOARD 100FT/BUNDLE | 7500 | FT .32 LBS | \$0.38 | \$2,850.00 |
| 30 | 505VC12 | 1/2"X10' TOP VOID CAP SOLD/FOOT | 7400 | FT .08 LBS | \$0.37 | \$2,738.00 |
| 40 | 3392SPF2416 | 2"X4"X16' #2 SPF LUMBER | 200 | EA 18.66 LBS | \$12.79 | \$2,558.00 |
| 50 | 339CDX3448 | 3/4"X4'X8' CDX PLYWOOD 23/32" 18MM | 80 | EA 60 LBS | \$34.56 | \$2,764.80 |

| | | |
|------------------------|-------|-------------|
| Shipped amount | | \$30,083.80 |
| Order charges | | \$0.00 |
| Tax amount | | \$0.00 |
| Lumber Tax rate/amount | 1.00% | \$0.00 |
| Quote total | | \$30,083.80 |

| ITEM | QTY | Unit Cost | Total |
|-------------------------------|-----|--------------|--------------------|
| Paint Roller | 24 | \$ 4.48 | \$ 107.52 |
| Paint Roller Cover | 200 | \$ 4.16 | \$ 832.00 |
| Paint Tray | 80 | \$ 3.98 | \$ 318.40 |
| Paint Roller Extension Handle | 10 | \$ 27.48 | \$ 274.80 |
| | | Subtotal | \$ 1,532.72 |
| | | Tax | \$ 136.03 |
| | | Total | \$ 1,668.75 |



Mount Ple... 10PM 10532 What can we help you find today?



Shop All

Wooster

9 in. x 1/2 in. Pro Surpass Shed-Resistant Knit High-Density Fabric Roller Cover Applicator/Tool (3-Pack)

★★★★★ (1897) Questions & Answers (20)



RESEALABLE BAG



BULK PRICE \$12.48

Buy 4 or more \$10.61

Buy 4 or More, Get 15% Off

0 of 4 items

Add 4 more to quality

[Shop This Offer](#)

- Fast results
- Shed-resistant knit
- Even coverage
- [View More Details](#)

Mount Pleasant Store

✓ 46 in stock Aisle 36, Bay 006

Package Quantity: 3

1 **3**

Nap Size/Thickness (in.): 1/2

1/2

Product Width (in.): 9 in

9 in

15% Off



Mount Ple... 10PM 10532 What can we help you find today?



Shop All

Paint / Paint Supplies / Paint Roller Extension Poles / Wooster Paint Roller Extension Poles

Internet # 100187725 Model # 00R0550000 Store SKU # 100002232Z

Top Rated

Wooster

Sherlock 4 ft. - 8 ft. Adjustable Extension Pole

★★★★★ (2040) Questions & Answers (47)



\$27.48

Pay \$2.48 after \$25 OFF your total qualifying purchase upon opening a new card.



Apply for a Home Depot Consumer Card

Buy 4 or More, Get 15% Off

0 of 4 items

15% Off

Add 4 more to qualify

Shop This Offer

- Thumb lever locks in 6 in. increments to adjust pole length
- Threaded tip fits most roller frames and tools
- Sturdy and durable
- [View More Details](#)

Mount Pleasant Store

✓ 35 in stock Aisle 36, Bay SC1

Minimum length (ft.): 4

Maximum length (ft.): 8



Mount Ple... 10PM 10532 What can we help you find today?

Best Seller

9 in. Heavy Duty 5-Wire Paint Roller Frame

★★★★★ (145) Questions & Answers (7)

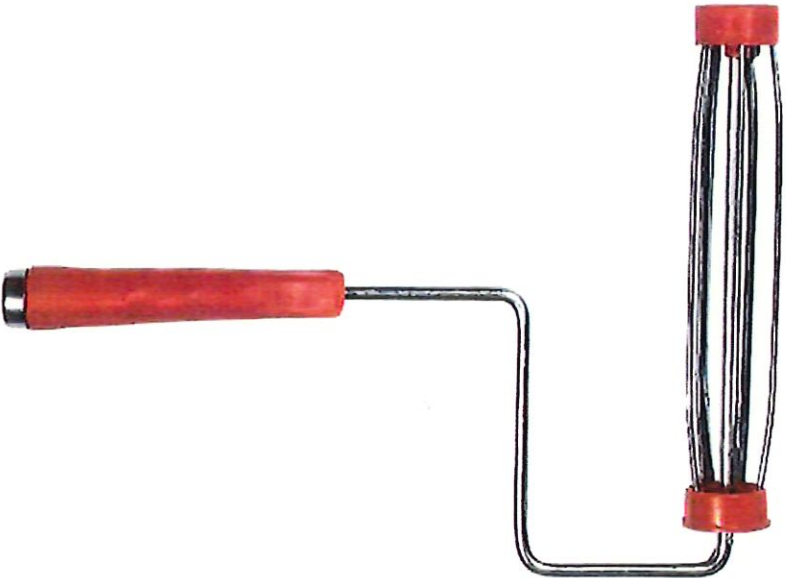

Hover Image to Zoom



\$4.48

- For use with all standard 9" paint roller covers
- 5-wire cage durably crafted with sturdy steel
- Threaded handle end is compatible with most extension poles
- [View More Details](#)

Mount Pleasant Store

✓ 300 in stock Aisle 36, Bay 008

Pickup at

Mount Pleasant

Delivering to 10532

Pickup
Today
300 in stock
FREE

Delivery
Tomorrow
304 available
FREE

[Check Nearby Stores](#)

[Delivery Details](#)

Order within 5 hrs 57 mins to get it by **Tomorrow**

Get it delivered Today for \$2.99. Schedule your delivery in checkout.

One-Time Purchase



Shop

9 in. Metal Paint Roller Tray

★★★★★ (991) Questions & Answers (3)

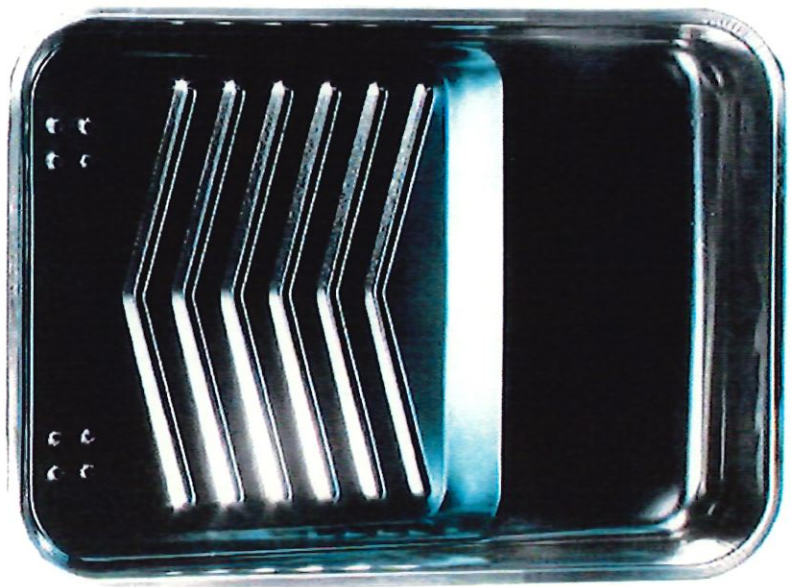

Hover Image to Zoom



\$3.98

- Designed for use with standard 9 in. roller covers and frames
- Made with solvent-resistant metal for durability
- Holds up to 1 quart paint or stain
- [View More Details](#)

Mount Pleasant Store

✓ 111 in stock Aisle 36, Bay 008

Pickup at
Mount Pleasant

Delivering to 10532

Pickup
Today
111 in stock
FREE

Delivery
Tomorrow
428 available
FREE

[Check Nearby Stores](#)

[Delivery Details](#)

Get it delivered Today for \$2.99. Schedule your delivery in checkout.

- 1 +

Add to Cart

Share Print

Pay in 4 interest-free payments on purchases of \$30-\$1,500 with **PayPal**. [Learn more](#)

Adjustments for 6000 Watt Generator in All Saved Models

August 13, 2025

Miscellaneous GAS 6,000 W
 Small Generator Sets

 Size Class:
5,001 - 10,000 W
 Weight:
 N/A

Configuration for GAS 6,000 W

 Horsepower **13.0 hp** Power Mode **Gasoline**
 Prime Output **6000.0 W**
Blue Book Rates

** FHWA Rate is equal to the monthly ownership cost divided by 176 plus the hourly estimated operating cost.

| | Ownership Costs | | | | Estimated Operating Costs | FHWA Rate** |
|---------------------------------------|---------------------|--------------------|--------------------|-------------------|---------------------------|-------------------|
| | Monthly | Weekly | Daily | Hourly | Hourly | Hourly |
| Published Rates | USD \$150.00 | USD \$42.00 | USD \$11.00 | USD \$2.00 | USD \$5.06 | USD \$5.91 |
| Adjustments | | | | | | |
| Region (100%) | - | - | - | - | | |
| Model Year (2018: 99%) | (USD \$1.50) | (USD \$0.42) | (USD \$0.11) | (USD \$0.02) | | |
| Adjusted Hourly Ownership Cost (100%) | - | - | - | - | | |
| Hourly Operating Cost (100%) | | | | | - | |
| Total: | USD \$148.50 | USD \$41.58 | USD \$10.89 | USD \$1.98 | USD \$5.06 | USD \$5.90 |

Non-Active Use Rates

| | Hourly |
|--------------|------------|
| Standby Rate | USD \$0.58 |
| Idling Rate | USD \$4.39 |

Rate Element Allocation

| Element | Percentage | Value |
|-----------------------------|------------|----------------|
| Depreciation (ownership) | 42.74% | USD \$64.10/mo |
| Overhaul (ownership) | 31.77% | USD \$47.65/mo |
| CFC (ownership) | 11.76% | USD \$17.64/mo |
| Indirect (ownership) | 13.74% | USD \$20.61/mo |
| Fuel (operating) @ USD 3.17 | 70.16% | USD \$3.55/hr |

Revised Date: 3rd quarter 2025

These are the most accurate rates for the selected Revision Date(s). However, due to more frequent online updates, these rates may not match Rental Rate Blue Book® Print. Visit the Cost Recovery Product Guide on our Help page for more information.

The equipment represented in this report has been exclusively prepared for (rdileonardo@verdeelectric.com)

Rental Rate Blue Book®

August 13, 2025

Miscellaneous COLD 2/1000G
 Pressure Washers Cold

 Size Class:
 To 1,500 psi
 Weight:
 300 lbs

Configuration for COLD 2/1000G

| | | | |
|-----------|--------------------|------------|-----------------|
| Flow Rate | 2.0 gal/min | Horsepower | 5.0 hp |
| Mounting | Portable | Power Mode | Gasoline |
| Pressure | 1500.0 psi | | |

Blue Book Rates

** FHWA Rate is equal to the monthly ownership cost divided by 176 plus the hourly estimated operating cost.

| | Ownership Costs | | | | Estimated Operating Costs Hourly | FHWA Rate** Hourly |
|---------------------------------------|---------------------|--------------------|--------------------|-------------------|-------------------------------------|-----------------------|
| | Monthly | Weekly | Daily | Hourly | | |
| Published Rates | USD \$315.00 | USD \$88.00 | USD \$22.00 | USD \$3.00 | USD \$2.87 | USD \$4.66 |
| Adjustments | | | | | | |
| Region (100%) | - | - | - | - | | |
| Model Year (2025: 100%) | - | - | - | - | | |
| Adjusted Hourly Ownership Cost (100%) | - | - | - | - | | |
| Hourly Operating Cost (100%) | | | | | - | |
| Total: | USD \$315.00 | USD \$88.00 | USD \$22.00 | USD \$3.00 | USD \$2.87 | USD \$4.66 |

Non-Active Use Rates

| | Hourly |
|--------------|------------|
| Standby Rate | USD \$0.61 |
| Idling Rate | USD \$2.49 |

Rate Element Allocation

| Element | Percentage | Value |
|-----------------------------|------------|-----------------|
| Depreciation (ownership) | 20.68% | USD \$65.15/mo |
| Overhaul (ownership) | 65.88% | USD \$207.52/mo |
| CFC (ownership) | 6.74% | USD \$21.23/mo |
| Indirect (ownership) | 6.7% | USD \$21.10/mo |
| Fuel (operating) @ USD 3.17 | 24.39% | USD \$0.70/hr |

Revised Date: 3rd quarter 2025

These are the most accurate rates for the selected Revision Date(s). However, due to more frequent online updates, these rates may not match Rental Rate Blue Book® Print. Visit the Cost Recovery Product Guide on our Help page for more information.

The equipment represented in this report has been exclusively prepared for (rdileonardo@verdeelectric.com)

Adjustments for Target Concrete Saw 65 HP in All Saved Models

September 25, 2025

Miscellaneous 14-36SPC
 Concrete Saws

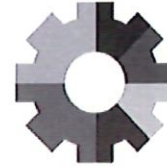
 Size Class:
37 hp & Over
 Weight:
 N/A

Configuration for 14-36SPC

| | | | |
|------------|-----------------|-----------------------|-----------------|
| Horsepower | 65.0 hp | Maximum Cutting Depth | 14.75 |
| Power Mode | Gasoline | Type | Concrete |

Blue Book Rates

** FHWA Rate is equal to the monthly ownership cost divided by 176 plus the hourly estimated operating cost.

| | Ownership Costs | | | | Estimated Operating Costs | FHWA Rate** |
|---------------------------------------|-----------------------|-----------------------|---------------------|--------------------|---------------------------|--------------------|
| | Monthly | Weekly | Daily | Hourly | Hourly | Hourly |
| Published Rates | USD \$5,415.00 | USD \$1,515.00 | USD \$380.00 | USD \$57.00 | USD \$31.28 | USD \$62.05 |
| Adjustments | | | | | | |
| Region (New York: 108%) | USD \$433.20 | USD \$121.20 | USD \$30.40 | USD \$4.56 | | |
| Model Year (2004: 87.41%) | (USD \$736.01) | (USD \$205.92) | (USD \$51.65) | (USD \$7.75) | | |
| Adjusted Hourly Ownership Cost (100%) | - | - | - | - | | |
| Hourly Operating Cost (100%) | | | | | - | |
| Total: | USD \$5,112.19 | USD \$1,430.28 | USD \$358.75 | USD \$53.81 | USD \$31.28 | USD \$60.33 |

Non-Active Use Rates

| | Hourly |
|--------------|-------------|
| Standby Rate | USD \$6.18 |
| Idling Rate | USD \$45.16 |

Rate Element Allocation

| Element | Percentage | Value |
|-----------------------------|------------|-------------------|
| Depreciation (ownership) | 10.57% | USD \$572.21/mo |
| Overhaul (ownership) | 78.73% | USD \$4,263.09/mo |
| CFC (ownership) | 4.68% | USD \$253.42/mo |
| Indirect (ownership) | 6.03% | USD \$326.27/mo |
| Fuel (operating) @ USD 3.17 | 51.5% | USD \$16.11/hr |

Revised Date: 3rd quarter 2025

These are the most accurate rates for the selected Revision Date(s). However, due to more frequent online updates, these rates may not match Rental Rate Blue Book® Print. Visit the Cost Recovery Product Guide on our Help page for more information.

The equipment represented in this report has been exclusively prepared for (rdleonardo@verdeelectric.com)

Adjustments for #163 - 2022 Chevy Silverado 2500 Pick up Truck in All Saved Models

March 4, 2026

Chevrolet SILVERADO 2500HD 4X4 DIESEL
 Light Duty Trucks

 Size Class:
3
 Weight:
 N/A

Configuration for SILVERADO 2500HD 4X4 DIESEL

| | | | |
|-----------------------------|---------------------|-----------|---------------------|
| Power Mode | Diesel | Wheelbase | 149.4 Inches |
| Gross Vehicle Weight Rating | 11200 Pounds | | |

Blue Book Rates

** FHWA Rate is equal to the monthly ownership cost divided by 176 plus the hourly estimated operating cost.

| | Ownership Costs | | | | Estimated Operating Costs Hourly USD \$19.35 | FHWA Rate** Hourly USD \$41.11 |
|---------------------------------------|-----------------------|-----------------------|---------------------|--------------------|--|--------------------------------------|
| | Monthly | Weekly | Daily | Hourly | | |
| Published Rates | USD \$3,830.00 | USD \$1,075.00 | USD \$270.00 | USD \$41.00 | | |
| Adjustments | | | | | | |
| Region (100%) | - | - | - | - | | |
| Model Year (2022: 97.06%) | (USD \$112.73) | (USD \$31.64) | (USD \$7.95) | (USD \$1.21) | | |
| Adjusted Hourly Ownership Cost (100%) | - | - | - | - | | |
| Hourly Operating Cost (100%) | | | | | - | |
| Total: | USD \$3,717.27 | USD \$1,043.36 | USD \$262.05 | USD \$39.79 | USD \$19.35 | USD \$40.47 |

Non-Active Use Rates

| | Hourly |
|--------------|-------------|
| Standby Rate | USD \$12.74 |
| Idling Rate | USD \$28.85 |

Rate Element Allocation

| Element | Percentage | Value |
|-----------------------------|------------|-------------------|
| Depreciation (ownership) | 27.57% | USD \$1,055.91/mo |
| Overhaul (ownership) | 39.7% | USD \$1,520.38/mo |
| CFC (ownership) | 16.48% | USD \$631.24/mo |
| Indirect (ownership) | 16.25% | USD \$622.46/mo |
| Fuel (operating) @ USD 3.83 | 39.95% | USD \$7.73/hr |

Revised Date: 1st quarter 2026

These are the most accurate rates for the selected Revision Date(s). However, due to more frequent online updates, these rates may not match Rental Rate Blue Book® Print. Visit the Cost Recovery Product Guide on our Help page for more information.

The equipment represented in this report has been exclusively prepared for (rdileonardo@verdeelectric.com)

Adjustments for Rack/Box Truck 156 in All Saved Models
Miscellaneous 6X6 70KGWV DSL
 On-Highway Truck Tractors

 Size Class:
60,001 lbs & Over
 Weight:
N/A

Configuration for 6X6 70KGWV DSL

| | | | |
|------------------------------|--------------------|------------|-----------------|
| Axle Configuration | 6X6 | Horsepower | 450.0 hp |
| Maximum Gross Vehicle Weight | 70000.0 lbs | Power Mode | Diesel |

Blue Book Rates

** FHWA Rate is equal to the monthly ownership cost divided by 176 plus the hourly estimated operating cost.

| | Ownership Costs | | | | Estimated Operating Costs Hourly USD \$61.38 | FHWA Rate** Hourly USD \$86.75 |
|---------------------------------------|-----------------------|-----------------------|---------------------|--------------------|--|--------------------------------------|
| | Monthly | Weekly | Daily | Hourly | | |
| Published Rates | USD \$4,465.00 | USD \$1,250.00 | USD \$315.00 | USD \$47.00 | | |
| Adjustments | | | | | | |
| Region (New York: 104%) | USD \$178.60 | USD \$50.00 | USD \$12.60 | USD \$1.88 | | |
| Model Year (2023: 99.94%) | (USD \$2.63) | (USD \$0.74) | (USD \$0.19) | (USD \$0.03) | | |
| Adjusted Hourly Ownership Cost (100%) | - | - | - | - | | |
| Hourly Operating Cost (100%) | | | | | - | |
| Total: | USD \$4,640.97 | USD \$1,299.26 | USD \$327.41 | USD \$48.85 | USD \$61.38 | USD \$87.75 |

Non-Active Use Rates

| | Hourly |
|--------------|-------------|
| Standby Rate | USD \$16.50 |
| Idling Rate | USD \$68.61 |

Rate Element Allocation

| Element | Percentage | Value |
|-----------------------------|------------|-------------------|
| Depreciation (ownership) | 42.27% | USD \$1,887.24/mo |
| Overhaul (ownership) | 37.42% | USD \$1,670.85/mo |
| CFC (ownership) | 9.36% | USD \$418.00/mo |
| Indirect (ownership) | 10.95% | USD \$488.91/mo |
| Fuel (operating) @ USD 3.83 | 68.82% | USD \$42.24/hr |

Revised Date: 1st quarter 2026

These are the most accurate rates for the selected Revision Date(s). However, due to more frequent online updates, these rates may not match Rental Rate Blue Book® Print. Visit the Cost Recovery Product Guide on our Help page for more information.

The equipment represented in this report has been exclusively prepared for (rdleonardo@verdeelectric.com)

Adjustments for Rack/Box Truck 156 in All Saved Models

March 4, 2026

Miscellaneous 6X6 70KGWV DSL
 On-Highway Truck Tractors

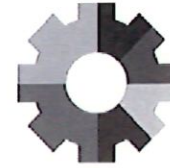
 Size Class:
60,001 lbs & Over
 Weight:
N/A

Configuration for 6X6 70KGWV DSL

| | | | |
|------------------------------|--------------------|------------|-----------------|
| Axle Configuration | 6X6 | Horsepower | 450.0 hp |
| Maximum Gross Vehicle Weight | 70000.0 lbs | Power Mode | Diesel |

Blue Book Rates

** FHWA Rate is equal to the monthly ownership cost divided by 176 plus the hourly estimated operating cost.

| | Ownership Costs | | | | Estimated Operating Costs | FHWA Rate** |
|---------------------------------------|-----------------------|-----------------------|---------------------|--------------------|---------------------------|--------------------|
| | Monthly | Weekly | Daily | Hourly | Hourly | Hourly |
| Published Rates | USD \$4,465.00 | USD \$1,250.00 | USD \$315.00 | USD \$47.00 | USD \$61.38 | USD \$86.75 |
| Adjustments | | | | | | |
| Region (New York: 104%) | USD \$178.60 | USD \$50.00 | USD \$12.60 | USD \$1.88 | | |
| Model Year (2023: 99.94%) | (USD \$2.63) | (USD \$0.74) | (USD \$0.19) | (USD \$0.03) | | |
| Adjusted Hourly Ownership Cost (100%) | - | - | - | - | | |
| Hourly Operating Cost (100%) | | | | | - | |
| Total: | USD \$4,640.97 | USD \$1,299.26 | USD \$327.41 | USD \$48.85 | USD \$61.38 | USD \$87.75 |

Non-Active Use Rates

| | |
|--------------|---------------|
| | Hourly |
| Standby Rate | USD \$16.50 |
| Idling Rate | USD \$68.61 |

Rate Element Allocation

| Element | Percentage | Value |
|-----------------------------|------------|-------------------|
| Depreciation (ownership) | 42.27% | USD \$1,887.24/mo |
| Overhaul (ownership) | 37.42% | USD \$1,670.85/mo |
| CFC (ownership) | 9.36% | USD \$418.00/mo |
| Indirect (ownership) | 10.95% | USD \$488.91/mo |
| Fuel (operating) @ USD 3.83 | 68.82% | USD \$42.24/hr |

Revised Date: 1st quarter 2026

These are the most accurate rates for the selected Revision Date(s). However, due to more frequent online updates, these rates may not match Rental Rate Blue Book® Print. Visit the Cost Recovery Product Guide on our Help page for more information.

The equipment represented in this report has been exclusively prepared for (rdleonardo@verdeelectric.com)



Insurance | Risk Management | Consulting

30 Century Hill Drive, Suite 200
Latham, NY 12110
USA

518-869-3535
www.ajg.com

January 26, 2026

Verde Electric Maintenance Corporation.
89 Edison Avenue
Mount Vernon, NY 10550

**Re: Workers Compensation Experience Modifications
Verde Electric Maintenance Corporation.**

Dear Tricia:

Please allow this letter to acknowledge and confirm the Workers Compensation Experience Modification for the above.

The EMR's are as follows:

| <u>Effective Year</u> | <u>Experience Modification</u> |
|-----------------------|--------------------------------|
| 10/30/25 to 10/30/26 | 1.00 |

We trust you will find the enclosed in order but should you have any questions please contact our office.

Sincerely,

Julie Kaiser

Julie Kaiser
Client Service Manager



Insurance | Risk Management | Consulting

March 4, 2026

New York State Department of Transportation
50 Wolf Road
Albany, NY 12232

Re: Insured - Verde Electric Corp - 89 Edison Avenue, Mount Vernon, NY 10550

General Liability/ Umbrella Insurance Rate Calculation Based on Sales:

| | | |
|---|----------------------------|-----------------------|
| General Liability (per \$100 of payroll) | \$30.65 | See below for support |
| Lead Umbrella (per \$100 of payroll) | \$5.50 | See below for support |
| First Umbrella (per \$100 of payroll) | \$4.00 | See below for support |
| Second Umbrella (per \$100 of payroll) | \$3.50 | See below for support |
| Total | \$43.65 \$40.15 | |
| Per \$100 of payroll | | |
| | | |
| Verde Electric GL & Umbrella Rate | 43.65% 40.15% | |

General Liability

Insuring Company: Traveler Indemnity Company.

AM. Best Rating: A++XV (Admitted)

Policy Number: VTC2KCO3X459385IND25

Policy Expires: 10/31/2026

Limit of Liability:

General Aggregate: \$4,000,000

Products Completed Operations Aggregate: \$4,000,000

Personal & Advt. Injury: \$2,000,000

Each Occurrence: \$ 2,000,000

Damage to Rented Premise: \$300,000

Rate- \$30.65 per \$100 of Payroll



Insurance | Risk Management | Consulting

Excess Umbrella Liability

Insuring Company: Starr Indemnity & Liability Company Company.

AM. Best Rating: A++XV (Admitted)

Policy Number: 1100588039251

Policy Expires: 10/31/2026

Limit of Liability:

General Aggregate: \$3,000,000

Each Occurrence: \$3,000,000

Rate- \$5.50 per \$100 of Payroll

Excess Umbrella Second

Insuring Company: Berkley Casualty Company

AM. Best Rating: A+XV (Admitted)

Policy Number: BCS880013440

Policy Expires: 10/31/2026

Limit of Liability:

General Aggregate: \$7,000,000

Each Occurrence: \$7,000,000

Rate- \$4.00 per \$100 of Payroll

Excess Umbrella Third

Insuring Company: Zurich Insurance Company & Liberty Insurance Underwriting

AM. Best Rating: A+XV (Admitted) and A XV (Admitted)

Policy Number: A E C 7 1 3 0 5 7 0 - 0 3 and 1 0 0 0 5 7 0 2 1 6 0 2

Policy Expires: 10/31/2026

Limit of Liability:

General Aggregate: \$10,000,000



Insurance | Risk Management | Consulting

Each Occurrence: \$10,000,000

Rate- \$3.50 per \$100 of Payroll

Workers Compensation

Insuring Company: Charter Oak Fire Ins. Co. (Travelers)

AM. Best Rating: A++XV

Policy Number: UB4X4902572525H

Policy Expires: 10/31/2026

Limit of Liability:

Each Accident: Statutory Disease

Policy Limit: Statutory

Disease: Each Employee: Statutory

Exposure: Electrical Wiring Rate: \$12.38 per \$100 of Payroll: Conduit Rate - \$16.74 per \$100

Average Rate: \$14.56 per \$100 of Payroll (See Support Below)

| | Estimated Payroll | Rate per \$100 | Premium |
|-------------------|-----------------------|----------------|---------------------|
| Electrical Wiring | \$1,100,000.00 | 12.38% | \$136,111.80 |
| Conduit | \$1,300,909.00 | 16.74% | \$217,623.90 |
| Total: | \$2,400,000.00 | | \$353,735.70 |
| | | 14.56% | Blended Rate |

If you would like to speak with me directly please feel free to contact me. My email address is David_Brockmann@ajg.com; my office phone number is 518-533-6898 and my mobile phone number is 518- 330-1743.

David Brockmann

David Brockmann, Jr.
Area Vice President
Director of Construction Services
Arthur J. Gallagher Risk Management Services

NEW YORK STATE DEPARTMENT OF TRANSPORTATION
COST ANALYSIS WORKSHEET (9/22)

Contract D# 036472

Change Order # 001

Field Change Payment #

CO Item Qty 720

Section 1 - Existing Contract Item

Use the Item Analysis Report and CONR 22 Composite Report in BI to fill out the below information. Follow Added Work Cost Analysis Decision Flow Chart.

Item Spec No

Unit Bid Price

Bid Qty

Current Contract Qty

Major Item

Minor Item

75% Threshold

Renegotiation Threshold

125% Threshold

(200% and \$5,000 over original contract amount)

High Bid Item (over 125%) Yes No

Section 2 - New Contract Item or Continuation of Existing Item

New Item Spec No 950.04A

Renegotiated Qty 720

Contractor Quoted Unit Price \$2,491.57

Method Chosen:

- Original Bid Price Acceptable?
- Contractor agrees to work at the Original Contract Bid Price adjusted for documented changes in material costs, equipment rates, mobilization, and/or site conditions, and bid price is reasonable compensation for the quantity of added work: include letter from contractor, and supporting documentation for adjustments (need price analysis) on CO Header
- Weighted Average Price (WAP) Comparison (must have at least 3 contracts)

Pay Item Catalog Date Range to

PIC Qty Range to N/A

Regional WAP Statewide WAP

Printout of PIC w/ Qty Range, dates, prices attached?

- Comparison to Average of 3 Lowest Bidders (on contract, not item)

Average Price \$0.00

Bidder 1

Bidder 2

Bidder 3

Printout of 3 Lowest Bidders on the Contract attached?

- Price Analysis

MURK 26/27 Price Analysis Worksheet attached and all documentation attached?

- Force Account Work (FAW)

FE (Force Estimate) Estimate of Labor, Materials, and Equipment work up included?

FAW (Final) Included with all MURK forms and documentation attached?

Project Conditions/Variance Explanation attached?

Signature



Date

Apr 7, 2026

950.04A - STAMPED/IMPRINTED COLORED CONCRETE SIDEWALK

950.0401A - COLORED CONCRETE FOR TYPE 1 CURB RAMP

950.0402A - COLORED CONCRETE FOR TYPE 9 CURB RAMP

950.0403A - COLORED CONCRETE FOR TYPE 11 CURB RAMP

DESCRIPTION

The work shall consist of furnishing and installing colored, imprinted, or colored and imprinted Portland cement concrete sidewalks as shown on the contract documents and as directed by the Engineer.

MATERIALS

The following sections of the standard specifications shall apply:

Sidewalks, Driveways, Bicycle Paths and Vegetation Control Strips 608-2

The following ASTM Specifications shall apply:

Standard Specification for Pigments for Integrally Colored Concrete C979

Integral Color Concrete Admixture

The color shall be as indicated in the City of Newburgh Standard Details and Notes, approved June 19, 2025, U28 Charcoal or Approved Equal. Unless otherwise approved, the pigment shall be from the same batch or lot for each color used.

All colored and/or colored imprinted concrete shall be sealed with Butterfield Clear-Guard Pro 350 Cure and Seal mixed with clear guard Slip-Resistant additive for increased slip resistance or approved equal.

Color admixtures for integrally colored concrete shall be:

- certified by the manufacturer as meeting the requirements of ASTM C979. The Contractor shall provide the manufacturer's certification verifying that the colored concrete admixture meets ASTM C979.
- added to the concrete mix per manufacturer's recommendations at a dosage rate to achieve the color specified in the contract documents; the manufacturer's recommended maximum dosage rate shall not be exceeded.
- packaged so that each dose is the proper dose for 1 cubic yard of concrete.

Imprinted Concrete

Use imprinting tools capable of imprinting the surface of the concrete with a uniform and aligned pattern and/or texture. Use a clear release agent as specified by the imprinting tool manufacturer. These materials shall be approved before their use. Formliners shall be composed of elastomeric urethane, polyvinyl chloride (PVC) or ABS material designed for their intended shape and number of reuses to achieve the desired pattern. Formliners shall not be worn, damaged, compromise the desired patterning effect, or cause damage to the concrete during form removal.

950.04A - STAMPED COLORED CONCRETE SIDEWALK
950.0401A - COLORED CONCRETE FOR TYPE 1 CURB RAMP
950.0402A - COLORED CONCRETE FOR TYPE 9 CURB RAMP
950.0403A - COLORED CONCRETE FOR TYPE 11 CURB RAMP

Colored Concrete

Colored Concrete shall receive a broom finish and receive the same sealer and non-slip additive as required by the City of Newburgh Specification and as recommended by the manufacturer at all pedestrian facility curb ramps

Color Matching Joint Material

When specified for any location, use a color-matched caulking compound designed for joint sealing.

CONSTRUCTION DETAILS

The following sections of the standard specifications shall apply:

Sidewalks, Driveways, Bicycle Paths and Vegetation Control Strips 608-3
with the following modifications:

City of Newburgh Standard Detail – Approved June 19, 2025, apply.

Contractor Qualifications:

Per §105-02, The Contractor shall have sufficient skill and experience to properly perform colored and imprinted concrete work.

Test Panels:

The Contractor shall construct job site test panel(s) as follows:

The test panel(s) shall:

- be at least 3 feet x 3 feet,
- be constructed at a selected location,
- include one job site test panel for review and approval for each individual pattern, color, or color and pattern specified in the contract documents and
- not be incorporated into the work and be removed when ordered.

Additional test panels may be requested as needed to receive approval. The Contractor must receive approval of the test panel(s) before preparing the final-colored concrete batch. The permanent work shall be produced using the same methods used in the approved test panel and consistent with the appearance of the approved test panel(s).

950.04A – STAMPED COLORED CONCRETE SIDEWALK

950.0401A – COLORED CONCRETE FOR TYPE 1 CURB RAMP

950.0402A – COLORED CONCRETE FOR TYPE 9 CURB RAMP

950.0403A - COLORED CONCRETE FOR TYPE 11 CURB RAMP

Test Panel Approval: The Contractor shall notify the Engineer:

- one week before producing the test panel(s), and
- when the test panel(s) is in place and ready for review.

After being notified, the Department will have one week to review the test panel and convey to the Contractor whether the test panel(s) has been approved.

Color Concrete Admixture

Add the integral color admixture at the manufacturer's recommended dosage rate. This rate is to remain constant for all batches of concrete produced. Before placing concrete, the Contractor shall protect adjacent surfaces and structures from spatters. Once a portion of the batch has been placed, no additional water shall be added to the remaining batch.

To integrally color the concrete, introduce the color additive into the mixer drum as the manufacturer recommends. The quantity of concrete being delivered shall be at least one-third the capacity of the mixer drum. Batch the concrete in full cubic yard increments.

Architectural Patterned and Textured Concrete: The Contractor shall:

- screed concrete to the finished grade and apply the release agent evenly over the entire imprinting tool. Using methods recommended by the manufacturer, apply pre-approved imprinting tools to the surface while the concrete is still plastic. The requirement for a lightly broomed surface is waived.
- unless otherwise specified, score or saw cut the surface to a minimum depth of $\frac{1}{4}$ the thickness of the slab at intervals that are consistent with the architectural pattern or as indicated in the contract documents. If the saw cut option is used, the Contractor shall be responsible for performing the saw cut operation at such time as to minimize the possibility of spalling and/or cracking.
- tool the edges, joints and scored areas in a manner consistent with the imprinting pattern.

Within 24 hours, remove release agent with pressure wash and apply the pre-approved sealer, and slip resistant additive recommended by the coloring manufacturer, at a rate consistent with the manufacturer's specifications.

950.04A – STAMPED COLORED CONCRETE SIDEWALK

950.0401A – COLORED CONCRETE FOR TYPE 1 CURB RAMP

950.0402A – COLORED CONCRETE FOR TYPE 9 CURB RAMP

950.0403A - COLORED CONCRETE FOR TYPE 11 CURB RAMP

Color Matching Joint Material

Install pre-molded resilient joint filler (§705-07) where the sidewalk line intersects a building, walk, permanent structure, or other designated location to within 1 inch of the top of the slab.

Caulk the top 1 inch of the joint with color-matched caulking compound Color Matching Joint Material SikaSil – 728 SL Charcoal Gray or Approved Equal.

METHOD OF MEASUREMENT

The work will be measured as the number of cubic yards, to the nearest 0.1 cubic yard of colored, imprinted, or colored and imprinted Portland cement concrete sidewalk installed.

Pedestrian facility ADA Ramps will be measured as the number of each completed of colored Portland cement installed.

BASIS OF PAYMENT

The unit bid price per cubic yard of colored, imprinted, or colored and imprinted Portland cement concrete sidewalk furnished and installed shall include the cost of all labor, equipment, and materials necessary to satisfactorily complete the work.

The unit bid price per each ADA Ramp colored, Portland cement concrete ADA Ramp furnished and installed shall include the cost of all labor, equipment, and materials necessary to satisfactorily complete the work.

The cost of construction and removal of the test panel(s) will be included in the price bid for the specified item(s).

Payment will be made under:

| ITEM NUMBER | ITEM DESCRIPTION | UNIT |
|--------------------|--|-------------|
| 950.04A | Stamped Colored Concrete Sidewalk | CY |
| 950.0401A | Colored Concrete for Type 1 Curb Ramp | EA |
| 950.0402A | Colored Concrete for Type 9 Curb Ramp | EA |
| 950.0403A | Colored Concrete for Type 11 Curb Ramp | EA |



89 Edison Avenue • Mt. Vernon, New York 10550
Phone 914-664-7000 • Facsimile 914-668-7997

March 25, 2026

WSP Field Office/Broadway TSP
1 Corwin Court, Room 102
Newburgh, NY 10550
Attn: Arlisa McGrath, EIC

RE: Contract Pins 8005.26 and 8758.75
Broadway Pedestrian and Traffic Signal Improvements
VEMC Job #8510 and 8530
Item No. 950.0401 - Colored Concrete for Type 1 Curb Ramps with Pro350 Sealer and Slip Resistance
Item No. 950.0402 - Colored Concrete for Type 9 Curb Ramps with Pro350 Sealer and Slip Resistance
Item No. 950.0403 - Colored Concrete for Type 11 Curb Ramps with Pro350 Sealer and Slip Resistance
Letter of Concurrence

Dear Arlisa:

Verde Electric Maintenance Corp. accepts the agreed price for:

| | |
|-------------------|--|
| Item No.: | 950.0401 |
| Item Description: | Colored Concrete for Type 1 Curb Ramps with Pro350 Sealer and Slip Resistance |
| Quantity: | 46ea |
| Unit Price: | \$9,200.46 |
| Total Extension: | \$423,221.16 |
| Item No.: | 950.0402 |
| Item Description: | Colored Concrete for Type 9 Curb Ramps with Pro350 Sealer and Slip Resistance |
| Quantity: | 2ea |
| Unit Price: | \$10,633.72 |
| Total Extension: | \$21,267.44 |
| Item No.: | 950.0403 |
| Item Description: | Colored Concrete for Type 11 Curb Ramps with Pro350 Sealer and Slip Resistance |
| Quantity: | 2ea |
| Unit Price: | \$9,757.19 |
| Total Extension: | \$19,514.38 |

Please do not hesitate to contact me if you have any questions.

Very truly yours,
Verde Electric Maintenance Corp.

Robert Craig
Vice President

NEW YORK STATE DEPARTMENT OF TRANSPORTATION

Agreed Price Worksheet - Prime Contractor

Contract: 8758.75 Item No.: 950.0401 Quantity: 46.00 Units: EA

Item Description : Colored Concrete for Type 1 Curb Ramps w/ Pro350 Sealer & Slip Resistant

(A) LABOR

| Trade | Reg Hours | Wage Rate | Cost | Fringe Hours | Fringe Rate | Cost |
|-------------------------------|-----------|-----------|-------------|--------------|-------------|-------------|
| 137 Operator Foreman | 315.00 | \$ 65.26 | \$20,556.90 | 315.00 | \$ 50.46 | \$15,894.90 |
| 60 Laborer Group 2 | 946.00 | \$ 50.71 | \$47,971.66 | 946.00 | \$ 34.82 | \$32,939.72 |
| 60 ACI Concrete Finisher Grp1 | 315.00 | \$ 56.27 | \$17,725.05 | 315.00 | \$ 35.14 | \$11,069.10 |
| 137 Operator Journeyman | 121.00 | \$ 62.07 | \$ 7,510.47 | 121.00 | \$ 50.14 | \$ 6,066.94 |
| | | | | | | |
| | | | | | | |
| | | | | | | |
| | | | | | | |

Wages \$93,764.08 Fringes \$65,970.66

If Fringes are paid directly to employee via cash or check, Enter value here:

\$ 0.00

Worker's Compensation Rate (%):

14.56 %

| | |
|-----------------------------|-----------------------|
| Total of Wages and Fringes: | 159,734.74 |
| Workers Compensation: | \$13,652.05 |
| Standard Labor Markup: | \$11,720.51 |
| Fringe Benefit Markup: | \$ 0.00 |
| Labor Total: | 185,107.300048 |

(The Contractor shall submit an insurance policy declaration / rate page from its insurer to validate the Workers Comp insurance rate based on an EMR of 1.0.)

(B) MATERIALS

| Description | Units | # of Units | Cost/Unit | Cost | Description | Units | # of Units | Cost/Unit | Cost |
|---------------------|-------|------------|-----------|-------------|------------------|-------|------------|-------------|-------------|
| Colored Concrete | CY | 46.00 | \$301.59 | \$13,873.14 | HC Tiles | EA | 92.00 | \$133.32 | \$12,265.44 |
| Pro350 Sealer | PAIL | 2.00 | \$289.17 | \$578.34 | Granite Curb | LS | 1.00 | \$30,387.81 | \$30,387.85 |
| Slip-Resist Additiv | BOX | 2.00 | \$21.47 | \$42.94 | Class A Concrete | CY | 11.00 | \$171.00 | \$1,881.00 |
| Paint Supplies | LS | 1.00 | \$170.00 | \$170.00 | Asphalt | TON | 30.00 | \$91.00 | \$2,730.00 |

Materials Total: \$61,928.71

(C) EQUIPMENT

| Description | Hours | FHWA Rate | Cost | Description | Hours | FHWA Rate | Cost |
|---------------|--------|-----------|-------------|-------------|-------|-----------|------|
| Pickup Truck | 315.00 | \$41.11 | \$12,949.65 | | | | |
| Box Truck | 315.00 | \$86.75 | \$27,326.25 | | | | |
| Rack Truck | 315.00 | \$86.75 | \$27,326.25 | | | | |
| Komatsu PC-78 | 121.00 | \$55.16 | \$6,674.36 | | | | |

Equipment Total: \$74,276.51

(D) SERVICES

| Description / Type | # of Units | Cost / Unit | Cost | Description / Type | # of Units | Cost / Unit | Cost |
|--------------------|------------|-------------|------|--------------------|------------|-------------|------|
| | | | | | | | |
| | | | | | | | |

Services Total:

(E) OVERHEAD & PROFIT

| | | | | | |
|--------------------------------------|---------------|---------------|-------|------|--------------|
| Labor, Materials, & Equipment Total: | \$ 321,312.52 | OH & Profit % | 20.00 | Cost | \$ 64,262.50 |
| Services: | | | | | \$ 0.00 |

Overhead & Profit Total: \$64,262.50

(F) INSURANCE

Enter rate here if based on payroll

Payroll Based Cost Basis

40.15 %

Enter rate here if based on sales

Sales Based Cost Basis

\$ 0.00

Insurance Total: \$37,646.28

Item Total: \$ 423,221.30

Unit Price: \$ 9,200.46 per EA

| | | | | | |
|-----------------------|--|---------|---------------------------|-----------------------|--------|
| Robert Craig | Robert Craig <small>Digitally signed by Robert Craig Date: 2026.03.04 09:48:42 EST '07</small> | 3-12-26 | Arlisa McGrath | <i>Arlisa McGrath</i> | 4/9/26 |
| Contractor's Rep Name | Signature | Date | Engineer-in-Charge's Name | Signature | Date |

VERDE ELECTRIC CORP LABOR RATE BREAKDOWN

EFFECTIVE DATES:

FROM: 3/4/2025
 TO: 3/3/2026

TRADE CLASSIFICATION: OPERATORS OS FOREMAN

UNION: OPERATING ENGINEERS
 LOCAL NO: 137

| | | Straight Time | Overtime & Saturday | Sunday |
|---|-----------------------------------|---------------|---------------------|-----------|
| 1 HOURLY RATE | | \$ 65.26 | \$ 97.89 | \$ 130.52 |
| 2 FRINGES: | | RATE | | |
| | Welfare | \$21.40 | \$ 21.40 | \$ 21.40 |
| | Vacation | \$3.20 | \$ 3.20 | \$ 3.20 |
| | Savings/PSL | \$1.10 | \$ 1.10 | \$ 1.10 |
| | Pension | \$5.18 | \$ 5.18 | \$ 5.18 |
| | Apprenticeship | \$1.30 | \$ 1.30 | \$ 1.30 |
| | National Training | \$0.10 | \$ 0.10 | \$ 0.10 |
| | Annuity | \$8.50 | \$ 8.50 | \$ 8.50 |
| | IAF | \$0.50 | \$ 0.50 | \$ 0.50 |
| | Supplemental Dues | 3.75% | \$ 2.45 | \$ 3.67 |
| | PAC | \$0.05 | \$ 0.05 | \$ 0.05 |
| | LMCT | \$1.00 | \$ 1.00 | \$ 1.00 |
| ** | Holiday | \$5.68 | \$ 5.68 | \$ 5.68 |
| TOTAL FRINGES: | | \$ 50.46 | \$ 51.68 | \$ 52.90 |
| 3 PAYROLL TAXES & INSURANCE | | RATE | | |
| | FICA (Social Security & Medicare) | 7.65% | \$ 4.99 | \$ 7.49 |
| | Federal Unemployment | 0.60% | \$ 0.39 | \$ 0.59 |
| | Metro Tax | 0.34% | \$ 0.22 | \$ 0.33 |
| | New York Unemployment | 8.33% | \$ 5.44 | \$ 8.15 |
| | Workers Comp | 7.80% | \$ 5.09 | \$ 5.09 |
| | General Liability | 15.50% | \$ 10.12 | \$ 15.17 |
| TOTAL PAYROLL TAXES & INSURANCE: | | | \$ 26.25 | \$ 36.83 |
| 4 TOTAL LABOR RATE, FRINGES, TAXES & INSURANCE | | | \$ 141.96 | \$ 186.40 |
| | | | \$ 230.83 | |

** Holiday computed as 80 hour cost divided by 1,920 (est. 48 week work year)

VERDE ELECTRIC CORP LABOR RATE BREAKDOWN

EFFECTIVE DATES:

FROM: 3/30/2025
 TO: 3/28/2026

TRADE CLASSIFICATION:

GROUP II

UNION:

HVY, HWY, UTILITY
 LOCAL NO: 60

| | | Straight Time | Overtime & Saturday | Sunday |
|--|-------------|---------------|------------------------|-----------|
| 1 HOURLY RATE | | \$ 50.71 | \$ 76.07 | \$ 101.42 |
| 2 FRINGES: | | | | |
| | RATE | | | |
| Welfare | \$10.63 | \$ 10.63 | \$ 10.63 | \$ 10.63 |
| Pension | \$11.15 | \$ 11.15 | \$ 11.15 | \$ 11.15 |
| Annuity | \$6.00 | \$ 6.00 | \$ 6.00 | \$ 6.00 |
| Apprentice & Training | \$1.10 | \$ 1.10 | \$ 1.10 | \$ 1.10 |
| Labor Management | \$0.95 | \$ 0.95 | \$ 0.95 | \$ 0.95 |
| LECET | \$0.15 | \$ 0.15 | \$ 0.15 | \$ 0.15 |
| NY Health and Safety | \$0.10 | \$ 0.10 | \$ 0.10 | \$ 0.10 |
| IAF | \$0.50 | \$ 0.50 | \$ 0.50 | \$ 0.50 |
| ** Holiday | \$4.24 | \$ 4.24 | \$ 4.24 | \$ 4.24 |
| TOTAL FRINGES: | | \$ 34.82 | \$ 34.82 | \$ 34.82 |
| 3 PAYROLL TAXES & INSURANCE | | | | |
| | RATE | | | |
| FICA (Social Security & Medicare) | 7.65% | \$ 3.88 | \$ 5.82 | \$ 7.76 |
| Federal Unemployment | 0.60% | \$ 0.30 | \$ 0.46 | \$ 0.61 |
| Metro Tax | 0.34% | \$ 0.17 | \$ 0.26 | \$ 0.34 |
| New York Unemployment | 8.33% | \$ 4.22 | \$ 6.33 | \$ 8.44 |
| Workers Comp | 7.80% | \$ 3.96 | \$ 3.96 | \$ 3.96 |
| General Liability | 15.50% | \$ 7.86 | \$ 11.79 | \$ 15.72 |
| TOTAL PAYROLL TAXES & INSURANCE: | | \$ 20.39 | \$ 28.61 | \$ 36.83 |
| 4 TOTAL LABOR RATE, TAXES & INSURANCE | | \$ 105.92 | \$ 139.49 | \$ 173.07 |

** Holiday computed as 80 hour cost divided by 1,920 (est. 48 week work year)

VERDE ELECTRIC CORP LABOR RATE BREAKDOWN

EFFECTIVE DATES:

FROM: 3/30/2025
 TO: 3/28/2026

TRADE CLASSIFICATION:

GROUP I

UNION:

HVY, HWY, UTILITY

LOCAL NO:

60

Concrete Finisher

| | | Straight Time | Overtime & Saturday | Sunday |
|--|-------------|---------------|------------------------|-----------|
| 1 HOURLY RATE | | \$ 56.27 | \$ 84.41 | \$ 112.54 |
| 2 FRINGES: | | | | |
| | RATE | | | |
| Welfare | \$10.63 | \$ 10.63 | \$ 10.63 | \$ 10.63 |
| Pension | \$11.15 | \$ 11.15 | \$ 11.15 | \$ 11.15 |
| Annuity | \$6.00 | \$ 6.00 | \$ 6.00 | \$ 6.00 |
| Apprentice & Training | \$1.10 | \$ 1.10 | \$ 1.10 | \$ 1.10 |
| Labor Management | \$0.95 | \$ 0.95 | \$ 0.95 | \$ 0.95 |
| LECET | \$0.15 | \$ 0.15 | \$ 0.15 | \$ 0.15 |
| NY Health and Safety | \$0.10 | \$ 0.10 | \$ 0.10 | \$ 0.10 |
| IAF | \$0.50 | \$ 0.50 | \$ 0.50 | \$ 0.50 |
| ** Holiday | \$4.56 | \$4.56 | \$ 4.56 | \$ 4.56 |
| TOTAL FRINGES: | | \$ 35.14 | \$ 35.14 | \$ 35.14 |
| 3 PAYROLL TAXES & INSURANCE | | | | |
| | RATE | | | |
| FICA (Social Security & Medicare) | 7.65% | \$ 4.30 | \$ 6.46 | \$ 8.61 |
| Federal Unemployment | 0.60% | \$ 0.34 | \$ 0.51 | \$ 0.68 |
| Metro Tax | 0.34% | \$ 0.19 | \$ 0.29 | \$ 0.38 |
| New York Unemployment | 8.33% | \$ 4.68 | \$ 7.03 | \$ 9.37 |
| Workers Comp | 7.80% | \$ 4.39 | \$ 4.39 | \$ 4.39 |
| General Liability | 15.50% | \$ 8.72 | \$ 13.08 | \$ 17.44 |
| TOTAL PAYROLL TAXES & INSURANCE: | | \$ 22.63 | \$ 31.75 | \$ 40.87 |
| 4 TOTAL LABOR RATE, TAXES & INSURANCE | | \$ 114.04 | \$ 151.30 | \$ 188.55 |

** Holiday computed as 80 hour cost divided by 1,920 (est. 48 week work year)

VERDE ELECTRIC CORP LABOR RATE BREAKDOWN

EFFECTIVE DATES:

FROM: 3/4/2025
 TO: 3/3/2026

TRADE CLASSIFICATION:

OPERATOR JOURNEYMAN

UNION:

OPERATING ENGINEERS

LOCAL NO:

137

| | | Straight Time | Overtime & Saturday | Sunday |
|---|-------------|---------------|------------------------|-----------|
| 1 HOURLY RATE | | | | |
| | | \$ 62.07 | \$ 93.11 | \$ 124.14 |
| 2 FRINGES: | | | | |
| | RATE | | | |
| Welfare | \$21.40 | \$ 21.40 | \$ 21.40 | \$ 21.40 |
| Vacation | \$3.20 | \$ 3.20 | \$ 3.20 | \$ 3.20 |
| Savings/PSL | \$1.10 | \$ 1.10 | \$ 1.10 | \$ 1.10 |
| Pension | \$5.18 | \$ 5.18 | \$ 5.18 | \$ 5.18 |
| Apprenticeship | \$1.30 | \$ 1.30 | \$ 1.30 | \$ 1.30 |
| National Training | \$0.10 | \$ 0.10 | \$ 0.10 | \$ 0.10 |
| Annuity | \$8.50 | \$ 8.50 | \$ 8.50 | \$ 8.50 |
| IAF | \$0.50 | \$ 0.50 | \$ 0.50 | \$ 0.50 |
| Supplemental Dues | 3.75% | \$ 2.33 | \$ 3.49 | \$ 4.66 |
| PAC | \$0.05 | \$ 0.05 | \$ 0.05 | \$ 0.05 |
| LMCT | \$1.00 | \$ 1.00 | \$ 1.00 | \$ 1.00 |
| ** Holiday | \$5.49 | \$ 5.49 | \$ 5.49 | \$ 5.49 |
| TOTAL FRINGES: | | \$ 50.14 | \$ 51.31 | \$ 52.47 |
| 3 PAYROLL TAXES & INSURANCE | | | | |
| | RATE | | | |
| FICA (Social Security & Medicare) | 7.65% | \$ 4.75 | \$ 7.12 | \$ 9.50 |
| Federal Unemployment | 0.60% | \$ 0.37 | \$ 0.56 | \$ 0.74 |
| Metro Tax | 0.34% | \$ 0.21 | \$ 0.32 | \$ 0.42 |
| New York Unemployment | 8.33% | \$ 5.17 | \$ 7.76 | \$ 10.34 |
| Workers Comp | 7.80% | \$ 4.84 | \$ 4.84 | \$ 4.84 |
| General Liability | 15.50% | \$ 9.62 | \$ 14.43 | \$ 19.24 |
| TOTAL PAYROLL TAXES & INSURANCE: | | \$ 24.96 | \$ 35.03 | \$ 45.09 |
| 4 TOTAL LABOR RATE, FRINGES, TAXES & INSURANCE | | | | |
| | | \$ 137.18 | \$ 179.44 | \$ 221.70 |

** Holiday computed as 80 hour cost divided by 1,920 (est. 48 week work year)



OFFER

Cranesville Block Co., Inc.
1250 Riverfront Center
Amsterdam, NY 12010
www.cranesville.com

Phone: 518-684-6000
Dispatch: 518-684-6085
Sales: 518-684-6078
Sales Fax: 518-684-0128
Credit: 518-684-6004

Ready Mixed Concrete – Aggregates – Masonry Units – Precast – Masonry Supplies

Customer Name Verde Electric
Attention Anthony Mauriello
Office Phone (914) 664-7000
Cell Phone (914) 652-3908
Email amauriello@verdeelectric.com
Fax (914) 668-7997
Yards 800
Quote Number 00011972

Project Name Broadway Improvements Newburgh
Project Address Robinson Ave
Project Newburgh, NY
Address(Cont'd)
Quote Date 8/8/2025
Expiration Date 12/31/2025
Project Salesman Bill Cobey
Salesman Mobile 845-313-0626
Salesman Email wcobey@cranesville.com
Sales Assoc. Patti Bieniek
Sales Assoc. Phone 518-684-6119
Sales Assoc. Email pbieniek@cranesville.com

| Quantity | Product | Line Item Description | Sales Price | UM |
|----------|------------------|--|-------------|----|
| 800.00 | Class D Concrete | Straight Cement for colored concrete (Included 1.5 lbs. fiber for sidewalks) | \$196.45 | CY |

***Due to the potential disruption in the cement supply chain, we reserve the right to requote as necessary.**

Above mixes are designed to have a 2"- 4" slump.
If a 4"- 6" slump is required a Midrange will need to be used at additional price listed below
If a 7"-9" slump is required a Super Plasticizer will need to be used at additional price listed below
Plants are NYSDOT approved; not NRMCA.

Additional Information: **SIKA COLOR #14 GRAY (4 BAGS/YARD) \$109.50/CY**

**Please see the Terms & Conditions on the last page of this Offer.
MINIMUM OF A 6% INCREASE ON ALL BELOW PRODUCTS FOR EACH SUBSEQUENT YEAR.**

Class D base price w/ fiber \$196.45/CY

Sample load CID 11 CY @ \$196.45
Sika color 11 CY @ \$109.50
Environmental Charge 1 ea @ \$13.99
Color washout 1 ea @ \$50.00
fuel surcharge 1 ea @ \$25.00

Total: \$3,454.44

deduct fiber -12.45 = ~~\$314.04 / CY~~
= \$301.59



OFFER

Cranesville Block Co., Inc.
 1250 Riverfront Center
 Amsterdam, NY 12010
 www.cranesville.com

Phone: 518-684-6000
 Dispatch: 518-684-6085
 Sales: 518-684-6078
 Sales Fax: 518-684-0128
 Credit: 518-684-6004

Ready Mixed Concrete – Aggregates – Masonry Units – Precast – Masonry Supplies

| Additional Products and Services – Mont / Fish / Lib | | | | | |
|---|---------------|--|-------------|-------------------------------|-------------|
| Environmental Surcharge (mandatory) | \$13.99 /load | Small Stone | \$2.75 /cy | Non-Chloride 1% | \$7.15 /cy |
| Fuel Surcharge (mandatory) (subject to change) | \$25.00/load | Fiber (1 lb per cy) | \$9.25 /cy | Non-Chloride 2% | \$11.65 /cy |
| Color Washout | \$50.00 /load | Fiber (1.5 lb per cy) | \$12.45 /cy | Calcium 1% | \$5.55 /cy |
| Saturday Delivery | \$75.00 /load | Mid-Range Water Reducer | \$5.00 /cy | Calcium 2% | \$10.30 /cy |
| Truck Time (Overtime) Charge (per minute) | \$2.00 /min | High Range Water Reducer (Super Plasticizer) | \$9.25 /cy | Retarder | \$5.55 /cy |
| Cold Weather (Exact weather subject to ACI standards) | \$12.50/cy | Corrosion Inhibitor | Inquire | Moisture Vapor Reducing Admix | Inquire |
| Ice (hot weather Concrete) | Inquire | | | | |

| Terms and Conditions | |
|--|---|
| Any purchase order sent by Buyer and not signed by an authorized representative of Seller will be invalid, regardless of commencement of delivery. | |
| <ul style="list-style-type: none"> * This offer is expressly limited to and expressly made conditional on buyer's acceptance of these terms and conditions and (a copy of the Consolidated Joint Application for Extension of Credit available at http://www.cranesville.com/pdf_files/cra2011app.pdf). Seller objects to any alternate terms and conditions contained in any purchase order or any other document sent by buyer. Seller will not accept terms of any purchase order, which incorporate by reference terms and conditions of a separate and distinct agreement. * All invoices are due net thirty (30) days from delivery or sale; invoices remaining delinquent beyond thirty (30) days shall bear an 18% per annum finance charge. * Seller's delivery of goods to buyer constitutes buyer's acceptance of this offer in the absence of buyer's written signature. * Seller's warranty limited to full refund of purchase price. * This offer is not contingent upon strikes, riots, authority of law, acts of God and/or other causes beyond our control. Access to the project and individual delivery locations must be such that normal drive ready mixed, boom, tanker, fit-axle or tractor trailer trucks can maneuver under their own power at all times. The Seller reserves the right to stop deliveries if roadways or approaches are unsatisfactory to him/her. The buyer assumes all liability for damage to sidewalks, driveways or other property beyond the curb line and agrees to indemnify the Seller against all liability loss and expenses incurred as a result of such delivering including damage to Seller's equipment and loss of time. * The products have been designed to attain the indicated compressive strengths in accordance with recognized testing methods and standards. Field results may differ substantially due to variables such as waiting time, placing methods, weather, handling after placement, addition of outside materials by buyer or request of buyer, such as water, and other variables beyond the control of the Seller. The Seller hereby disclaims any liability and/or warranty, expressed or implied should the buyer not use proper testing, placing and curing methods (ACI-ASTM). Upon delivery, it is the buyer's responsibility to confirm the correct product or mix has been delivered. There will be no credit or adjustment to billing for incorrect material incorporated into the work. | <ul style="list-style-type: none"> * Sales tax will be applied to Seller Invoice(s) unless appropriate documentation is received before ordering product. * Prices are based on full truckloads (7+CY). A short load will be charged on orders less than 7 yds. (Contact sales for a copy of the rates.) A balance on a plus order is one load of ten yards or less. * Heating or cooling of concrete is not included in product price. * If color is used on any job, an environmentally approved location must be available for a truck to rinse. * Hours of operation Monday - Friday 7:00 AM- 6:30 PM. Saturday 8 AM - 12 PM. Contact sales for deliveries outside of these hours. * All products that are ordered and are not listed on this quote will be billed at the standard price. * Delivery times and truck spacing are targets Seller strives for but does not guarantee due to the demands of the industry. * Truck time will be charged after the allotted 4 minutes per yard, per truck, at the rate set forth in the "Additional Products and Services" schedule. Truck time is calculated, by truck, "At Job" until "Stop Four." * All offered prices are subject to price increase(s) due to cement and/or fuel cost increases. * The above pricing is based on the project's total yardage and specified mixes. Seller and other material producing companies reserve the right to re-price based on changes in quantity and/or mix, or extraneous factors. All quoted products are standard mix designs unless specifications have been provided prior to quotation. * Waiver of Consequential Damages: Purchaser, for good and valuable consideration, and as a condition of purchase, waives against Seller any and all damages arising directly, or as a consequence of, Seller providing defective or non-conforming goods. Such waiver shall include damages arising as a direct or indirect result of costs or property damage, to adjoining work caused or created by non-conforming or defective product provided by Seller. * The "Expiration Date" includes all terms and pricing listed. Standard pricing will apply thereafter. |

Price not enforceable by Buyer if not signed within 15 days of receipt. Please sign offer and return before ordering.

ACCEPTED BY:

DATE:

This is the last page of this Offer.



ACCOUNT MANAGER: HEATHER SCHEER
 HEATHER.SCHEER@WHITECAP.COM
 860-573-8566

CUSTOMER: VERDE ELECTRIC
 NAME: ANTHONY MAURIELLO
 JOB: BROADWAY NEWBURGH PTS

2025-08-06 Whitecap 18x36" Bluestone

| Description | Packaging | Item | Each Unit (ea) | QTY | Total |
|--------------------------------------|----------------|--------|----------------|-----|--------------|
| 18"X36" Bluestone- Rigid Black | 18" x 36" | 599712 | \$ 270.97 | 6 | \$ 1,625.82 |
| 18"X36" Bluestone- Rigid Blue | 18" x 36" | 599714 | \$ 270.97 | 6 | \$ 1,625.82 |
| 18"X36" Bluestone- Rigid Green | 18" x 36" | 599716 | \$ 270.97 | 6 | \$ 1,625.82 |
| 18"X36" Bluestone- Flex Black | 18" x 36" | 599711 | \$ 270.97 | 2 | \$ 541.94 |
| 18"X36" Bluestone Flex Blue | 18" x 36" | 599713 | \$ 270.97 | 2 | \$ 541.94 |
| Bluestone Texture Touch-up Skin | 18" x 18" | 599625 | \$ 104.89 | 2 | \$ 209.78 |
| Bluestone 9" Texture Roller Sleeve | 9" x 3.25" | 600017 | \$ 88.80 | 2 | \$ 177.60 |
| 2" Chisel | 2" x 7.5" | 618415 | \$ 18.34 | 2 | \$ 36.69 |
| 4" Chisel | 4" x 8" | 618416 | \$ 29.94 | 2 | \$ 59.89 |
| 8" Chisel | 8" x 8" | 618417 | \$ 32.99 | 2 | \$ 65.98 |
| 3/16" Touch-Up Wheel | 13.5" x 2.5" | 600666 | \$ 64.21 | 2 | \$ 128.42 |
| Perma-Cast® Clear Liquid Release | 5 Gal. | 619060 | \$ 138.14 | 72 | \$ 9,946.08 |
| SikaCem®-100 PRO 350® | 5 Gal. | 761327 | \$ 289.17 | 37 | \$ 10,699.29 |
| Clear Guard® Slip-Resistant Additive | Box of 6-1 lb. | 618584 | \$ 21.57 | 37 | \$ 798.05 |

Two Sets

Notes:

Stamp Pattern # S4210
 Recommended Contractor Stamp Set: 9 Rigid, 2 Flex, 1 Skin, 1 Roller Sleeve
 Suggested Touch-Up / Detail Tools- Chisels: 2", 4", 8", & 12" Touch-up Wheel: 3/16"

Liquid Release Assumes 750 sf./ pail
 Lithochrome Wax assumes 200 Sf/Gal
 Pro 350 assumes 300-400 sq. ft./gal.

Approximate freight \$300.00/pallet
 Does not include Taxes
 Based on approximate 51,000 SF



Mount Ple... 10PM 10532 What can we help you find today?



Wooster

9 in. x 1/2 in. Pro Surpass Shed-Resistant Knit High-Density Fabric Roller Cover Applicator/Tool (3-Pack)

★★★★★ (1887) Questions & Answers (20)



RESEALABLE BAG



BULK PRICE ELIGIBLE
\$12.48

Buy 4 or more \$10.61

Buy 4 or More, Get 15% Off

0 of 4 items

15% Off

Add 4 more to quality
[Shop This Offer](#)

- Fast results
- Shed-resistant knit
- Even coverage
- [View More Details](#)

Mount Pleasant Store

✓ 46 in stock Aisle 36, Bay 006

Package Quantity: 3

1

Nap Size/Thickness (in.): 1/2

Product Width (in.): 9 in

+6



Mount Ple... 10PM 10532 What can we help you find today?



Shop All

Internet # 100187725 Model # 00R0550000 Store SKU # 1000022322

Paint Supplies / Paint Roller Extension Poles / Wooster Paint Roller Extension Poles

Top Rated

Wooster

Sherlock 4 ft. - 8 ft. Adjustable Extension Pole

★★★★★ (2040) Questions & Answers (47)

\$27.48

Pay \$2.48 after \$25 OFF your total qualifying purchase upon opening a new card.



Apply for a Home Depot Consumer Card



Buy 4 or More, Get 15% Off

0 of 4 items

15% Off

Add 4 more to qualify

[Shop This Offer](#)

- Thumb lever locks in 6 in. increments to adjust pole length
- Threaded tip fits most roller frames and tools
- Sturdy and durable
- [View More Details](#)

Mount Pleasant Store

✓ 35 in stock Aisle 36, Bay SC1

Minimum length (ft.): 4

Maximum length (ft.): 8





Mount Ple... 10PM



10532

What can we help you find today?



Shop

Best Seller

9 in. Heavy Duty 5-Wire Paint Roller Frame

★★★★★ (1145) Questions & Answers (7)

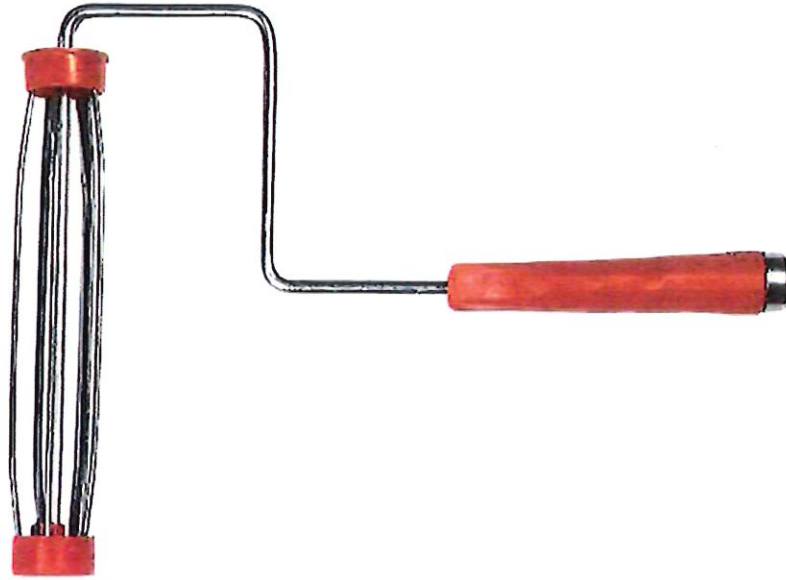
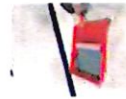

Hover Image to Zoom

\$4.48



- For use with all standard 9" paint roller covers
- 5-wire cage durably crafted with sturdy steel
- Threaded handle end is compatible with most extension poles
- [View More Details](#)

Mount Pleasant Store

✓ 300 in stock Aisle 36, Bay 008

Pickup at

[Mount Pleasant](#)

Delivering to [10532](#)

Pickup Today
300 in stock
FREE

Delivery Tomorrow
304 available
FREE

[Check Nearby Stores](#)

[Delivery Details](#)

Order within **5 hrs 57 mins** to get it by **Tomorrow**



Get it delivered Today for \$2.99. Schedule your delivery in checkout.

One-Time Purchase

9 in. Metal Paint Roller Tray

★★★★★ (991) Questions & Answers (3)

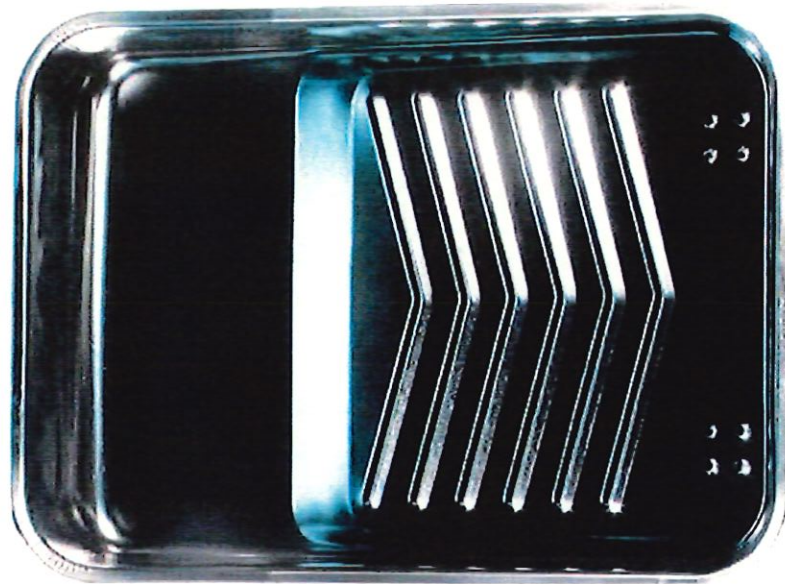

Hover Image to Zoom

\$3.98



- Designed for use with standard 9 in. roller covers and frames
- Made with solvent-resistant metal for durability
- Holds up to 1 quart paint or stain
- [View More Details](#)

Mount Pleasant Store

✓ 111 in stock Aisle 36, Bay 008

Pickup at

[Mount Pleasant](#)

Delivering to 10532

Pickup
Today
111 in stock
FREE

Delivery
Tomorrow
428 available
FREE

[Check Nearby Stores](#)

[Delivery Details](#)

Get it delivered Today for \$2.99. Schedule your delivery in checkout.

1 +

[Add to Cart](#)

PayPal

Pay in 4 interest-free payments on purchases of \$30-\$1,500 with **PayPal**. [Learn more](#)

[Share](#) [Print](#)

WHITE CAP ON ACCOUNT



511 - Newington CT (AHH) (PZ10)
 91 Holmes Rd
 Newington, CT, 06111
 (860) 665-9400

QUOTE

68680989

**THIS IS A QUOTE ONLY DO NOT SHIP OR
 TENDER FUNDS**

Sold To: 10000215303
 VERDE ELECTRIC
 89 EDISON AVENUE
 MT VERNON, NY, 10550

Ship To : Broadway Traffic Signal Improvements,10005427450
 BROADWAY
 NEWBURGH, NY, 12550
Job Site Contact: anthony mauriello
Job Site Phone:
Map #:

10:44 AM

Ordered By: GEORGE CARUSO

Contact Phone:

| Quote Number | | Quote Date | Valid Until | Request Date | Sales Person | |
|--------------|--------------|--|--------------|-----------------|--------------|-------------|
| 68680989 | | 09/29/2025 | 10/06/2025 | 09/29/2025 | Scheer, H | |
| Terms | | Shipping Method | Quote Name | Customer PO | Created By | |
| N30D | | 10. WCD Common Carrier | ADA TILES | ADA TILES | Scheer, H | |
| SEQ | Part# H/M | Description | Ord Quantity | U/M Unit WT | Price COO | Amount |
| 10 | 546CI230WSPA | 24"X30" PATINA CAST IRON WET SET TUFTILE | 116 | EA 47.77 LBS | \$133.23 | \$15,454.68 |
| 20 | SHIPPING | SHIPPING AND HANDLING | 1 | EA 0 LBS | \$570.00 | \$570.00 |

| | |
|------------------------|-------------|
| Shipped amount | \$16,024.68 |
| Order charges | \$0.00 |
| Tax amount | \$0.00 |
| Lumber Tax rate/amount | 1.00% |
| Quote total | \$16,024.68 |

Shipped Weight: 5,541.32 Customer acceptance signature: _____ Date : _____

ALL ITEMS AND QUANTITIES REQUIRE CUSTOMER REVIEW AND APPROVAL
AVAILABILITY AND LEAD TIMES ARE SUBJECT TO CHANGE
SPECIAL ORDERED ITEMS ARE SUBJECT TO MANUFACTURER APPROVAL PRIOR TO RETURN.
QUOTE IS SUBJECT TO EXPIRATION AS INDICATED IN THE ABOVE 10/06/2025 DATE.

The White Cap Family of Brands includes All-Tex Waterproofing Solutions, Harmac, Kenseal, Marvel Building & Masonry Supply, MASONPRO, and Williams Equipment & Supply. Learn more at About.WhiteCap.com.

Note: Due to volatility in the steel market from the recent Section 232 decision, domestic supply constraints and active trade negotiations, pricing is subject to change on a daily basis. Please review your pricing and contact your sales associate immediately to secure products and pricing.

WHITE CAP RESERVES THE RIGHT TO ADJUST PRICES TO REFLECT THE IMPACT OF ANY TARIFFS, DUTIES, OR SIMILAR GOVERNMENTAL CHARGES IMPOSED OR INCREASED AFTER THE DATE OF THIS QUOTE BUT PRIOR TO EXPIRATION.



OFFER

Cranesville Block Co., Inc.
 1250 Riverfront Center
 Amsterdam, NY 12010
 www.cranesville.com

Phone: 518-684-6000
 Dispatch: 518-684-6085
 Sales: 518-684-6078
 Sales Fax: 518-684-0128
 Credit: 518-684-6004

Ready Mixed Concrete – Aggregates – Masonry Units – Precast – Masonry Supplies

Customer Name Verde Electric
 Attention Tony .
 Office Phone (914) 664-7000
 Cell Phone 845-337-9903
 Email albtony@gmail.com
 Fax (914) 668-7997
 Yards 940
 Quote Number 00010099

Project Name Newburgh Broadway Recycling
 Project Address tbd
 Project Newburgh, NY
 Address(Cont'd)
 Quote Date 2/24/2025
 Expiration Date 12/31/2025
 Project Salesman Bill Cobey
 Salesman Mobile 845-313-0626
 Salesman Email wcobey@cranesville.com
 Sales Assoc. Patti Bieniek
 Sales Assoc. Phone 518-684-6119
 Sales Assoc. Email pbieniek@cranesville.com

| Quantity | Product | Line Item Description | Sales Price | UM |
|----------|------------------|--|-------------|----|
| 140.00 | Class A Concrete | | \$171.00 | CY |
| 690.00 | Class D Concrete | Excludes fiber or water reducer | \$184.00 | CY |
| 1.00 | Class D Concrete | Includes 1.5 lbs fiber and water reducer (sidewalks) | \$199.45 | CY |

***Due to the potential disruption in the cement supply chain, we reserve the right to requote as necessary.**

Above mixes are designed to have a 2"- 4" slump.

If a 4"- 6" slump is required a Midrange will need to be used at additional price listed below
 If a 7"-9" slump is required a Super Plasticizer will need to be used at additional price listed below
 Plants are NYSDOT approved; not NRMCA.

Please see the Terms & Conditions on the last page of this Offer.

MINIMUM OF A 6% INCREASE ON ALL BELOW PRODUCTS FOR EACH SUBSEQUENT YEAR.



Peckham Industries, Inc.
 172 Prospect Hill Rd, Brewster, NY 10509
 (914) 949-2000

Job Description: BROADWAY TRAFFIC SIG IMP - NEWBURGH

*** PRICING IS ONLY VALID FOR 30 DAYS FROM QUOTE DATE ***

| | | | |
|-----------------------------|-------------------|------------------------|---------------------------------|
| Quote Date: | 02/10/2025 | Customer: | Verde Electric Maintenance Inc. |
| Job Completion Date: | | | 89 Edison Avenue |
| Quote Expiration: | 03/02/2025 | | Mount Vernon, NY, 10550 |
| Project Location: | | Project Contact Name: | TONY MAVRA |
| Asphalt Index Type: | | Project Phone No: | 845-337-9903 |
| Asphalt Base Price: | | Project Fax No: | |
| <u>Salesman Information</u> | | Project Contact Email: | ALBTONY@GMAIL.COM |
| Name: | Joe Tetz | Job No: | |
| Phone: | | P.O. No: | |
| Mobile: | | Property Owner | |
| Email: | jtez3@peckham.com | Name: | |
| Quote ID: | Q-11772 | Street: | |
| | | City, State Zip: | |

| QTY | UOM | Product Description / DOT Item Code | Unit Price | | Extended Total | |
|------|------|--|----------------------------|-----------|--------------------|-----------|
| | | | FOB | Delivered | FOB | Delivered |
| 1 | Tons | 4900 - Tipping Fee Concrete Middletown HMA | \$12.00 | - | \$12.00 | - |
| 1 | Tons | 4898 - TIPPING FEE MILLINGS Middletown HMA | \$12.00 | - | \$12.00 | - |
| 85 | Tons | 1204 - SUPERPAVE 19 MM (WMA) - 64S-22 Middletown HMA | \$91.00 | - | \$7,735.00 | - |
| 88 | Tons | 1208 - SUPERPAVE 9.5 MM (WMA) 64S-22 Middletown HMA | \$94.00 | - | \$8,272.00 | - |
| 1650 | Tons | 1300 - 304. - ITEM 4 Chester Quarry | \$16.50 | - | \$27,225.00 | - |
| 260 | Tons | 1306 - 203.07 SELECT GRANULAR FILL (M Chester Quarry | \$16.50 | - | \$4,290.00 | - |
| | | | Total | | \$47,546.00 | - |
| | | | Total including tax | | \$51,409.11 | - |

special note

SUPERPAVE QUOTED WITH 64S-22 AND WMA IF 64E OIL IS NEEDED PLEASE ADD 9.00 PER TON.
 ONLY CLEAN MILLINGS WILL BE ACCEPTED

ALL PRICING EXPIRES 12/31/25

Salesperson Signature: _____
 Name: _____ Date: _____

Customer Signature: _____
 Name: _____ Date: _____

WHITE CAP ON ACCOUNT



511 - Newington CT (AHH) (PZ10)
 91 Holmes Rd
 Newington, CT, 06111
 (860) 665-9400

QUOTE

67755862

THIS IS A QUOTE ONLY DO NOT SHIP OR
 TENDER FUNDS

Sold To: 10000215303
 VERDE ELECTRIC
 89 EDISON AVENUE
 MT VERNON, NY, 10550

Ship To : Broadway Traffic Signal Improvements,10005427450
 BROADWAY
 NEWBURGH, NY, 12550
 Job Site Contact: ANTHONY ANTHONY
 Job Site Phone: 914-652-3908
 Map #:

12:45 PM

Ordered By: ANTHONY ANTHONY

Contact Phone: 914-6523908

| Quote Number | Quote Date | Valid Until | Request Date | Sales Person | | |
|--------------|-----------------|--|--------------|-----------------|--------------|-------------|
| 67755862 | 08/12/2025 | 08/19/2025 | 08/12/2025 | Scheer, H | | |
| Terms | Shipping Method | Quote Name | Customer PO | Created By | | |
| N30D | 2. Our Truck | BROADWAY | broadway | Scheer, H | | |
| SEQ | Part# H/M | Description | Ord Quantity | U/M Unit WT | Price COO | Amount |
| 10 | 434666G510 | 6"X6" W2.9 6GA 5'X10' WIRE MESH MAT | 1100 | EA 20.69 LBS | \$17.43 | \$19,173.00 |
| 20 | 199EB124010 | 1/2"X4"X10' FIBER EXPANSION BOARD 100FT/BUNDLE | 7500 | FT .32 LBS | \$0.38 | \$2,850.00 |
| 30 | 505VC12 | 1/2"X10' TOP VOID CAP SOLD/FOOT | 7400 | FT .08 LBS | \$0.37 | \$2,738.00 |
| 40 | 3392SPF2416 | 2"X4"X16' #2 SPF LUMBER | 200 | EA 18.66 LBS | \$12.79 | \$2,558.00 |
| 50 | 339CDX3448 | 3/4"X4'X8' CDX PLYWOOD 23/32" 18MM | 80 | EA 60 LBS | \$34.56 | \$2,764.80 |

| | |
|------------------------|-------------|
| Shipped amount | \$30,083.80 |
| Order charges | \$0.00 |
| Tax amount | \$0.00 |
| Lumber Tax rate/amount | 1.00% |
| Quote total | \$30,083.80 |

Adjustments for #163 - 2022 Chevy Silverado 2500 Pick up Truck in All Saved Models

March 4, 2026

Chevrolet SILVERADO 2500HD 4X4 DIESEL
 Light Duty Trucks

 Size Class:
3
 Weight:
 N/A

Configuration for SILVERADO 2500HD 4X4 DIESEL

 Power Mode **Diesel** Wheelbase **149.4 Inches**
 Gross Vehicle Weight Rating **11200 Pounds**
Blue Book Rates

** FHWA Rate is equal to the monthly ownership cost divided by 176 plus the hourly estimated operating cost.

| | Ownership Costs | | | | Estimated Operating Costs Hourly USD \$19.35 | FHWA Rate** Hourly USD \$41.11 |
|---------------------------------------|-----------------------|-----------------------|---------------------|--------------------|--|--------------------------------------|
| | Monthly | Weekly | Daily | Hourly | | |
| Published Rates | USD \$3,830.00 | USD \$1,075.00 | USD \$270.00 | USD \$41.00 | USD \$19.35 | USD \$41.11 |
| Adjustments | | | | | | |
| Region (100%) | - | - | - | - | | |
| Model Year (2022: 97.06%) | (USD \$112.73) | (USD \$31.64) | (USD \$7.95) | (USD \$1.21) | | |
| Adjusted Hourly Ownership Cost (100%) | - | - | - | - | | |
| Hourly Operating Cost (100%) | | | | | - | |
| Total: | USD \$3,717.27 | USD \$1,043.36 | USD \$262.05 | USD \$39.79 | USD \$19.35 | USD \$40.47 |

Non-Active Use Rates

| | Hourly |
|--------------|-------------|
| Standby Rate | USD \$12.74 |
| Idling Rate | USD \$28.85 |

Rate Element Allocation

| Element | Percentage | Value |
|-----------------------------|------------|-------------------|
| Depreciation (ownership) | 27.57% | USD \$1,055.91/mo |
| Overhaul (ownership) | 39.7% | USD \$1,520.38/mo |
| CFC (ownership) | 16.48% | USD \$631.24/mo |
| Indirect (ownership) | 16.25% | USD \$622.46/mo |
| Fuel (operating) @ USD 3.83 | 39.95% | USD \$7.73/hr |

Revised Date: 1st quarter 2026

These are the most accurate rates for the selected Revision Date(s). However, due to more frequent online updates, these rates may not match Rental Rate Blue Book® Print. Visit the Cost Recovery Product Guide on our Help page for more information.

The equipment represented in this report has been exclusively prepared for (rdleonardo@verdeelectric.com)

Adjustments for Rack/Box Truck 156 in All Saved Models

 Miscellaneous 6X6 70KGVW DSL
 On-Highway Truck Tractors

 Size Class:
60,001 lbs & Over
 Weight:
 N/A

Configuration for 6X6 70KGVW DSL

| | | | |
|------------------------------|--------------------|------------|-----------------|
| Axle Configuration | 6X6 | Horsepower | 450.0 hp |
| Maximum Gross Vehicle Weight | 70000.0 lbs | Power Mode | Diesel |

Blue Book Rates

** FHWA Rate is equal to the monthly ownership cost divided by 176 plus the hourly estimated operating cost.

| | Ownership Costs | | | | Estimated Operating Costs | FHWA Rate** |
|---------------------------------------|-----------------------|-----------------------|---------------------|--------------------|---------------------------|--------------------|
| | Monthly | Weekly | Daily | Hourly | Hourly | Hourly |
| Published Rates | USD \$4,465.00 | USD \$1,250.00 | USD \$315.00 | USD \$47.00 | USD \$61.38 | USD \$86.75 |
| Adjustments | | | | | | |
| Region (New York: 104%) | USD \$178.60 | USD \$50.00 | USD \$12.60 | USD \$1.88 | | |
| Model Year (2023: 99.94%) | (USD \$2.63) | (USD \$0.74) | (USD \$0.19) | (USD \$0.03) | | |
| Adjusted Hourly Ownership Cost (100%) | - | - | - | - | | |
| Hourly Operating Cost (100%) | | | | | - | |
| Total: | USD \$4,640.97 | USD \$1,299.26 | USD \$327.41 | USD \$48.85 | USD \$61.38 | USD \$87.75 |

Non-Active Use Rates

| | Hourly |
|--------------|-------------|
| Standby Rate | USD \$16.50 |
| Idling Rate | USD \$68.61 |

Rate Element Allocation

| Element | Percentage | Value |
|-----------------------------|------------|-------------------|
| Depreciation (ownership) | 42.27% | USD \$1,887.24/mo |
| Overhaul (ownership) | 37.42% | USD \$1,670.85/mo |
| CFC (ownership) | 9.36% | USD \$418.00/mo |
| Indirect (ownership) | 10.95% | USD \$488.91/mo |
| Fuel (operating) @ USD 3.83 | 68.82% | USD \$42.24/hr |

Revised Date: 1st quarter 2026

These are the most accurate rates for the selected Revision Date(s). However, due to more frequent online updates, these rates may not match Rental Rate Blue Book® Print. Visit the Cost Recovery Product Guide on our Help page for more information.

The equipment represented in this report has been exclusively prepared for (rdileonardo@verdeelectric.com)

Adjustments for Rack/Box Truck 156 in All Saved Models

March 4, 2026

Miscellaneous 6X6 70KGVW DSL
 On-Highway Truck Tractors

 Size Class:
60,001 lbs & Over
 Weight:
 N/A

Configuration for 6X6 70KGVW DSL

| | | | |
|------------------------------|--------------------|------------|-----------------|
| Axle Configuration | 6X6 | Horsepower | 450.0 hp |
| Maximum Gross Vehicle Weight | 70000.0 lbs | Power Mode | Diesel |

Blue Book Rates

** FHWA Rate is equal to the monthly ownership cost divided by 176 plus the hourly estimated operating cost.

| | Ownership Costs | | | | Estimated Operating Costs Hourly | FHWA Rate** Hourly |
|---------------------------------------|-----------------------|-----------------------|---------------------|--------------------|-------------------------------------|-----------------------|
| | Monthly | Weekly | Daily | Hourly | | |
| Published Rates | USD \$4,465.00 | USD \$1,250.00 | USD \$315.00 | USD \$47.00 | USD \$61.38 | USD \$86.75 |
| Adjustments | | | | | | |
| Region (New York: 104%) | USD \$178.60 | USD \$50.00 | USD \$12.60 | USD \$1.88 | | |
| Model Year (2023: 99.94%) | (USD \$2.63) | (USD \$0.74) | (USD \$0.19) | (USD \$0.03) | | |
| Adjusted Hourly Ownership Cost (100%) | - | - | - | - | | |
| Hourly Operating Cost (100%) | | | | | - | |
| Total: | USD \$4,640.97 | USD \$1,299.26 | USD \$327.41 | USD \$48.85 | USD \$61.38 | USD \$87.75 |

Non-Active Use Rates

| | Hourly |
|--------------|-------------|
| Standby Rate | USD \$16.50 |
| Idling Rate | USD \$68.61 |

Rate Element Allocation

| Element | Percentage | Value |
|-----------------------------|------------|-------------------|
| Depreciation (ownership) | 42.27% | USD \$1,887.24/mo |
| Overhaul (ownership) | 37.42% | USD \$1,670.85/mo |
| CFC (ownership) | 9.36% | USD \$418.00/mo |
| Indirect (ownership) | 10.95% | USD \$488.91/mo |
| Fuel (operating) @ USD 3.83 | 68.82% | USD \$42.24/hr |

Revised Date: 1st quarter 2026

These are the most accurate rates for the selected Revision Date(s). However, due to more frequent online updates, these rates may not match Rental Rate Blue Book®. Print. Visit the Cost Recovery Product Guide on our Help page for more information.

The equipment represented in this report has been exclusively prepared for (rdileonardo@verdeelectric.com)

Adjustments for pc-78us-10 in All Saved Models

Komatsu PC78US-10
Crawler Mounted Hydraulic Excavators



Size Class:
6.5 - 8.4 mt
Weight:
N/A

Configuration for PC78US-10

Horsepower **65.5 hp** Operating Weight **17747.0 lbs**
Power Mode **Diesel**

Blue Book Rates

** FHWA Rate is equal to the monthly ownership cost divided by 176 plus the hourly estimated operating cost.

| | Ownership Costs | | | | Estimated Operating Costs Hourly USD \$17.63 | FHWA Rate** Hourly USD \$55.16 |
|---------------------------------------|-----------------------|-----------------------|---------------------|--------------------|--|--------------------------------------|
| | Monthly | Weekly | Daily | Hourly | | |
| Published Rates | USD \$6,605.00 | USD \$1,850.00 | USD \$465.00 | USD \$70.00 | | |
| Adjustments | | | | | | |
| Region (100%) | - | - | - | - | | |
| Model Year (2022: 99.94%) | (USD \$4.19) | (USD \$1.17) | (USD \$0.30) | (USD \$0.04) | | |
| Adjusted Hourly Ownership Cost (100%) | - | - | - | - | | |
| Hourly Operating Cost (100%) | | | | | - | |
| Total: | USD \$6,600.81 | USD \$1,848.83 | USD \$464.70 | USD \$69.96 | USD \$17.63 | USD \$55.13 |

Non-Active Use Rates

| | Hourly |
|--------------|-------------|
| Standby Rate | USD \$20.95 |
| Idling Rate | USD \$42.27 |

Rate Element Allocation

| Element | Percentage | Value |
|-----------------------------|------------|-------------------|
| Depreciation (ownership) | 31.78% | USD \$2,098.95/mo |
| Overhaul (ownership) | 44.15% | USD \$2,916.09/mo |
| CFC (ownership) | 15.44% | USD \$1,019.92/mo |
| Indirect (ownership) | 8.63% | USD \$570.03/mo |
| Fuel (operating) @ USD 3.83 | 27.06% | USD \$4.77/hr |

Revised Date: 1st quarter 2026

These are the most accurate rates for the selected Revision Date(s). However, due to more frequent online updates, these rates may not match Rental Rate Blue Book® Print. Visit the Cost Recovery Product Guide on our Help page for more information.

The equipment represented in this report has been exclusively prepared for (rdileonardo@verdeelectric.com)



Insurance | Risk Management | Consulting

30 Century Hill Drive, Suite 200
Latham, NY 12110
USA

518-869-3535
www.ajg.com

January 26, 2026

Verde Electric Maintenance Corporation.
89 Edison Avenue
Mount Vernon, NY 10550

**Re: Workers Compensation Experience Modifications
Verde Electric Maintenance Corporation.**

Dear Tricia:

Please allow this letter to acknowledge and confirm the Workers Compensation Experience Modification for the above.

The EMR's are as follows:

| <u>Effective Year</u> | <u>Experience Modification</u> |
|-----------------------|--------------------------------|
| 10/30/25 to 10/30/26 | 1.00 |

We trust you will find the enclosed in order but should you have any questions please contact our office.

Sincerely,

Julie Kaiser

Julie Kaiser
Client Service Manager



Insurance | Risk Management | Consulting

March 4, 2026

New York State Department of Transportation
50 Wolf Road
Albany, NY 12232

Re: Insured - Verde Electric Corp - 89 Edison Avenue, Mount Vernon, NY 10550

General Liability/ Umbrella Insurance Rate Calculation Based on Sales:

| | | |
|---|----------------------------|-----------------------|
| General Liability (per \$100 of payroll) | \$30.65 | See below for support |
| Lead Umbrella (per \$100 of payroll) | \$5.50 | See below for support |
| First Umbrella (per \$100 of payroll) | \$4.00 | See below for support |
| Second Umbrella (per \$100 of payroll) | \$3.50 | See below for support |
| Total | \$43.65 \$40.15 | |
| Per \$100 of payroll | | |
| Verde Electric GL & Umbrella Rate | 43.65% 40.15% | |

General Liability

Insuring Company: Traveler Indemnity Company.

AM. Best Rating: A++XV (Admitted)

Policy Number: VTC2KCO3X459385IND25

Policy Expires: 10/31/2026

Limit of Liability:

General Aggregate: \$4,000,000

Products Completed Operations Aggregate: \$4,000,000

Personal & Advt. Injury: \$2,000 ,000

Each Occurrence: \$ 2,000,000

Damage to Rented Premise: \$300,000

Rate- \$30.65 per \$100 of Payroll



Insurance | Risk Management | Consulting

Excess Umbrella Liability

Insuring Company: Starr Indemnity & Liability Company Company.

AM. Best Rating: A++XV (Admitted)

Policy Number: 1100588039251

Policy Expires: 10/31/2026

Limit of Liability:

General Aggregate: \$3,000,000

Each Occurrence: \$3,000,000

Rate- \$5.50 per \$100 of Payroll

Excess Umbrella Second

Insuring Company: Berkley Casualty Company

AM. Best Rating: A+XV (Admitted)

Policy Number: BCS880013440

Policy Expires: 10/31/2026

Limit of Liability:

General Aggregate: \$7,000,000

Each Occurrence: \$7,000,000

Rate- \$4.00 per \$100 of Payroll

Excess Umbrella Third

Insuring Company: Zurich Insurance Company & Liberty Insurance Underwriting

AM. Best Rating: A+XV (Admitted) and A XV (Admitted)

Policy Number: A E C 7 1 3 0 5 7 0 - 0 3 and 1 0 0 0 5 7 0 2 1 6 0 2

Policy Expires: 10/31/2026

Limit of Liability:

General Aggregate: \$10,000,000



Insurance | Risk Management | Consulting

Each Occurrence: \$10,000,000

Rate- \$3.50 per \$100 of Payroll

Workers Compensation

Insuring Company: Charter Oak Fire Ins. Co. (Travelers)

AM. Best Rating: A++XV

Policy Number: UB4X4902572525H

Policy Expires: 10/31/2026

Limit of Liability:

Each Accident: Statutory Disease

Policy Limit: Statutory

Disease: Each Employee: Statutory

Exposure: Electrical Wiring Rate: \$12.38 per \$100 of Payroll: Conduit Rate - \$16.74 per \$100

Average Rate: \$14.56 per \$100 of Payroll (See Support Below)

| | Estimated Payroll | Rate per \$100 | Premium |
|-------------------|-----------------------|----------------|---------------------|
| Electrical Wiring | \$1,100,000.00 | 12.38% | \$136,111.80 |
| Conduit | \$1,300,909.00 | 16.74% | \$217,623.90 |
| Total: | \$2,400,000.00 | | \$353,735.70 |
| | | 14.56% | Blended Rate |

If you would like to speak with me directly please feel free to contact me. My email address is David_Brockmann@ajg.com; my office phone number is 518-533-6898 and my mobile phone number is 518- 330-1743.

David Brockmann

David Brockmann, Jr.
Area Vice President
Director of Construction Services
Arthur J. Gallagher Risk Management Services

Reset Form

NEW YORK STATE DEPARTMENT OF TRANSPORTATION COST ANALYSIS WORKSHEET (9/22)

Print Form

Contract D# **036472**

Change Order # **001**

Field Change Payment #

CO Item Qty **46**

Section 1 - Existing Contract Item

Use the Item Analysis Report and CONR 22 Composite Report in BI to fill out the below information. Follow Added Work Cost Analysis Decision Flow Chart.

Item Spec No

Unit Bid Price

Bid Qty

Current Contract Qty

Major Item

Minor Item

75% Threshold

Renegotiation Threshold

125% Threshold

(200% and \$5,000 over original contract amount)

High Bid Item (over 125%) Yes No

Section 2 - New Contract Item or Continuation of Existing Item

New Item Spec No **950.0401A**

Renegotiated Qty **46**

Contractor Quoted Unit Price **\$9,200.46**

Method Chosen:

- Original Bid Price Acceptable?
- Contractor agrees to work at the Original Contract Bid Price adjusted for documented changes in material costs, equipment rates, mobilization, and/or site conditions, and bid price is reasonable compensation for the quantity of added work: include letter from contractor, and supporting documentation for adjustments (need price analysis) on CO Header
- Weighted Average Price (WAP) Comparison (must have at least 3 contracts)

Pay Item Catalog Date Range to

PIC Qty Range to N/A

Regional WAP Statewide WAP

Printout of PIC w/ Qty Range, dates, prices attached?

- Comparison to Average of 3 Lowest Bidders (on contract, not item)

Average Price **\$0.00** Bidder 1

Bidder 2

Bidder 3

Printout of 3 Lowest Bidders on the Contract attached?

- Price Analysis

MURK 26/27 Price Analysis Worksheet attached and all documentation attached?

- Force Account Work (FAW)

FE (Force Estimate) Estimate of Labor, Materials, and Equipment work up included?

FAW (Final) Included with all MURK forms and documentation attached?

Project Conditions/Variance Explanation attached?

Signature *Katelyn A. Vito*

Date **Mar 25, 2026**

Reset Form

NEW YORK STATE DEPARTMENT OF TRANSPORTATION COST ANALYSIS WORKSHEET (9/22)

Print Form

Contract D# **036472**

Change Order # **001**

Field Change Payment #

CO Item Qty **-45**

Section 1 - Existing Contract Item

Use the Item Analysis Report and CONR 22 Composite Report in BI to fill out the below information. Follow Added Work Cost Analysis Decision Flow Chart.

Item Spec No **608.01050109**

Unit Bid Price **\$6,832.98**

Bid Qty **58**

Current Contract Qty **58**

Major Item

Minor Item

75% Threshold **43.5**

Renegotiation Threshold
(200% and \$5,000 over original contract amount)

125% Threshold **72.5**

High Bid Item (over 125%) Yes No

Section 2 - New Contract Item or Continuation of Existing Item

New Item Spec No

Renegotiated Qty

Contractor Quoted Unit Price

Method Chosen:

- Original Bid Price Acceptable?
- Contractor agrees to work at the Original Contract Bid Price adjusted for documented changes in material costs, equipment rates, mobilization, and/or site conditions, and bid price is reasonable compensation for the quantity of added work: include letter from contractor, and supporting documentation for adjustments (need price analysis) on CO Header
- Weighted Average Price (WAP) Comparison (must have at least 3 contracts)

Pay Item Catalog Date Range to

PIC Qty Range to N/A

Regional WAP Statewide WAP

Printout of PIC w/ Qty Range, dates, prices attached?

- Comparison to Average of 3 Lowest Bidders (on contract, not item)

Average Price **\$0.00**

Bidder 1

Bidder 2

Bidder 3

Printout of 3 Lowest Bidders on the Contract attached?

- Price Analysis

MURK 26/27 Price Analysis Worksheet attached and all documentation attached?

- Force Account Work (FAW)

FE (Force Estimate) Estimate of Labor, Materials, and Equipment work up included?

FAW (Final) Included with all MURK forms and documentation attached?

Project Conditions/Variance Explanation attached?

Signature *Katelyn A. Vito*

Date **Apr 27, 2026**

NEW YORK STATE DEPARTMENT OF TRANSPORTATION Agreed Price Worksheet - Prime Contractor

Contract: 8758.75 Item No.: 950.0402 Quantity: 2.00 Units: EA

Item Description : Colored Concrete for Type 9 Curb Ramps w/ Pro350 Sealer & Slip Resistant

(A) LABOR

| Trade | Reg Hours | Wage Rate | Cost | Fringe Hours | Fringe Rate | Cost |
|-------------------------------|-----------|-----------|-------------|--------------|-------------|-------------|
| 137 Operator Foreman | 16.00 | \$ 65.26 | \$ 1,044.16 | 16.00 | \$ 50.46 | \$ 807.36 |
| 60 Laborer Group 2 | 48.00 | \$ 50.71 | \$ 2,434.08 | 48.00 | \$ 34.82 | \$ 1,671.36 |
| 60 ACI Concrete Finisher Grp1 | 16.00 | \$ 56.27 | \$ 900.32 | 16.00 | \$ 35.14 | \$ 562.24 |
| 137 Operator Journeyman | 4.00 | \$ 62.07 | \$ 248.28 | 4.00 | \$ 50.14 | \$ 200.56 |
| | | | | | | |
| | | | | | | |
| | | | | | | |
| | | | | | | |

Wages **\$ 4,626.84**

Fringes **\$ 3,241.52**

If Fringes are paid directly to employee via cash or check, Enter value here:

\$ 0.00
Worker's Compensation Rate (%): **14.56 %**

Total of Wages and Fringes: **\$ 7,868.36**
 Workers Compensation: **\$ 673.67**
 Standard Labor Markup: **\$ 578.36**
 Fringe Benefit Markup: **\$ 0.00**
Labor Total: \$ 9,120.38

(The Contractor shall submit an insurance policy declaration / rate page from its insurer to validate the Workers Comp insurance rate based on an EMR of 1.0.)

(B) MATERIALS

| Description | Units | # of Units | Cost/Unit | Cost | Description | Units | # of Units | Cost/Unit | Cost |
|---------------------|-------|------------|-----------|----------|------------------|-------|------------|------------|------------|
| Colored Concrete | CY | 2.00 | \$314.04 | \$628.08 | HC Tiles | EA | 4.00 | \$133.23 | \$532.92 |
| Pro350 Sealer | PAIL | 0.50 | \$289.17 | \$144.59 | Granite Curb | LS | 1.00 | \$1,474.70 | \$1,474.70 |
| Slip-Resist Additiv | BOX | 0.50 | \$21.47 | \$10.73 | Class A Concrete | CY | 2.00 | \$171.00 | \$342.00 |
| Paint Supplies | LS | 0.50 | \$170.00 | \$85.00 | Asphalt | TON | 2.00 | \$91.00 | \$182.00 |

Materials Total: **\$3,400.02**

(C) EQUIPMENT

| Description | Hours | FHWA Rate | Cost | Description | Hours | FHWA Rate | Cost |
|--------------|-------|-----------|------------|-------------|-------|-----------|------|
| Pickup Truck | 16.00 | \$41.11 | \$657.76 | | | | |
| Box Truck | 16.00 | \$86.75 | \$1,388.00 | | | | |
| Rack Truck | 16.00 | \$86.75 | \$1,388.00 | | | | |
| Komatsu PC78 | 4.00 | \$55.16 | \$220.64 | | | | |

Equipment Total: **\$ 3,654.40**

(D) SERVICES

| Description / Type | # of Units | Cost / Unit | Cost | Description / Type | # of Units | Cost / Unit | Cost |
|--------------------|------------|-------------|------|--------------------|------------|-------------|------|
| | | | | | | | |
| | | | | | | | |

Services Total:

(E) OVERHEAD & PROFIT

| | OH & Profit % | Cost |
|--------------------------------------|---------------|--------------------|
| Labor, Materials, & Equipment Total: | 20.00 | \$ 3,234.96 |
| Services: | | \$ 0.00 |

Overhead & Profit Total: **\$ 3,234.96**

(F) INSURANCE

Enter rate here if based on payroll

Payroll Based Cost Basis **40.15 %**

Enter rate here if based on sales

Sales Based Cost Basis **\$ 0.00**

Insurance Total: **\$ 1,857.68**

Item Total: **\$ 21,267.44**

Unit Price: **\$ 10,633.72** per **EA**

Robert Craig Robert Craig 3-12-26 Arlisa McGrath *Arlisa McGrath* 4/9/26
 Contractor's Rep Name Signature Date Engineer-in-Charge's Name Signature Date

VERDE ELECTRIC CORP LABOR RATE BREAKDOWN

EFFECTIVE DATES:

FROM: 3/4/2025
TO: 3/3/2026

TRADE CLASSIFICATION:

OPERATORS OS FOREMAN

UNION:

OPERATING ENGINEERS

LOCAL NO:

137

| | | Straight Time | Overtime & Saturday | Sunday |
|---|-------------|------------------|---------------------|------------------|
| 1 HOURLY RATE | | | | |
| | | \$ 65.26 | \$ 97.89 | \$ 130.52 |
| 2 FRINGES: | | | | |
| | RATE | | | |
| Welfare | \$21.40 | \$ 21.40 | \$21.40 | \$ 21.40 |
| Vacation | \$3.20 | \$ 3.20 | \$ 3.20 | \$ 3.20 |
| Savings/PSL | \$1.10 | \$ 1.10 | \$ 1.10 | \$ 1.10 |
| Pension | \$5.18 | \$ 5.18 | \$ 5.18 | \$ 5.18 |
| Apprenticeship | \$1.30 | \$ 1.30 | \$ 1.30 | \$ 1.30 |
| National Training | \$0.10 | \$ 0.10 | \$ 0.10 | \$ 0.10 |
| Annuity | \$8.50 | \$ 8.50 | \$ 8.50 | \$ 8.50 |
| IAF | \$0.50 | \$ 0.50 | \$ 0.50 | \$ 0.50 |
| Supplemental Dues | 3.75% | \$ 2.45 | \$ 3.67 | \$ 4.89 |
| PAC | \$0.05 | \$ 0.05 | \$ 0.05 | \$ 0.05 |
| LMCT | \$1.00 | \$ 1.00 | \$ 1.00 | \$ 1.00 |
| ** Holiday | \$5.68 | \$ 5.68 | \$ 5.68 | \$ 5.68 |
| TOTAL FRINGES: | | \$ 50.46 | \$ 51.68 | \$ 52.90 |
| 3 PAYROLL TAXES & INSURANCE | | | | |
| | RATE | | | |
| FICA (Social Security & Medicare) | 7.65% | \$ 4.99 | \$ 7.49 | \$ 9.98 |
| Federal Unemployment | 0.60% | \$ 0.39 | \$ 0.59 | \$ 0.78 |
| Metro Tax | 0.34% | \$ 0.22 | \$ 0.33 | \$ 0.44 |
| New York Unemployment | 8.33% | \$ 5.44 | \$ 8.15 | \$ 10.87 |
| Workers Comp | 7.80% | \$ 5.09 | \$ 5.09 | \$ 5.09 |
| General Liability | 15.50% | \$ 10.12 | \$ 15.17 | \$ 20.23 |
| TOTAL PAYROLL TAXES & INSURANCE: | | \$ 26.25 | \$ 36.83 | \$ 47.40 |
| 4 TOTAL LABOR RATE, FRINGES, TAXES & INSURANCE | | | | |
| | | \$ 141.96 | \$ 186.40 | \$ 230.83 |

** Holiday computed as 80 hour cost divided by 1,920 (est. 48 week work year)

VERDE ELECTRIC CORP LABOR RATE BREAKDOWN

EFFECTIVE DATES:

FROM: 3/30/2025
 TO: 3/28/2026

TRADE CLASSIFICATION:

GROUP II

UNION:

HVY, HWY, UTILITY

LOCAL NO:

60

| | | Straight Time | Overtime & Saturday | Sunday |
|--|-------------|------------------|---------------------|------------------|
| 1 HOURLY RATE | | | | |
| | | \$ 50.71 | \$ 76.07 | \$ 101.42 |
| 2 FRINGES: | | | | |
| | RATE | | | |
| Welfare | \$10.63 | \$ 10.63 | \$ 10.63 | \$ 10.63 |
| Pension | \$11.15 | \$ 11.15 | \$ 11.15 | \$ 11.15 |
| Annuity | \$6.00 | \$ 6.00 | \$ 6.00 | \$ 6.00 |
| Apprentice & Training | \$1.10 | \$ 1.10 | \$ 1.10 | \$ 1.10 |
| Labor Management | \$0.95 | \$ 0.95 | \$ 0.95 | \$ 0.95 |
| LECET | \$0.15 | \$ 0.15 | \$ 0.15 | \$ 0.15 |
| NY Health and Safety | \$0.10 | \$ 0.10 | \$ 0.10 | \$ 0.10 |
| IAF | \$0.50 | \$ 0.50 | \$ 0.50 | \$ 0.50 |
| ** Holiday | \$4.24 | \$ 4.24 | \$ 4.24 | \$ 4.24 |
| TOTAL FRINGES: | | \$ 34.82 | \$ 34.82 | \$ 34.82 |
| 3 PAYROLL TAXES & INSURANCE | | | | |
| | RATE | | | |
| FICA (Social Security & Medicare) | 7.65% | \$ 3.88 | \$ 5.82 | \$ 7.76 |
| Federal Unemployment | 0.60% | \$ 0.30 | \$ 0.46 | \$ 0.61 |
| Metro Tax | 0.34% | \$ 0.17 | \$ 0.26 | \$ 0.34 |
| New York Unemployment | 8.33% | \$ 4.22 | \$ 6.33 | \$ 8.44 |
| Workers Comp | 7.80% | \$ 3.96 | \$ 3.96 | \$ 3.96 |
| General Liability | 15.50% | \$ 7.86 | \$ 11.79 | \$ 15.72 |
| TOTAL PAYROLL TAXES & INSURANCE: | | \$ 20.39 | \$ 28.61 | \$ 36.83 |
| 4 TOTAL LABOR RATE, TAXES & INSURANCE | | | | |
| | | \$ 105.92 | \$ 139.49 | \$ 173.07 |

** Holiday computed as 80 hour cost divided by 1,920 (est. 48 week work year)

VERDE ELECTRIC CORP LABOR RATE BREAKDOWN

EFFECTIVE DATES:

FROM: 3/30/2025
TO: 3/28/2026

TRADE CLASSIFICATION:

GROUP I

UNION:

HVY, HWY, UTILITY

LOCAL NO:

60

| | | Straight Time | Overtime & Saturday | Sunday |
|--|-------------|------------------|------------------------|------------------|
| 1 HOURLY RATE | | | | |
| | | \$ 56.27 | \$ 84.41 | \$ 112.54 |
| 2 FRINGES: | | | | |
| | RATE | | | |
| Welfare | \$10.63 | \$ 10.63 | \$ 10.63 | \$ 10.63 |
| Pension | \$11.15 | \$ 11.15 | \$ 11.15 | \$ 11.15 |
| Annuity | \$6.00 | \$ 6.00 | \$ 6.00 | \$ 6.00 |
| Apprentice & Training | \$1.10 | \$ 1.10 | \$ 1.10 | \$ 1.10 |
| Labor Management | \$0.95 | \$ 0.95 | \$ 0.95 | \$ 0.95 |
| LECET | \$0.15 | \$ 0.15 | \$ 0.15 | \$ 0.15 |
| NY Health and Safety | \$0.10 | \$ 0.10 | \$ 0.10 | \$ 0.10 |
| IAF | \$0.50 | \$ 0.50 | \$ 0.50 | \$ 0.50 |
| ** Holiday | \$4.56 | \$4.56 | \$ 4.56 | \$ 4.56 |
| TOTAL FRINGES: | | \$ 35.14 | \$ 35.14 | \$ 35.14 |
| 3 PAYROLL TAXES & INSURANCE | | | | |
| | RATE | | | |
| FICA (Social Security & Medicare) | 7.65% | \$ 4.30 | \$ 6.46 | \$ 8.61 |
| Federal Unemployment | 0.60% | \$ 0.34 | \$ 0.51 | \$ 0.68 |
| Metro Tax | 0.34% | \$ 0.19 | \$ 0.29 | \$ 0.38 |
| New York Unemployment | 8.33% | \$ 4.68 | \$ 7.03 | \$ 9.37 |
| Workers Comp | 7.80% | \$ 4.39 | \$ 4.39 | \$ 4.39 |
| General Liability | 15.50% | \$ 8.72 | \$ 13.08 | \$ 17.44 |
| TOTAL PAYROLL TAXES & INSURANCE: | | \$ 22.63 | \$ 31.75 | \$ 40.87 |
| 4 TOTAL LABOR RATE, TAXES & INSURANCE | | | | |
| | | \$ 114.04 | \$ 151.30 | \$ 188.55 |

** Holiday computed as 80 hour cost divided by 1,920 (est. 48 week work year)

VERDE ELECTRIC CORP LABOR RATE BREAKDOWN

EFFECTIVE DATES:

FROM: 3/4/2025
 TO: 3/3/2026

TRADE CLASSIFICATION:

OPERATOR JOURNEYMAN

UNION:

OPERATING ENGINEERS

LOCAL NO:

137

| | | Straight Time | Overtime & Saturday | Sunday |
|---|-------------|---------------|---------------------|-----------|
| 1 HOURLY RATE | | | | |
| | | \$ 62.07 | \$ 93.11 | \$ 124.14 |
| 2 FRINGES: | | | | |
| | RATE | | | |
| Welfare | \$21.40 | \$ 21.40 | \$ 21.40 | \$ 21.40 |
| Vacation | \$3.20 | \$ 3.20 | \$ 3.20 | \$ 3.20 |
| Savings/PSL | \$1.10 | \$ 1.10 | \$ 1.10 | \$ 1.10 |
| Pension | \$5.18 | \$ 5.18 | \$ 5.18 | \$ 5.18 |
| Apprenticeship | \$1.30 | \$ 1.30 | \$ 1.30 | \$ 1.30 |
| National Training | \$0.10 | \$ 0.10 | \$ 0.10 | \$ 0.10 |
| Annuity | \$8.50 | \$ 8.50 | \$ 8.50 | \$ 8.50 |
| IAF | \$0.50 | \$ 0.50 | \$ 0.50 | \$ 0.50 |
| Supplemental Dues | 3.75% | \$ 2.33 | \$ 3.49 | \$ 4.66 |
| PAC | \$0.05 | \$ 0.05 | \$ 0.05 | \$ 0.05 |
| LMCT | \$1.00 | \$ 1.00 | \$ 1.00 | \$ 1.00 |
| ** Holiday | \$5.49 | \$ 5.49 | \$ 5.49 | \$ 5.49 |
| TOTAL FRINGES: | | \$ 50.14 | \$ 51.31 | \$ 52.47 |
| 3 PAYROLL TAXES & INSURANCE | | | | |
| | RATE | | | |
| FICA (Social Security & Medicare) | 7.65% | \$ 4.75 | \$ 7.12 | \$ 9.50 |
| Federal Unemployment | 0.60% | \$ 0.37 | \$ 0.56 | \$ 0.74 |
| Metro Tax | 0.34% | \$ 0.21 | \$ 0.32 | \$ 0.42 |
| New York Unemployment | 8.33% | \$ 5.17 | \$ 7.76 | \$ 10.34 |
| Workers Comp | 7.80% | \$ 4.84 | \$ 4.84 | \$ 4.84 |
| General Liability | 15.50% | \$ 9.62 | \$ 14.43 | \$ 19.24 |
| TOTAL PAYROLL TAXES & INSURANCE: | | \$ 24.96 | \$ 35.03 | \$ 45.09 |
| 4 TOTAL LABOR RATE, FRINGES, TAXES & INSURANCE | | | | |
| | | \$ 137.18 | \$ 179.44 | \$ 221.70 |

** Holiday computed as 80 hour cost divided by 1,920 (est. 48 week work year)



OFFER

Cranesville Block Co., Inc.
 1250 Riverfront Center
 Amsterdam, NY 12010
 www.cranesville.com

Phone: 518-684-6000
 Dispatch: 518-684-6085
 Sales: 518-684-6078
 Sales Fax: 518-684-0128
 Credit: 518-684-6004

Ready Mixed Concrete – Aggregates – Masonry Units – Precast – Masonry Supplies

Customer Name Verde Electric
 Attention Anthony Mauriello
 Office Phone (914) 664-7000
 Cell Phone (914) 652-3908
 Email amauriello@verdeelectric.com
 Fax (914) 668-7997
 Yards 800
 Quote Number 00011972

Project Name Broadway Improvements Newburgh
 Project Address Robinson Ave
 Project Newburgh, NY
 Address(Cont'd)
 Quote Date 8/8/2025
 Expiration Date 12/31/2025
 Project Salesman Bill Cobey
 Salesman Mobile 845-313-0626
 Salesman Email wcobey@cranesville.com
 Sales Assoc. Patti Bieniek
 Sales Assoc. Phone 518-684-6119
 Sales Assoc. Email pbieniek@cranesville.com

| Quantity | Product | Line Item Description | Sales Price | UM |
|----------|------------------|--|-------------|----|
| 800.00 | Class D Concrete | Straight Cement for colored concrete (Included 1.5 lbs. fiber for sidewalks) | \$196.45 | CY |

***Due to the potential disruption in the cement supply chain, we reserve the right to requote as necessary.**

Above mixes are designed to have a 2"- 4" slump.
 If a 4"- 6" slump is required a Midrange will need to be used at additional price listed below
 If a 7"-9" slump is required a Super Plasticizer will need to be used at additional price listed below
 Plants are NYSDOT approved; not NRMCA.

Additional Information:

SIKA COLOR #14 GRAY (4 BAGS/YARD) \$109.50/CY

Please see the Terms & Conditions on the last page of this Offer.
MINIMUM OF A 6% INCREASE ON ALL BELOW PRODUCTS FOR EACH SUBSEQUENT YEAR.

Class D base price w/ fiber \$196.45/CY

Sample load CID 11 CY @ \$196.45

sika color 11 CY @ \$109.50

Environmental Charge 1 ea @ \$13.99

Color washout 1 ea @ \$50.00

fuel surcharge 1 ea @ \$25.00

Total: \$3,454.44

deduct fiber -12.45 = ~~\$314.04 / CY~~
 = \$301.59



OFFER

Cranesville Block Co., Inc.
 1250 Riverfront Center
 Amsterdam, NY 12010
 www.cranesville.com

Phone: 518-684-6000
 Dispatch: 518-684-6085
 Sales: 518-684-6078
 Sales Fax: 518-684-0128
 Credit: 518-684-6004

Ready Mixed Concrete – Aggregates – Masonry Units – Precast – Masonry Supplies

| Additional Products and Services – Mont / Fish / Lib | | | | | |
|---|---------------|--|-------------|-------------------------------|-------------|
| Environmental Surcharge (mandatory) | \$13.99 /load | Small Stone | \$2.75 /cy | Non-Chloride 1% | \$7.15 /cy |
| Fuel Surcharge (mandatory) (subject to change) | \$25.00/load | Fiber (1 lb per cy) | \$9.25 /cy | Non-Chloride 2% | \$11.65 /cy |
| Color Washout | \$50.00 /load | Fiber (1.5 lb per cy) | \$12.45 /cy | Calcium 1% | \$5.55 /cy |
| Saturday Delivery | \$75.00 /load | Mid-Range Water Reducer | \$5.00 /cy | Calcium 2% | \$10.30 /cy |
| Truck Time (Overtime) Charge (per minute) | \$2.00 /min | High Range Water Reducer (Super Plasticizer) | \$9.25 /cy | Retarder | \$5.55 /cy |
| Cold Weather (Exact weather subject to ACI standards) | \$12.50/cy | Corrosion Inhibitor | Inquire | Moisture Vapor Reducing Admix | Inquire |
| Ice (hot weather Concrete) | Inquire | | | | |

| Terms and Conditions | |
|--|---|
| Any purchase order sent by Buyer and not signed by an authorized representative of Seller will be invalid, regardless of commencement of delivery. | |
| <ul style="list-style-type: none"> * This offer is expressly limited to and expressly made conditional on buyer's acceptance of these terms and conditions and (a copy of the Consolidated Joint Application for Extension of Credit available at http://ec.cranesville.com/pdf/files/cre-21-japp.pdf). Seller objects to any different terms and conditions contained in any purchase order or any other document sent by buyer. Seller will not accept terms of any purchase order, which incorporate by reference terms and conditions of a separate and distinct agreement. * All invoices are due net thirty (30) days from delivery or sale; Invoices remaining delinquent beyond thirty (30) days shall bear an 18% per annum finance charge. * Seller's delivery of goods to buyer constitutes buyer's acceptance of this offer in the absence of buyer's written signature. * Seller's warranty limited to full refund of purchase price. * This offer is not contingent upon strikes, riots, authority of law, acts of God and/or other causes beyond our control. Access to the project and individual delivery locations must be such that normal drive ready mixed, boom, tanker, fit-axle or tractor trailer trucks can maneuver under their own power at all times. The Seller reserves the right to stop deliveries if roadways or approaches are unsatisfactory to him/her. The buyer assumes all liability for damage to sidewalks, driveways or other property beyond the curb line and agrees to indemnify the Seller against all liability loss and expenses incurred as a result of such delivering including damage to Seller's equipment and loss of time. * The products have been designed to attain the indicated compressive strengths in accordance with recognized testing methods and standards. Field results may differ substantially due to variables such as waiting time, placing methods, weather, handling after placement, addition of outside materials by buyer or request of buyer, such as water, and other variables beyond the control of the Seller. The Seller hereby disclaims any liability and/or warranty, expressed or implied should the buyer not use proper testing, placing and curing methods (ACI-ASTM). Upon delivery, it is the buyer's responsibility to confirm the correct product or mix has been delivered. There will be no credit or adjustment to billing for incorrect material incorporated into the work. | <ul style="list-style-type: none"> * Sales tax will be applied to Seller Invoice(s) unless appropriate documentation is received before ordering product. * Prices are based on full truckloads (7+CY). A short load will be charged on orders less than 7 yds (Contact sales for a copy of the rates). A balance on a plus order is one load of ten yards or less. * Heating or cooling of concrete is not included in product price. * If color is used on any job, an environmentally approved location must be available for a truck to rinse. * Hours of operation Monday - Friday 7:00 AM- 4:30 PM Saturday 8 AM - 12 PM. Contact sales for deliveries outside of these hours. * All products that are ordered and are not listed on this quote will be billed at the standard price. * Delivery times and truck spacing are targets Seller strives for but does not guarantee due to the demands of the industry. * Truck time will be charged after the allotted 4 minutes per yard, per truck, at the rate set forth in the "Additional Products and Services" schedule. Truck time is calculated, by truck, "At Job" until "Stop Four." * All offered prices are subject to price increase(s) due to cement and/or fuel cost increases. * The above pricing is based on the project's total yardage and specified mixes. Seller and other material producing companies reserve the right to re-price based on changes in quantity and/or mix, or extraneous factors. All quoted products are standard mix designs unless specifications have been provided prior to quotation. * Waiver of Consequential Damages: Purchaser, for good and valuable consideration, and as a condition of purchase, waives against Seller any and all damages arising directly, or as a consequence of, Seller providing defective or non-conforming goods. Such waiver shall include damages arising as a direct or indirect result of costs or property damage, to adjoining work caused or created by non-conforming or defective product provided by Seller. * The "Expiration Date" includes all terms and pricing listed. Standard pricing will apply thereafter. |

Price not enforceable by Buyer if not signed within 15 days of receipt. Please sign offer and return before ordering.

ACCEPTED BY:

DATE:

This is the last page of this Offer.



ACCOUNT MANAGER: HEATHER SCHEER
 HEATHER.SCHEER@WHITECAP.COM
 860-573-8566

CUSTOMER: VERDE ELECTRIC
 NAME: ANTHONY MAURIELLO
 JOB: BROADWAY NEWBURGH PTS

2025-08-06 Whitecap 18x36" Bluestone

| Description | Packaging | Item | Each Unit (ea) | QTY | Total |
|--------------------------------------|----------------|--------|----------------|-----|--------------|
| 18"X36" Bluestone- Rigid Black | 18" x 36" | 599712 | \$ 270.97 | 6 | \$ 1,625.82 |
| 18"X36" Bluestone- Rigid Blue | 18" x 36" | 599714 | \$ 270.97 | 6 | \$ 1,625.82 |
| 18"X36" Bluestone- Rigid Green | 18" x 36" | 599716 | \$ 270.97 | 6 | \$ 1,625.82 |
| 18"X36" Bluestone- Flex Black | 18" x 36" | 599711 | \$ 270.97 | 2 | \$ 541.94 |
| 18"X36" Bluestone Flex Blue | 18" x 36" | 599713 | \$ 270.97 | 2 | \$ 541.94 |
| Bluestone Texture Touch-up Skin | 18" x 18" | 599625 | \$ 104.89 | 2 | \$ 209.78 |
| Bluestone 9" Texture Roller Sleeve | 9" x 3.25" | 600017 | \$ 88.80 | 2 | \$ 177.60 |
| 2" Chisel | 2" x 7.5" | 618415 | \$ 18.34 | 2 | \$ 36.69 |
| 4" Chisel | 4" x 8" | 618416 | \$ 29.94 | 2 | \$ 59.89 |
| 8" Chisel | 8" x 8" | 618417 | \$ 32.99 | 2 | \$ 65.98 |
| 3/16" Touch-Up Wheel | 13.5" x 2.5" | 600666 | \$ 64.21 | 2 | \$ 128.42 |
| Perma-Cast® Clear Liquid Release | 5 Gal. | 619060 | \$ 138.14 | 72 | \$ 9,946.08 |
| SikaCem®-100 PRO 350® | 5 Gal. | 761327 | \$ 289.17 | 37 | \$ 10,699.29 |
| Clear Guard® Slip-Resistant Additive | Box of 6-1 lb. | 618584 | \$ 21.57 | 37 | \$ 798.05 |

Two Sets

Notes:
 Stamp Pattern # S4210
 Recommended Contractor Stamp Set: 9 Rigid, 2 Flex, 1 Skin, 1 Roller Sleeve
 Suggested Touch-Up / Detail Tools- Chisels: 2", 4", 8", & 12" Touch-up Wheel: 3/16"

Liquid Release Assumes 750 sf./ pail
 Lithochrome Wax assumes 200 Sf/Gal
 Pro 350 assumes 300-400 sq. ft./gal.



Mount Ple... 10PM

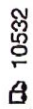

10532

What can we help you find today?



Shop All

Wooster

9 in. x 1/2 in. Pro Surpass Shed-Resistant Knit High-Density Fabric Roller Cover Applicator/Tool (3-Pack)

★★★★★ (1887) [Questions & Answers \(20\)](#)



RESEALABLE BAG



BULK PRICE AVAILABLE
\$12.48

Buy 4 or more \$10.61

Buy 4 or More, Get 15% Off

0 of 4 items

15% Off

Add 4 more to quality

[Shop This Offer](#)

- Fast results
- Shed-resistant knit
- Even coverage
- [View More Details](#)

Mount Pleasant Store

✓ 46 in stock Aisle 36, Bay 006

Package Quantity: 3

1

Nap Size/Thickness (in.): 1/2

Product Width (in.): 9 in



Mount Ple... 10PM 10532 What can we help you find today?



Shop All

Internet # 100187725 Model # D0R0550000 Store SKU # 1000022322

... / Paint / Paint Supplies / Paint Roller Extension Poles / Wooster Paint Roller Extension Poles

Top Rated

Wooster

Sherlock 4 ft. - 8 ft. Adjustable Extension Pole

★★★★★ (2040) Questions & Answers (47)

\$27.48

Pay \$2.48 after \$25 OFF your total qualifying purchase upon opening a new card.



Apply for a Home Depot Consumer Card



Buy 4 or More, Get 15% Off

0 of 4 items

15% Off

Add 4 more to qualify

[Shop This Offer](#)

- Thumb lever locks in 6 in. increments to adjust pole length
- Threaded tip fits most roller frames and tools
- Sturdy and durable
- [View More Details](#)

Mount Pleasant Store

✓ 35 in stock Aisle 36, Bay SC1

Minimum length (ft.): 4

Maximum length (ft.): 8





Mount Ple... 10PM 10532

What can we help you find today?



Best Seller

9 in. Heavy Duty 5-Wire Paint Roller Frame

★★★★★ (1145) Questions & Answers (7)

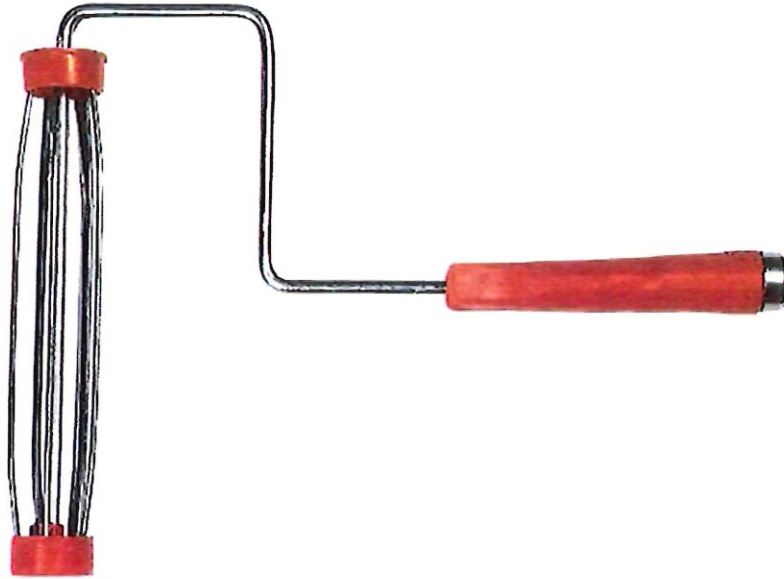

Hover Image to Zoom

\$448



- For use with all standard 9" paint roller covers
- 5-wire cage durably crafted with sturdy steel
- Threaded handle end is compatible with most extension poles
- [View More Details](#)

Mount Pleasant Store

✓ 300 in stock Aisle 36, Bay 008

Pickup at

[Mount Pleasant](#)

Delivering to [10532](#)

Pickup Today
300 in stock
FREE

Delivery Tomorrow
304 available
FREE

[Check Nearby Stores](#)

[Delivery Details](#)

Order within **5 hrs 57 mins** to get it by **Tomorrow**



Get it delivered Today for \$2.99. Schedule your delivery in checkout.

One-Time Purchase

9 in. Metal Paint Roller Tray

★★★★★ (991) Questions & Answers (3)

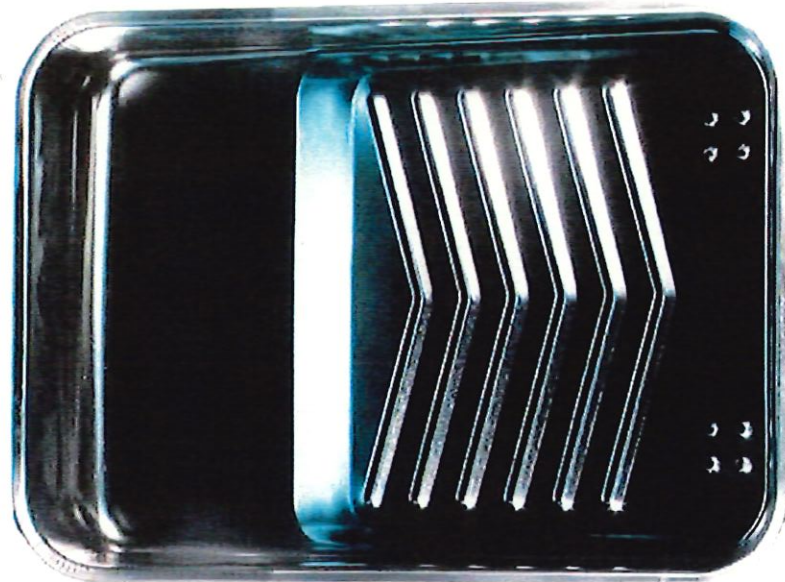

Hover Image to Zoom

\$3.98



- Designed for use with standard 9 in. roller covers and frames
- Made with solvent-resistant metal for durability
- Holds up to 1 quart paint or stain
- [View More Details](#)

Mount Pleasant Store

✓ 111 in stock Aisle 36, Bay 008

Pickup at

[Mount Pleasant](#)

Delivering to [10532](#)

Pickup
Today
111 in stock
FREE

Delivery
Tomorrow
428 available
FREE

[Check Nearby Stores](#)

[Delivery Details](#)



Get it delivered Today for \$2.99. Schedule your delivery in checkout.



1 +

➔ Add to Cart



Pay in 4 interest-free payments on purchases of \$30-\$t.500 with **PayPal**. [Learn more](#)

[Share](#) [Print](#)

WHITE CAP ON ACCOUNT



511 - Newington CT (AHH) (PZ10)
 91 Holmes Rd
 Newington, CT, 06111
 (860) 665-9400

QUOTE

68680989

**THIS IS A QUOTE ONLY DO NOT SHIP OR
 TENDER FUNDS**

Sold To: 10000215303
 VERDE ELECTRIC
 89 EDISON AVENUE
 MT VERNON, NY, 10550

Ship To : Broadway Traffic Signal Improvements,10005427450
 BROADWAY
 NEWBURGH, NY, 12550
Job Site Contact: anthony mauriello
Job Site Phone:
Map #:

10:44 AM

Ordered By: GEORGE CARUSO

Contact Phone:

| Quote Number | | Quote Date | Valid Until | Request Date | Sales Person | |
|--------------|--------------|--|--------------|-----------------|--------------|-------------|
| 68680989 | | 09/29/2025 | 10/06/2025 | 09/29/2025 | Scheer, H | |
| Terms | | Shipping Method | Quote Name | Customer PO | Created By | |
| N30D | | 10. WCD Common Carrier | ADA TILES | ADA TILES | Scheer, H | |
| SEQ | Part# H/M | Description | Ord Quantity | U/M Unit WT | Price COO | Amount |
| 10 | 546CI230WSPA | 24"X30" PATINA CAST IRON WET SET TUFTILE | 116 | EA 47.77 LBS | \$133.23 | \$15,454.68 |
| 20 | SHIPPING | SHIPPING AND HANDLING | 1 | EA 0 LBS | \$570.00 | \$570.00 |

| | |
|-------------------------------|--------------------|
| Shipped amount | \$16,024.68 |
| Order charges | \$0.00 |
| Tax amount | \$0.00 |
| Lumber Tax rate/amount | 1.00% |
| Quote total | \$16,024.68 |

Shipped Weight: 5,541.32 Customer acceptance signature: _____ Date : _____

ALL ITEMS AND QUANTITIES REQUIRE CUSTOMER REVIEW AND APPROVAL
AVAILABILITY AND LEAD TIMES ARE SUBJECT TO CHANGE
SPECIAL ORDERED ITEMS ARE SUBJECT TO MANUFACTURER APPROVAL PRIOR TO RETURN.
QUOTE IS SUBJECT TO EXPIRATION AS INDICATED IN THE ABOVE 10/06/2025 DATE.

The White Cap Family of Brands includes All-Tex Waterproofing Solutions, Harmac, Kenseal, Marvel Building & Masonry Supply, MASONPRO, and Williams Equipment & Supply. Learn more at About.WhiteCap.com.

Note: Due to volatility in the steel market from the recent Section 232 decision, domestic supply constraints and active trade negotiations, pricing is subject to change on a daily basis. Please review your pricing and contact your sales associate immediately to secure products and pricing.

WHITE CAP RESERVES THE RIGHT TO ADJUST PRICES TO REFLECT THE IMPACT OF ANY TARIFFS, DUTIES, OR SIMILAR GOVERNMENTAL CHARGES IMPOSED OR INCREASED AFTER THE DATE OF THIS QUOTE BUT PRIOR TO EXPIRATION.



OFFER

Cranesville Block Co., Inc.
 1250 Riverfront Center
 Amsterdam, NY 12010
 www.cranesville.com

Phone: 518-684-6000
 Dispatch: 518-684-6085
 Sales: 518-684-6078
 Sales Fax: 518-684-0128
 Credit: 518-684-6004

Ready Mixed Concrete – Aggregates – Masonry Units – Precast – Masonry Supplies

Customer Name Verde Electric
 Attention Tony .
 Office Phone (914) 664-7000
 Cell Phone 845-337-9903
 Email albtomy@gmail.com
 Fax (914) 668-7997
 Yards 940
 Quote Number 00010099

Project Name Newburgh Broadway Recycling
 Project Address lbd
 Project Newburgh, NY
 Address(Cont'd)
 Quote Date 2/24/2025
 Expiration Date 12/31/2025
 Project Salesman Bill Cobey
 Salesman Mobile 845-313-0626
 Salesman Email wcobey@cranesville.com
 Sales Assoc. Patti Bieniek
 Sales Assoc. Phone 518-684-6119
 Sales Assoc. Email pbieniek@cranesville.com

| Quantity | Product | Line Item Description | Sales Price | UM |
|----------|------------------|--|-------------|----|
| 140.00 | Class A Concrete | | \$171.00 | CY |
| 690.00 | Class D Concrete | Excludes fiber or water reducer | \$184.00 | CY |
| 1.00 | Class D Concrete | Includes 1.5 lbs fiber and water reducer (sidewalks) | \$199.45 | CY |

***Due to the potential disruption in the cement supply chain, we reserve the right to requote as necessary.**

Above mixes are designed to have a 2"- 4" slump.

If a 4"- 6" slump is required a Midrange will need to be used at additional price listed below
 If a 7"-9" slump is required a Super Plasticizer will need to be used at additional price listed below
 Plants are NYSDOT approved; not NRMCA.

Please see the Terms & Conditions on the last page of this Offer.

MINIMUM OF A 6% INCREASE ON ALL BELOW PRODUCTS FOR EACH SUBSEQUENT YEAR.



Peckham Industries, Inc.
 172 Prospect Hill Rd, Brewster, NY 10509
 (914) 949-2000

Job Description: BROADWAY TRAFFIC SIG IMP - NEWBURGH

*** PRICING IS ONLY VALID FOR 30 DAYS FROM QUOTE DATE ***

| | | | |
|----------------------|--------------------|------------------------|---------------------------------|
| Quote Date: | 02/10/2025 | Customer: | Verde Electric Maintenance Inc. |
| Job Completion Date: | | | 89 Edison Avenue |
| Quote Expiration: | 03/02/2025 | | Mount Vernon, NY, 10550 |
| Project Location: | | Project Contact Name: | TONY MAVRA |
| Asphalt Index Type: | | Project Phone No: | 845-337-9903 |
| Asphalt Base Price: | | Project Fax No: | |
| Salesman Information | | Project Contact Email: | ALBTONY@GMAIL.COM |
| Name: | Joe Tetz | Job No: | |
| Phone: | | P.O. No: | |
| Mobile: | | Property Owner | |
| Email: | jtetz3@peckham.com | Name: | |
| Quote ID: | Q-11772 | Street: | |
| | | City, State Zip: | |

| QTY | UOM | Product Description / DOT Item Code | Unit Price | | Extended Total | |
|------|------|--|----------------------------|-----------|----------------|-----------|
| | | | FOB | Delivered | FOB | Delivered |
| 1 | Tons | 4900 - Tipping Fee Concrete Middletown HMA | \$12.00 | - | \$12.00 | - |
| 1 | Tons | 4898 - TIPPING FEE MILLINGS Middletown HMA | \$12.00 | - | \$12.00 | - |
| 85 | Tons | 1204 - SUPERPAVE 19 MM (WMA) - 64S-22 Middletown HMA | \$91.00 | - | \$7,735.00 | - |
| 88 | Tons | 1208 - SUPERPAVE 9.5 MM (WMA) 64S-22 Middletown HMA | \$94.00 | - | \$8,272.00 | - |
| 1650 | Tons | 1300 - 304. - ITEM 4 Chester Quarry | \$16.50 | - | \$27,225.00 | - |
| 260 | Tons | 1306 - 203.07 SELECT GRANULAR FILL (M Chester Quarry | \$16.50 | - | \$4,290.00 | - |
| | | | Total | | \$47,546.00 | - |
| | | | Total including tax | | \$51,409.11 | - |

special note

SUPERPAVE QUOTED WITH 64S-22 AND WMA IF 64E OIL IS NEEDED PLEASE ADD 9.00 PER TON.
 ONLY CLEAN MILLINGS WILL BE ACCEPTED

ALL PRICING EXPIRES 12/31/25

Salesperson Signature: _____

Customer Signature: _____

Name: _____ Date: _____

Name: _____ Date: _____

WHITE CAP[®] ON ACCOUNT



511 - Newington CT (AHH) (PZ10)
 91 Holmes Rd
 Newington, CT, 06111
 (860) 665-9400

QUOTE

67755862

THIS IS A QUOTE ONLY DO NOT SHIP OR
 TENDER FUNDS

Sold To: 10000215303
 VERDE ELECTRIC
 89 EDISON AVENUE
 MT VERNON, NY, 10550

Ship To: Broadway Traffic Signal Improvements,10005427450
 BROADWAY
 NEWBURGH, NY, 12550
 Job Site Contact: ANTHONY ANTHONY
 Job Site Phone: 914-652-3908
 Map #:

12:45 PM

Ordered By: ANTHONY ANTHONY

Contact Phone: 914-6523908

| Quote Number | Quote Date | Valid Until | Request Date | Sales Person | | |
|--------------|-----------------|---|--------------|-----------------|--------------|-------------|
| 67755862 | 08/12/2025 | 08/19/2025 | 08/12/2025 | Scheer, H | | |
| Terms | Shipping Method | Quote Name | Customer PO | Created By | | |
| N30D | 2. Our Truck | BROADWAY | broadway | Scheer, H | | |
| SEQ | Part# H/M | Description | Ord Quantity | U/M Unit WT | Price COO | Amount |
| 10 | 434666G510 | 6"X6" W2.9 6GA 5'X10' WIRE MESH MAT | 1100 | EA 20.69 LBS | \$17.43 | \$19,173.00 |
| 20 | 199EB124010 | 1/2"X4"X10' FIBER EXPANSION BOARD 100FT/BUNDLE | 7500 | FT .32 LBS | \$0.38 | \$2,850.00 |
| 30 | 505VC12 | 1/2"X10' TOP VOID CAP SOLD/FOOT | 7400 | FT .08 LBS | \$0.37 | \$2,738.00 |
| 40 | 3392SPF2416 | 2"X4"X16' #2 SPF LUMBER | 200 | EA 18.66 LBS | \$12.79 | \$2,558.00 |
| 50 | 339CDX3448 | 3/4"X4'X8' CDX PLYWOOD 23/32" 18MM | 80 | EA 60 LBS | \$34.56 | \$2,764.80 |

| | |
|------------------------|--------------|
| Shipped amount | \$30,083.80 |
| Order charges | \$0.00 |
| Tax amount | \$0.00 |
| Lumber Tax rate/amount | 1.00% \$0.00 |
| Quote total | \$30,083.80 |

Adjustments for #163 - 2022 Chevy Silverado 2500 Pick up Truck in All Saved Models

March 4, 2026

Chevrolet SILVERADO 2500HD 4X4 DIESEL
 Light Duty Trucks

 Size Class:
 3
 Weight:
 N/A

Configuration for SILVERADO 2500HD 4X4 DIESEL

| | | | |
|-----------------------------|--------------|-----------|--------------|
| Power Mode | Diesel | Wheelbase | 149.4 Inches |
| Gross Vehicle Weight Rating | 11200 Pounds | | |

Blue Book Rates

** FHWA Rate is equal to the monthly ownership cost divided by 176 plus the hourly estimated operating cost.

| | Ownership Costs | | | | Estimated Operating Costs Hourly | FHWA Rate** Hourly |
|---------------------------------------|-----------------------|-----------------------|---------------------|--------------------|-------------------------------------|-----------------------|
| | Monthly | Weekly | Daily | Hourly | | |
| Published Rates | USD \$3,830.00 | USD \$1,075.00 | USD \$270.00 | USD \$41.00 | USD \$19.35 | USD \$41.11 |
| Adjustments | | | | | | |
| Region (100%) | - | - | - | - | | |
| Model Year (2022: 97.06%) | (USD \$112.73) | (USD \$31.64) | (USD \$7.95) | (USD \$1.21) | | |
| Adjusted Hourly Ownership Cost (100%) | - | - | - | - | | |
| Hourly Operating Cost (100%) | | | | | - | |
| Total: | USD \$3,717.27 | USD \$1,043.36 | USD \$262.05 | USD \$39.79 | USD \$19.35 | USD \$40.47 |

Non-Active Use Rates

| | |
|--------------|---------------|
| | Hourly |
| Standby Rate | USD \$12.74 |
| Idling Rate | USD \$28.85 |

Rate Element Allocation

| Element | Percentage | Value |
|-----------------------------|------------|-------------------|
| Depreciation (ownership) | 27.57% | USD \$1,055.91/mo |
| Overhaul (ownership) | 39.7% | USD \$1,520.38/mo |
| CFC (ownership) | 16.48% | USD \$631.24/mo |
| Indirect (ownership) | 16.25% | USD \$622.46/mo |
| Fuel (operating) @ USD 3.83 | 39.95% | USD \$7.73/hr |

Revised Date: 1st quarter 2026

These are the most accurate rates for the selected Revision Date(s). However, due to more frequent online updates, these rates may not match Rental Rate Blue Book® Print. Visit the Cost Recovery Product Guide on our Help page for more information.

The equipment represented in this report has been exclusively prepared for (rdleonardo@verdeelectric.com)

Adjustments for Rack/Box Truck 156 in All Saved Models

March 4, 2026

Miscellaneous 6X6 70KGVW DSL
 On-Highway Truck Tractors

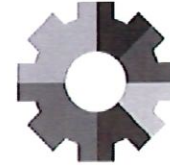
 Size Class:
60,001 lbs & Over
 Weight:
 N/A

Configuration for 6X6 70KGVW DSL

| | | | |
|------------------------------|--------------------|------------|-----------------|
| Axle Configuration | 6X6 | Horsepower | 450.0 hp |
| Maximum Gross Vehicle Weight | 70000.0 lbs | Power Mode | Diesel |

Blue Book Rates

** FHWA Rate is equal to the monthly ownership cost divided by 176 plus the hourly estimated operating cost.

| | Ownership Costs | | | | Estimated Operating Costs | FHWA Rate** |
|---------------------------------------|-----------------------|-----------------------|---------------------|--------------------|---------------------------|--------------------|
| | Monthly | Weekly | Daily | Hourly | Hourly | Hourly |
| Published Rates | USD \$4,465.00 | USD \$1,250.00 | USD \$315.00 | USD \$47.00 | USD \$61.38 | USD \$86.75 |
| Adjustments | | | | | | |
| Region (New York: 104%) | USD \$178.60 | USD \$50.00 | USD \$12.60 | USD \$1.88 | | |
| Model Year (2023: 99.94%) | (USD \$2.63) | (USD \$0.74) | (USD \$0.19) | (USD \$0.03) | | |
| Adjusted Hourly Ownership Cost (100%) | - | - | - | - | | |
| Hourly Operating Cost (100%) | | | | | - | |
| Total: | USD \$4,640.97 | USD \$1,299.26 | USD \$327.41 | USD \$48.85 | USD \$61.38 | USD \$87.75 |

Non-Active Use Rates

| | Hourly |
|--------------|-------------|
| Standby Rate | USD \$16.50 |
| Idling Rate | USD \$68.61 |

Rate Element Allocation

| Element | Percentage | Value |
|-----------------------------|------------|-------------------|
| Depreciation (ownership) | 42.27% | USD \$1,887.24/mo |
| Overhaul (ownership) | 37.42% | USD \$1,670.85/mo |
| CFC (ownership) | 9.36% | USD \$418.00/mo |
| Indirect (ownership) | 10.95% | USD \$488.91/mo |
| Fuel (operating) @ USD 3.83 | 68.82% | USD \$42.24/hr |

Revised Date: 1st quarter 2026

These are the most accurate rates for the selected Revision Date(s). However, due to more frequent online updates, these rates may not match Rental Rate Blue Book® Print. Visit the Cost Recovery Product Guide on our Help page for more information.

The equipment represented in this report has been exclusively prepared for (rdleonardo@verdeelectric.com)

Adjustments for Rack/Box Truck 156 in All Saved Models

March 4, 2026

Miscellaneous 6X6 70KGVW DSL
 On-Highway Truck Tractors

 Size Class:
60,001 lbs & Over
 Weight:
 N/A

Configuration for 6X6 70KGVW DSL

| | | | |
|------------------------------|--------------------|------------|-----------------|
| Axle Configuration | 6X6 | Horsepower | 450.0 hp |
| Maximum Gross Vehicle Weight | 70000.0 lbs | Power Mode | Diesel |

Blue Book Rates

** FHWA Rate is equal to the monthly ownership cost divided by 176 plus the hourly estimated operating cost.

| | Ownership Costs | | | | Estimated Operating Costs | FHWA Rate** |
|---------------------------------------|-----------------------|-----------------------|---------------------|--------------------|---------------------------|--------------------|
| | Monthly | Weekly | Daily | Hourly | Hourly | Hourly |
| Published Rates | USD \$4,465.00 | USD \$1,250.00 | USD \$315.00 | USD \$47.00 | USD \$61.38 | USD \$86.75 |
| Adjustments | | | | | | |
| Region (New York: 104%) | USD \$178.60 | USD \$50.00 | USD \$12.60 | USD \$1.88 | | |
| Model Year (2023: 99.94%) | (USD \$2.63) | (USD \$0.74) | (USD \$0.19) | (USD \$0.03) | | |
| Adjusted Hourly Ownership Cost (100%) | - | - | - | - | | |
| Hourly Operating Cost (100%) | | | | | - | |
| Total: | USD \$4,640.97 | USD \$1,299.26 | USD \$327.41 | USD \$48.85 | USD \$61.38 | USD \$87.75 |

Non-Active Use Rates

| | |
|--------------|---------------|
| | Hourly |
| Standby Rate | USD \$16.50 |
| Idling Rate | USD \$68.61 |

Rate Element Allocation

| Element | Percentage | Value |
|-----------------------------|------------|-------------------|
| Depreciation (ownership) | 42.27% | USD \$1,887.24/mo |
| Overhaul (ownership) | 37.42% | USD \$1,670.85/mo |
| CFC (ownership) | 9.36% | USD \$418.00/mo |
| Indirect (ownership) | 10.95% | USD \$488.91/mo |
| Fuel (operating) @ USD 3.83 | 68.82% | USD \$42.24/hr |

Revised Date: 1st quarter 2026

These are the most accurate rates for the selected Revision Date(s). However, due to more frequent online updates, these rates may not match Rental Rate Blue Book® Print. Visit the Cost Recovery Product Guide on our Help page for more information.

The equipment represented in this report has been exclusively prepared for (rdileonardo@verdeelectric.com)

Adjustments for pc-78us-10 in All Saved Models
Komatsu PC78US-10
 Crawler Mounted Hydraulic Excavators

 Size Class:
 6.5 - 8.4 mt
 Weight:
 N/A

Configuration for PC78US-10

| | | | |
|------------|----------------|------------------|--------------------|
| Horsepower | 65.5 hp | Operating Weight | 17747.0 lbs |
| Power Mode | Diesel | | |

Blue Book Rates

** FHWA Rate is equal to the monthly ownership cost divided by 176 plus the hourly estimated operating cost.

| | Ownership Costs | | | | Estimated Operating Costs Hourly USD \$17.63 | FHWA Rate** Hourly USD \$55.16 |
|---------------------------------------|-----------------------|-----------------------|---------------------|--------------------|--|--------------------------------------|
| | Monthly | Weekly | Daily | Hourly | | |
| Published Rates | USD \$6,605.00 | USD \$1,850.00 | USD \$465.00 | USD \$70.00 | | |
| Adjustments | | | | | | |
| Region (100%) | - | - | - | - | | |
| Model Year (2022: 99.94%) | (USD \$4.19) | (USD \$1.17) | (USD \$0.30) | (USD \$0.04) | | |
| Adjusted Hourly Ownership Cost (100%) | - | - | - | - | | |
| Hourly Operating Cost (100%) | | | | | - | |
| Total: | USD \$6,600.81 | USD \$1,848.83 | USD \$464.70 | USD \$69.96 | USD \$17.63 | USD \$55.13 |

Non-Active Use Rates

| | Hourly |
|--------------|-------------|
| Standby Rate | USD \$20.95 |
| Idling Rate | USD \$42.27 |

Rate Element Allocation

| Element | Percentage | Value |
|-----------------------------|------------|-------------------|
| Depreciation (ownership) | 31.78% | USD \$2,098.95/mo |
| Overhaul (ownership) | 44.15% | USD \$2,916.09/mo |
| CFC (ownership) | 15.44% | USD \$1,019.92/mo |
| Indirect (ownership) | 8.63% | USD \$570.03/mo |
| Fuel (operating) @ USD 3.83 | 27.06% | USD \$4.77/hr |

Revised Date: 1st quarter 2026

These are the most accurate rates for the selected Revision Date(s). However, due to more frequent online updates, these rates may not match Rental Rate Blue Book® Print. Visit the Cost Recovery Product Guide on our Help page for more information.

The equipment represented in this report has been exclusively prepared for (rdileonardo@verdeelectric.com)



Insurance | Risk Management | Consulting

30 Century Hill Drive, Suite 200
Latham, NY 12110
USA

518-869-3535
www.ajg.com

January 26, 2026

Verde Electric Maintenance Corporation.
89 Edison Avenue
Mount Vernon, NY 10550

**Re: Workers Compensation Experience Modifications
Verde Electric Maintenance Corporation.**

Dear Tricia:

Please allow this letter to acknowledge and confirm the Workers Compensation Experience Modification for the above.

The EMR's are as follows:

| <u>Effective Year</u> | <u>Experience Modification</u> |
|-----------------------|--------------------------------|
| 10/30/25 to 10/30/26 | 1.00 |

We trust you will find the enclosed in order but should you have any questions please contact our office.

Sincerely,

Julie Kaiser
Client Service Manager



Insurance | Risk Management | Consulting

March 4, 2026

New York State Department of Transportation
50 Wolf Road
Albany, NY 12232

Re: Insured - Verde Electric Corp - 89 Edison Avenue, Mount Vernon, NY 10550

General Liability/ Umbrella Insurance Rate Calculation Based on Sales:

| | | |
|---|----------------------------|-----------------------|
| General Liability (per \$100 of payroll) | \$30.65 | See below for support |
| Lead Umbrella (per \$100 of payroll) | \$5.50 | See below for support |
| First Umbrella (per \$100 of payroll) | \$4.00 | See below for support |
| Second Umbrella (per \$100 of payroll) | \$3.50 | See below for support |
| Total | \$43.65 \$40.15 | |
| Per \$100 of payroll | | |
| Verde Electric GL & Umbrella Rate | 43.65% 40.15% | |

General Liability

Insuring Company: Traveler Indemnity Company.

AM. Best Rating: A++XV (Admitted)

Policy Number: VTC2KCO3X459385IND25

Policy Expires: 10/31/2026

Limit of Liability:

General Aggregate: \$4,000,000

Products Completed Operations Aggregate: \$4,000,000

Personal & Advt. Injury: \$2,000 ,000

Each Occurrence: \$ 2,000,000

Damage to Rented Premise: \$300,000

Rate- \$30.65 per \$100 of Payroll



Insurance | Risk Management | Consulting

Excess Umbrella Liability

Insuring Company: Starr Indemnity & Liability Company Company.

AM. Best Rating: A++XV (Admitted)

Policy Number: 1100588039251

Policy Expires: 10/31/2026

Limit of Liability:

General Aggregate: \$3,000,000

Each Occurrence: \$3,000,000

Rate- \$5.50 per \$100 of Payroll

Excess Umbrella Second

Insuring Company: Berkley Casualty Company

AM. Best Rating: A+XV (Admitted)

Policy Number: BCS880013440

Policy Expires: 10/31/2026

Limit of Liability:

General Aggregate: \$7,000,000

Each Occurrence: \$7,000,000

Rate- \$4.00 per \$100 of Payroll

Excess Umbrella Third

Insuring Company: Zurich Insurance Company & Liberty Insurance Underwriting

AM. Best Rating: A+XV (Admitted) and A XV (Admitted)

Policy Number: AEC7130570-03 and 100057021602

Policy Expires: 10/31/2026

Limit of Liability:

General Aggregate: \$10,000,000



Insurance | Risk Management | Consulting

Each Occurrence: \$10,000,000

Rate- \$3.50 per \$100 of Payroll

Workers Compensation

Insuring Company: Charter Oak Fire Ins. Co. (Travelers)

AM. Best Rating: A++XV

Policy Number: UB4X4902572525H

Policy Expires: 10/31/2026

Limit of Liability:

Each Accident: Statutory Disease

Policy Limit: Statutory

Disease: Each Employee: Statutory

Exposure: Electrical Wiring Rate: \$12.38 per \$100 of Payroll: Conduit Rate - \$16.74 per \$100

Average Rate: \$14.56 per \$100 of Payroll (See Support Below)

| | Estimated Payroll | Rate per \$100 | Premium |
|-------------------|-----------------------|----------------|---------------------|
| Electrical Wiring | \$1,100,000.00 | 12.38% | \$136,111.80 |
| Conduit | \$1,300,909.00 | 16.74% | \$217,623.90 |
| Total: | \$2,400,000.00 | | \$353,735.70 |
| | | 14.56% | Blended Rate |

If you would like to speak with me directly please feel free to contact me. My email address is David_Brockmann@ajg.com; my office phone number is 518-533-6898 and my mobile phone number is 518- 330-1743.

David Brockmann

David Brockmann, Jr.
Area Vice President
Director of Construction Services
Arthur J. Gallagher Risk Management Services

Reset Form

NEW YORK STATE DEPARTMENT OF TRANSPORTATION COST ANALYSIS WORKSHEET (9/22)

Print Form

Contract D# **036472**

Change Order # **001**

Field Change Payment #

CO Item Qty **2**

Section 1 - Existing Contract Item

Use the Item Analysis Report and CONR 22 Composite Report in BI to fill out the below information. Follow Added Work Cost Analysis Decision Flow Chart.

Item Spec No

Unit Bid Price

Bid Qty

Current Contract Qty

Major Item

Minor Item

75% Threshold

Renegotiation Threshold
(200% and \$5,000 over

125% Threshold

original contract amount)

High Bid Item (over 125%) Yes No

Section 2 - New Contract Item or Continuation of Existing Item

New Item Spec No **950.0402A**

Renegotiated Qty **2**

Contractor Quoted Unit Price **\$10,633.72**

Method Chosen:

- Original Bid Price Acceptable?
- Contractor agrees to work at the Original Contract Bid Price adjusted for documented changes in material costs, equipment rates, mobilization, and/or site conditions, and bid price is reasonable compensation for the quantity of added work: include letter from contractor, and supporting documentation for adjustments (need price analysis) on CO Header
- Weighted Average Price (WAP) Comparison (must have at least 3 contracts)

Pay Item Catalog Date Range to

PIC Qty Range to N/A

Regional WAP Statewide WAP

Printout of PIC w/ Qty Range, dates, prices attached?

- Comparison to Average of 3 Lowest Bidders (on contract, not item)

Average Price **\$0.00** Bidder 1

Bidder 2

Bidder 3

Printout of 3 Lowest Bidders on the Contract attached?

- Price Analysis

MURK 26/27 Price Analysis Worksheet attached and all documentation attached?

- Force Account Work (FAW)

FE (Force Estimate) Estimate of Labor, Materials, and Equipment work up included?

FAW (Final) Included with all MURK forms and documentation attached?

Project Conditions/Variance Explanation attached?

Signature 

Date **Mar 25, 2026**

MURK 26
(11/22)

NEW YORK STATE DEPARTMENT OF TRANSPORTATION

Agreed Price Worksheet - Prime Contractor

Contract: 8758.75 Item No.: 950.0403 Quantity: 2.00 Units: EA

Item Description : Colored Concrete for Type 11 Curb Ramps w/ Pro350 Sealer & Slip Resistant

(A) LABOR

| Trade | Reg Hours | Wage Rate | Cost | Fringe Hours | Fringe Rate | Cost |
|-------------------------------|-----------|-----------|-------------|--------------|-------------|-------------|
| 137 Operator Foreman | 14.00 | \$ 65.26 | \$ 913.64 | 14.00 | \$ 50.46 | \$ 706.44 |
| 60 Laborer Group 2 | 42.00 | \$ 50.71 | \$ 2,129.82 | 42.00 | \$ 34.82 | \$ 1,462.44 |
| 60 ACI Concrete Finisher Grp1 | 14.00 | \$ 56.27 | \$ 787.78 | 14.00 | \$ 35.14 | \$ 491.96 |
| 137 Operator Journeyman | 4.00 | \$ 62.07 | \$ 248.28 | 4.00 | \$ 50.14 | \$ 200.56 |
| | | | | | | |
| | | | | | | |
| | | | | | | |
| | | | | | | |

Wages \$ 4,079.52 Fringes \$ 2,861.40

If Fringes are paid directly to employee via cash or check, Enter value here:

\$ 0.00
14.56 %

Worker's Compensation Rate (%):

Total of Wages and Fringes: \$ 6,940.92

Workers Compensation: \$ 593.98

Standard Labor Markup: \$ 509.94

Fringe Benefit Markup: \$ 0.00

Labor Total: \$ 8,044.84

(The Contractor shall submit an insurance policy declaration / rate page from its insurer to validate the Workers Comp insurance rate based on an EMR of 1.0.)

(B) MATERIALS

| Description | Units | # of Units | Cost/Unit | Cost | Description | Units | # of Units | Cost/Unit | Cost |
|---------------------|-------|------------|-----------|----------|------------------|-------|------------|------------|------------|
| Colored Concrete | CY | 2.00 | \$301.59 | \$603.18 | HC Tiles | EA | 4.00 | \$133.32 | \$533.28 |
| Pro350 Sealer | PAIL | 0.50 | \$289.17 | \$144.59 | Granite Curb | LS | 1.00 | \$1,988.25 | \$1,988.25 |
| Slip-Resist Additiv | BOX | 0.50 | \$21.47 | \$10.73 | Class A Concrete | CY | 1.00 | \$171.00 | \$171.00 |
| Paint Supplies | LS | 0.50 | \$170.00 | \$85.00 | Asphalt | TON | 1.00 | \$91.00 | \$91.00 |

Materials Total: \$3,627.03

(C) EQUIPMENT

| Description | Hours | FHWA Rate | Cost | Description | Hours | FHWA Rate | Cost |
|---------------|-------|-----------|------------|-------------|-------|-----------|------|
| Pickup Truck | 14.00 | \$41.11 | \$575.54 | | | | |
| Box Truck | 14.00 | \$86.75 | \$1,214.50 | | | | |
| Rack Truck | 14.00 | \$86.75 | \$1,214.50 | | | | |
| Komatsu PC-78 | 4.00 | \$55.16 | \$220.64 | | | | |

Equipment Total: \$ 3,225.18

(D) SERVICES

| Description / Type | # of Units | Cost / Unit | Cost | Description / Type | # of Units | Cost / Unit | Cost |
|--------------------|------------|-------------|------|--------------------|------------|-------------|------|
| | | | | | | | |
| | | | | | | | |

Services Total:

(E) OVERHEAD & PROFIT

| | OH & Profit % | Cost |
|--------------------------------------|---------------|-------------|
| Labor, Materials, & Equipment Total: | 20.00 | \$ 2,979.41 |
| Services: | | \$ 0.00 |

Overhead & Profit Total: \$ 2,979.41

(F) INSURANCE

Enter rate here if based on payroll

Payroll Based Cost Basis

Enter rate here if based on sales

Sales Based Cost Basis

40.15 %

\$ 4,079.52

\$ 0.00

Insurance Total: \$ 1,637.93

Item Total: \$ 19,514.39

Unit Price: \$ 9,757.19 per EA

Robert Craig
Contractor's Rep Name

Robert Craig
Signature

3-12-26
Date

Arlisa McGrath
Engineer-in-Charge's Name

Arlisa McGrath
Signature

4/9/26
Date

VERDE ELECTRIC CORP LABOR RATE BREAKDOWN

EFFECTIVE DATES:

FROM: 3/4/2025
 TO: 3/3/2026

TRADE CLASSIFICATION: OPERATORS OS FOREMAN

UNION: OPERATING ENGINEERS
 LOCAL NO: 137

| | | Straight Time | Overtime & Saturday | Sunday |
|---|-----------------------------------|---------------|---------------------|-----------|
| 1 HOURLY RATE | | \$ 65.26 | \$ 97.89 | \$ 130.52 |
| 2 FRINGES: | | RATE | | |
| | Welfare | \$21.40 | \$21.40 | \$ 21.40 |
| | Vacation | \$3.20 | \$ 3.20 | \$ 3.20 |
| | Savings/PSL | \$1.10 | \$ 1.10 | \$ 1.10 |
| | Pension | \$5.18 | \$ 5.18 | \$ 5.18 |
| | Apprenticeship | \$1.30 | \$ 1.30 | \$ 1.30 |
| | National Training | \$0.10 | \$ 0.10 | \$ 0.10 |
| | Annuity | \$8.50 | \$ 8.50 | \$ 8.50 |
| | IAF | \$0.50 | \$ 0.50 | \$ 0.50 |
| | Supplemental Dues | 3.75% | \$ 2.45 | \$ 3.67 |
| | PAC | \$0.05 | \$ 0.05 | \$ 0.05 |
| | LMCT | \$1.00 | \$ 1.00 | \$ 1.00 |
| ** | Holiday | \$5.68 | \$ 5.68 | \$ 5.68 |
| TOTAL FRINGES: | | \$ 50.46 | \$ 51.68 | \$ 52.90 |
| 3 PAYROLL TAXES & INSURANCE | | RATE | | |
| | FICA (Social Security & Medicare) | 7.65% | \$ 4.99 | \$ 7.49 |
| | Federal Unemployment | 0.60% | \$ 0.39 | \$ 0.59 |
| | Metro Tax | 0.34% | \$ 0.22 | \$ 0.33 |
| | New York Unemployment | 8.33% | \$ 5.44 | \$ 8.15 |
| | Workers Comp | 7.80% | \$ 5.09 | \$ 5.09 |
| | General Liability | 15.50% | \$ 10.12 | \$ 15.17 |
| TOTAL PAYROLL TAXES & INSURANCE: | | | \$ 26.25 | \$ 36.83 |
| 4 TOTAL LABOR RATE, FRINGES, TAXES & INSURANCE | | | \$ 141.96 | \$ 186.40 |
| | | | \$ 230.83 | |

** Holiday computed as 80 hour cost divided by 1,920 (est. 48 week work year)

VERDE ELECTRIC CORP LABOR RATE BREAKDOWN

EFFECTIVE DATES:

FROM: 3/30/2025
TO: 3/28/2026

TRADE CLASSIFICATION: GROUP II

UNION: HVY, HWY, UTILITY
LOCAL NO: 60

| | | Straight Time | Overtime & Saturday | Sunday |
|--|-------------|---------------|---------------------|-----------|
| 1 HOURLY RATE | | | | |
| | | \$ 50.71 | \$ 76.07 | \$ 101.42 |
| 2 FRINGES: | | | | |
| | RATE | | | |
| Welfare | \$10.63 | \$ 10.63 | \$ 10.63 | \$ 10.63 |
| Pension | \$11.15 | \$ 11.15 | \$ 11.15 | \$ 11.15 |
| Annuity | \$6.00 | \$ 6.00 | \$ 6.00 | \$ 6.00 |
| Apprentice & Training | \$1.10 | \$ 1.10 | \$ 1.10 | \$ 1.10 |
| Labor Management | \$0.95 | \$ 0.95 | \$ 0.95 | \$ 0.95 |
| LECET | \$0.15 | \$ 0.15 | \$ 0.15 | \$ 0.15 |
| NY Health and Safety | \$0.10 | \$ 0.10 | \$ 0.10 | \$ 0.10 |
| IAF | \$0.50 | \$ 0.50 | \$ 0.50 | \$ 0.50 |
| ** Holiday | \$4.24 | \$ 4.24 | \$ 4.24 | \$ 4.24 |
| TOTAL FRINGES: | | \$ 34.82 | \$ 34.82 | \$ 34.82 |
| 3 PAYROLL TAXES & INSURANCE | | | | |
| | RATE | | | |
| FICA (Social Security & Medicare) | 7.65% | \$ 3.88 | \$ 5.82 | \$ 7.76 |
| Federal Unemployment | 0.60% | \$ 0.30 | \$ 0.46 | \$ 0.61 |
| Metro Tax | 0.34% | \$ 0.17 | \$ 0.26 | \$ 0.34 |
| New York Unemployment | 8.33% | \$ 4.22 | \$ 6.33 | \$ 8.44 |
| Workers Comp | 7.80% | \$ 3.96 | \$ 3.96 | \$ 3.96 |
| General Liability | 15.50% | \$ 7.86 | \$ 11.79 | \$ 15.72 |
| TOTAL PAYROLL TAXES & INSURANCE: | | \$ 20.39 | \$ 28.61 | \$ 36.83 |
| 4 TOTAL LABOR RATE, TAXES & INSURANCE | | | | |
| | | \$ 105.92 | \$ 139.49 | \$ 173.07 |

** Holiday computed as 80 hour cost divided by 1,920 (est. 48 week work year)

VERDE ELECTRIC CORP LABOR RATE BREAKDOWN

EFFECTIVE DATES:

FROM: 3/30/2025
 TO: 3/28/2026

TRADE CLASSIFICATION: GROUP I

UNION: HVY, HWY, UTILITY
 LOCAL NO: 60

| | | Straight Time | Overtime & Saturday | Sunday |
|--|-------------|------------------|---------------------|------------------|
| 1 HOURLY RATE | | | | |
| | | \$ 56.27 | \$ 84.41 | \$ 112.54 |
| 2 FRINGES: | | | | |
| | RATE | | | |
| Welfare | \$10.63 | \$ 10.63 | \$ 10.63 | \$ 10.63 |
| Pension | \$11.15 | \$ 11.15 | \$ 11.15 | \$ 11.15 |
| Annuity | \$6.00 | \$ 6.00 | \$ 6.00 | \$ 6.00 |
| Apprentice & Training | \$1.10 | \$ 1.10 | \$ 1.10 | \$ 1.10 |
| Labor Management | \$0.95 | \$ 0.95 | \$ 0.95 | \$ 0.95 |
| LECET | \$0.15 | \$ 0.15 | \$ 0.15 | \$ 0.15 |
| NY Health and Safety | \$0.10 | \$ 0.10 | \$ 0.10 | \$ 0.10 |
| IAF | \$0.50 | \$ 0.50 | \$ 0.50 | \$ 0.50 |
| ** Holiday | \$4.56 | \$4.56 | \$ 4.56 | \$ 4.56 |
| TOTAL FRINGES: | | \$ 35.14 | \$ 35.14 | \$ 35.14 |
| 3 PAYROLL TAXES & INSURANCE | | | | |
| | RATE | | | |
| FICA (Social Security & Medicare) | 7.65% | \$ 4.30 | \$ 6.46 | \$ 8.61 |
| Federal Unemployment | 0.60% | \$ 0.34 | \$ 0.51 | \$ 0.68 |
| Metro Tax | 0.34% | \$ 0.19 | \$ 0.29 | \$ 0.38 |
| New York Unemployment | 8.33% | \$ 4.68 | \$ 7.03 | \$ 9.37 |
| Workers Comp | 7.80% | \$ 4.39 | \$ 4.39 | \$ 4.39 |
| General Liability | 15.50% | \$ 8.72 | \$ 13.08 | \$ 17.44 |
| TOTAL PAYROLL TAXES & INSURANCE: | | \$ 22.63 | \$ 31.75 | \$ 40.87 |
| 4 TOTAL LABOR RATE, TAXES & INSURANCE | | | | |
| | | \$ 114.04 | \$ 151.30 | \$ 188.55 |

** Holiday computed as 80 hour cost divided by 1,920 (est. 48 week work year)

VERDE ELECTRIC CORP LABOR RATE BREAKDOWN

EFFECTIVE DATES:

FROM: 3/4/2025
 TO: 3/3/2026

TRADE CLASSIFICATION:

OPERATOR JOURNEYMAN

UNION:

OPERATING ENGINEERS

LOCAL NO:

137

| | | Straight Time | Overtime & Saturday | Sunday |
|---|-----------------------------------|------------------|------------------------|------------------|
| 1 HOURLY RATE | | \$ 62.07 | \$ 93.11 | \$ 124.14 |
| 2 FRINGES: | | RATE | | |
| | Welfare | \$21.40 | \$ 21.40 | \$ 21.40 |
| | Vacation | \$3.20 | \$ 3.20 | \$ 3.20 |
| | Savings/PSL | \$1.10 | \$ 1.10 | \$ 1.10 |
| | Pension | \$5.18 | \$ 5.18 | \$ 5.18 |
| | Apprenticeship | \$1.30 | \$ 1.30 | \$ 1.30 |
| | National Training | \$0.10 | \$ 0.10 | \$ 0.10 |
| | Annuity | \$8.50 | \$ 8.50 | \$ 8.50 |
| | IAF | \$0.50 | \$ 0.50 | \$ 0.50 |
| | Supplemental Dues | 3.75% | \$ 2.33 | \$ 3.49 |
| | PAC | \$0.05 | \$ 0.05 | \$ 0.05 |
| | LMCT | \$1.00 | \$ 1.00 | \$ 1.00 |
| ** | Holiday | \$5.49 | \$ 5.49 | \$ 5.49 |
| TOTAL FRINGES: | | \$ 50.14 | \$ 51.31 | \$ 52.47 |
| 3 PAYROLL TAXES & INSURANCE | | RATE | | |
| | FICA (Social Security & Medicare) | 7.65% | \$ 4.75 | \$ 7.12 |
| | Federal Unemployment | 0.60% | \$ 0.37 | \$ 0.56 |
| | Metro Tax | 0.34% | \$ 0.21 | \$ 0.32 |
| | New York Unemployment | 8.33% | \$ 5.17 | \$ 7.76 |
| | Workers Comp | 7.80% | \$ 4.84 | \$ 4.84 |
| | General Liability | 15.50% | \$ 9.62 | \$ 14.43 |
| TOTAL PAYROLL TAXES & INSURANCE: | | \$ 24.96 | \$ 35.03 | \$ 45.09 |
| 4 TOTAL LABOR RATE, FRINGES, TAXES & INSURANCE | | \$ 137.18 | \$ 179.44 | \$ 221.70 |

** Holiday computed as 80 hour cost divided by 1,920 (est. 48 week work year)



OFFER

Cranesville Block Co., Inc.
 1250 Riverfront Center
 Amsterdam, NY 12010
 www.cranesville.com

Phone: 518-684-6000
 Dispatch: 518-684-6085
 Sales: 518-684-6078
 Sales Fax: 518-684-0128
 Credit: 518-684-6004

Ready Mixed Concrete - Aggregates - Masonry Units - Precast - Masonry Supplies

Customer Name Verde Electric
 Attention Anthony Mauriello
 Office Phone (914) 664-7000
 Cell Phone (914) 652-3908
 Email amauriello@verdeelectric.com
 Fax (914) 668-7997
 Yards 800
 Quote Number 00011972

Project Name Broadway Improvements Newburgh
 Project Address Robinson Ave
 Project Newburgh, NY
 Address(Cont'd)
 Quote Date 8/8/2025
 Expiration Date 12/31/2025
 Project Salesman Bill Cobey
 Salesman Mobile 845-313-0626
 Salesman Email wcobey@cranesville.com
 Sales Assoc. Patti Bieniek
 Sales Assoc. Phone 518-684-6119
 Sales Assoc. Email pbieniek@cranesville.com

| Quantity | Product | Line Item Description | Sales Price | UM |
|----------|------------------|--|-------------|----|
| 800.00 | Class D Concrete | Straight Cement for colored concrete (Included 1.5 lbs. fiber for sidewalks) | \$196.45 | CY |

***Due to the potential disruption in the cement supply chain, we reserve the right to requote as necessary.**

Above mixes are designed to have a 2"- 4" slump.
 If a 4"- 6" slump is required a Midrange will need to be used at additional price listed below
 If a 7"-9" slump is required a Super Plasticizer will need to be used at additional price listed below
 Plants are NYSDOT approved; not NRMCA.

Additional Information: **SIKA COLOR #14 GRAY (4 BAGS/YARD) \$109.50/CY**

Please see the Terms & Conditions on the last page of this Offer.
MINIMUM OF A 6% INCREASE ON ALL BELOW PRODUCTS FOR EACH SUBSEQUENT YEAR.

Class D base price w/ fiber \$196.45 / CY

Sample load CID 11 CY @ \$196.45
 sika color 11 CY @ \$109.50
 Environmental Charge 1 ea @ \$13.99
 Color washout 1 ea @ \$50.00
 fuel surcharge 1 ea @ \$25.00

Total: \$3,454.44

deduct Fiber -\$12.45 = ~~\$314.04 / CY~~
 = \$301.59



OFFER

Cranesville Block Co., Inc.
 1250 Riverfront Center
 Amsterdam, NY 12010
 www.cranesville.com

Phone: 518-684-6000
 Dispatch: 518-684-6085
 Sales: 518-684-6078
 Sales Fax: 518-684-0128
 Credit: 518-684-6004

Ready Mixed Concrete – Aggregates – Masonry Units – Precast – Masonry Supplies

| Additional Products and Services – Mont / Fish / Lib | | | | | |
|---|---------------|--|-------------|-------------------------------|-------------|
| Environmental Surcharge (mandatory) | \$13.99 /load | Small Stone | \$2.75 /cy | Non-Chloride 1% | \$7.15 /cy |
| Fuel Surcharge (mandatory) (subject to change) | \$25.00/load | Fiber (1 lb per cy) | \$9.25 /cy | Non-Chloride 2% | \$11.65 /cy |
| Color Washout | \$50.00 /load | Fiber (1.5 lb per cy) | \$12.45 /cy | Calcium 1% | \$5.55 /cy |
| Saturday Delivery | \$75.00 /load | Mid-Range Water Reducer | \$5.00 /cy | Calcium 2% | \$10.30 /cy |
| Truck Time (Overtime) Charge (per minute) | \$2.00 /min | High Range Water Reducer (Super Plasticizer) | \$9.25 /cy | Retarder | \$5.55 /cy |
| Cold Weather (Exact weather subject to ACI standards) | \$12.50/cy | Corrosion Inhibitor | Inquire | Moisture Vapor Reducing Admix | Inquire |
| Ice (hot weather Concrete) | Inquire | | | | |

| Terms and Conditions | |
|---|--|
| Any purchase order sent by Buyer and not signed by an authorized representative of Seller will be invalid, regardless of commencement of delivery. | |
| <ul style="list-style-type: none"> * This offer is expressly limited to and expressly made conditional on buyer's acceptance of these terms and conditions and (a copy of the Consolidated Joint Application for Extension of Credit available at http://ec.cranesville.com/pdf_files/creditapp.pdf). Seller objects to any different terms and conditions contained in any purchase order or any other document sent by buyer. Seller will not accept terms of any purchase order, which incorporate by reference terms and conditions of a separate and distinct agreement. * All invoices are due net thirty (30) days from delivery or sale; invoices remaining delinquent beyond thirty (30) days shall bear an 18% per annum finance charge. * Seller's delivery of goods to buyer constitutes buyer's acceptance of this offer in the absence of buyer's written signature. * Seller's warranty limited to full refund of purchase price. * This offer is not contingent upon strikes, riots, authority of law, acts of God and/or other causes beyond our control. Access to the project and individual delivery locations must be such that normal drive ready mixed, boom, tanker, hi-axle or tractor trailer trucks can maneuver under their own power at all times. The Seller reserves the right to stop deliveries if roadways or approaches are unsatisfactory to him/her. The buyer assumes all liability for damage to sidewalks, driveways or other property beyond the curb line and agrees to indemnify the Seller against all liability loss and expenses incurred as a result of such delivering including damage to Seller's equipment and loss of time. * The products have been designed to attain the indicated compressive strengths in accordance with recognized testing methods and standards. Field results may differ substantially due to variables such as waiting time, placing methods, weather, handling after placement, addition of substitute materials by buyer or request of buyer, such as water, and other variables beyond the control of the Seller. The Seller hereby disclaims any liability and/or warranty, expressed or implied should the buyer not use proper leveling, placing and curing methods (ACI-ASTM). Upon delivery, it is the buyer's responsibility to confirm the correct product or mix has been delivered. There will be no credit or adjustment to billing for incorrect material incorporated into the work. | <ul style="list-style-type: none"> * Sales tax will be applied to Seller Invoices unless appropriate documentation is received before ordering product. * Prices are based on full truckloads (7+CY). A short load will be charged on orders less than 7 yds (Contact sales for a copy of the rates). A balance on a plus order is one load of ten yards or less. * Heating or cooling of concrete is not included in product price. * If color is used on any job, an environmentally approved location must be available for a truck to rinse. * Hours of operation Monday - Friday 7:00 AM- 4:30 PM. Saturday 8 AM - 12 PM. Contact sales for deliveries outside of these hours. * All products that are ordered and are not listed on this quote will be billed at the standard price. * Delivery times and truck spacing are targets Seller strives for but does not guarantee due to the demands of the industry. * Truck time will be charged after the allotted 4 minutes per yard, per truck, at the rate set forth in the "Additional Products and Services" schedule. Truck time is calculated, by truck, "At Job" until "Stop Four." * All offered prices are subject to price increase(s) due to cement and/or fuel cost increases. * The above pricing is based on the project's total yardage and specified mixes. Seller and other material producing companies reserve the right to re-price based on changes in quantity and/or mix, or extraneous factors. All quoted products are standard mix designs unless specifications have been provided prior to quotation. * Waiver of Consequential Damages: Purchaser, for good and valuable consideration, and as a condition of purchase, waives against Seller any and all damages arising directly, or as a consequence of, Seller providing defective or non-conforming goods. Such waiver shall include damages arising as a direct or indirect result of costs or property damage, to adjoining work caused or created by non-conforming or defective product provided by Seller. * The "Expiration Date" includes all terms and pricing listed. Standard pricing will apply thereafter. |

Price not enforceable by Buyer if not signed within 15 days of receipt. Please sign offer and return before ordering.

ACCEPTED BY:

DATE:

This is the last page of this Offer.



ACCOUNT MANAGER: HEATHER SCHEER
 HEATHER.SCHEER@WHITECAP.COM
 860-573-8566

CUSTOMER: VERDE ELECTRIC
 NAME: ANTHONY MAURIELLO
 JOB: BROADWAY NEWBURGH PTS

2025-08-06 Whitecap 18x36" Bluestone

| Description | Packaging | Item | Each Unit (ea) | QTY | Total |
|--------------------------------------|----------------|--------|----------------|-----|--------------|
| 18"X36" Bluestone- Rigid Black | 18" x 36" | 599712 | \$ 270.97 | 6 | \$ 1,625.82 |
| 18"X36" Bluestone- Rigid Blue | 18" x 36" | 599714 | \$ 270.97 | 6 | \$ 1,625.82 |
| 18"X36" Bluestone- Rigid Green | 18" x 36" | 599716 | \$ 270.97 | 6 | \$ 1,625.82 |
| 18"X36" Bluestone- Flex Black | 18" x 36" | 599711 | \$ 270.97 | 2 | \$ 541.94 |
| 18"X36" Bluestone Flex Blue | 18" x 36" | 599713 | \$ 270.97 | 2 | \$ 541.94 |
| Bluestone Texture Touch-up Skin | 18" x 18" | 599625 | \$ 104.89 | 2 | \$ 209.78 |
| Bluestone 9" Texture Roller Sleeve | 9" x 3.25" | 600017 | \$ 88.80 | 2 | \$ 177.60 |
| 2" Chisel | 2" x 7.5" | 618415 | \$ 18.34 | 2 | \$ 36.69 |
| 4" Chisel | 4" x 8" | 618416 | \$ 29.94 | 2 | \$ 59.89 |
| 8" Chisel | 8" x 8" | 618417 | \$ 32.99 | 2 | \$ 65.98 |
| 3/16" Touch-Up Wheel | 13.5" x 2.5" | 600666 | \$ 64.21 | 2 | \$ 128.42 |
| Perma-Cast® Clear Liquid Release | 5 Gal. | 619060 | \$ 138.14 | 72 | \$ 9,946.08 |
| SikaCem®-100 PRO 350® | 5 Gal. | 761327 | \$ 289.17 | 37 | \$ 10,699.29 |
| Clear Guard® Slip-Resistant Additive | Box of 6-1 lb. | 618584 | \$ 21.57 | 37 | \$ 798.05 |

Two Sets

Notes:
 Stamp Pattern # S4210
 Recommended Contractor Stamp Set: 9 Rigid, 2 Flex, 1 Skin, 1 Roller Sleeve
 Suggested Touch-Up / Detail Tools- Chisels: 2", 4", 8", & 12" Touch-up Wheel: 3/16"
 Liquid Release Assumes 750 sf./ pail
 Lithochrome Wax assumes 200 Sf/Gal
 Pro 350 assumes 300-400 sq. ft./gal.

Approximate freight \$300.00/pallet
 Does not include Taxes
 Based on approximate 51,000 SF



Mount Ple... 10PM

10532

What can we help you find today?



Wooster

9 in. x 1/2 in. Pro Surpass Shed-Resistant Knit High-Density Fabric Roller Cover Applicator/Tool (3-Pack)

★★★★ (1887) Questions & Answers (20)



BULK PRICE
\$12.48
per unit

Buy 4 or more \$10.61

Buy 4 or More, Get 15% Off

0 of 4 items

Add 4 more to qualify

[Shop This Offer](#)

- Fast results
- Shed-resistant knit
- Even coverage
- [View More Details](#)

Mount Pleasant Store

✓ 46 in stock Aisle 36, Bay 006

Package Quantity: 3

1

Nap Size/Thickness (in.): 1/2

Product Width (in.): 9 in

RESEALABLE BAG



15% Off



Mount Ple... 10PM 10532 What can we help you find today?



Internet # 100187725 Model # 00R0550000 Store SKU # 1000022322

... / Paint / Paint Supplies / Paint Roller Extension Poles / Wooster Paint Roller Extension Poles

Top Rated

Wooster

Sherlock 4 ft. - 8 ft. Adjustable Extension Pole

★★★★★ (2040) Questions & Answers (47)



\$27.48

Pay \$2.48 after \$25 OFF your total qualifying purchase upon opening a new card.



Apply for a Home Depot Consumer Card

Buy 4 or More, Get 15% Off

0 of 4 items

15% Off

Add 4 more to qualify

[Shop This Offer](#)

- Thumb lever locks in 6 in. increments to adjust pole length
- Threaded tip fits most roller frames and tools
- Sturdy and durable
- [View More Details](#)

Mount Pleasant Store

✓ 35 in stock Aisle 36, Bay SC1

Minimum length (ft.): 4

| | | | |
|---|---|---|---|
| 2 | 4 | 6 | 8 |
|---|---|---|---|

Maximum length (ft.): 8





Mount Ple... 10PM 10532

What can we help you find today?



Best Seller

9 in. Heavy Duty 5-Wire Paint Roller Frame

★★★★★ (1145) Questions & Answers (7)

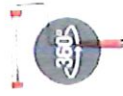

\$4.48



- For use with all standard 9" paint roller covers
- 5-wire cage durably crafted with sturdy steel
- Threaded handle end is compatible with most extension poles
- [View More Details](#)

Mount Pleasant Store

✓ 300 in stock Aisle 36, Bay 008

Pickup at

Mount Pleasant

Delivering to 10532

Pickup Today
300 in stock
FREE

Delivery Tomorrow
304 available
FREE

[Check Nearby Stores](#)

[Delivery Details](#)

Order within **5 hrs 57 mins** to get it by **Tomorrow**

Get it delivered Today for \$2.99. Schedule your delivery in checkout.

One-Time Purchase

Hover Image to Zoom

9 in. Metal Paint Roller Tray

★★★★★ (991) Questions & Answers (3)

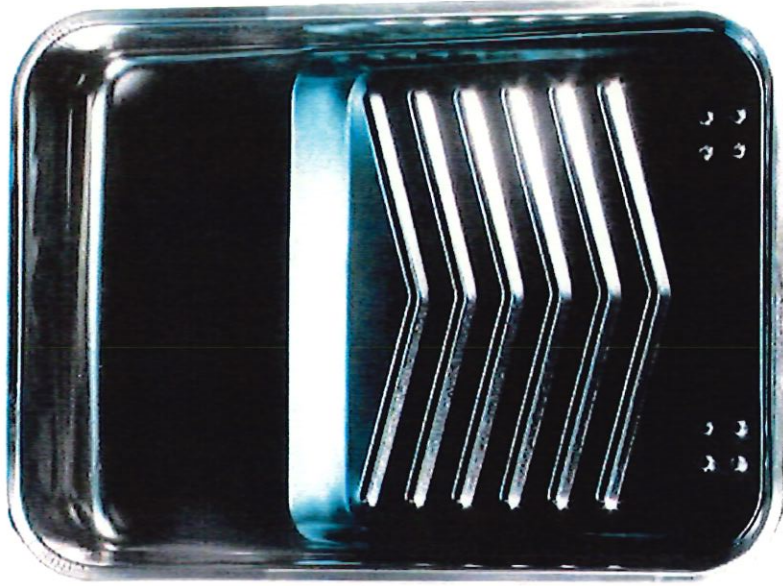

Hover Image to Zoom

\$3.98



- Designed for use with standard 9 in. roller covers and frames
- Made with solvent-resistant metal for durability
- Holds up to 1 quart paint or stain
- [View More Details](#)

Mount Pleasant Store

✓ 111 in stock Aisle 36, Bay 008

Pickup at

[Mount Pleasant](#)

Delivering to [10532](#)

Pickup
Today
111 in stock
FREE

Delivery
Tomorrow
428 available
FREE

[Check Nearby Stores](#)

[Delivery Details](#)



Get it delivered Today for \$2.99. Schedule your delivery in checkout.

1 +

[Add to Cart](#)

PayPal

Pay in 4 interest-free payments on purchases of \$30-\$1,500 with **PayPal**. [Learn more](#)

[Share](#) [Print](#)

WHITE CAP ON ACCOUNT



511 - Newington CT (AHH) (PZ10)
 91 Holmes Rd
 Newington, CT, 06111
 (860) 665-9400

QUOTE

68680989

THIS IS A QUOTE ONLY DO NOT SHIP OR
 TENDER FUNDS

Sold To: 10000215303
 VERDE ELECTRIC
 89 EDISON AVENUE
 MT VERNON, NY, 10550

Ship To : Broadway Traffic Signal Improvements,10005427450
 BROADWAY
 NEWBURGH, NY, 12550
Job Site Contact: anthony mauriello
Job Site Phone:
Map #:

10:44 AM

Ordered By: GEORGE CARUSO

Contact Phone:

| Quote Number | | Quote Date | Valid Until | Request Date | Sales Person | |
|--------------|--------------|--|--------------|-----------------|--------------|-------------|
| 68680989 | | 09/29/2025 | 10/06/2025 | 09/29/2025 | Scheer, H | |
| Terms | | Shipping Method | Quote Name | Customer PO | Created By | |
| N30D | | 10. WCD Common Carrier | ADA TILES | ADA TILES | Scheer, H | |
| SEQ | Part# H/M | Description | Ord Quantity | U/M Unit WT | Price COO | Amount |
| 10 | 546CI230WSPA | 24"X30" PATINA CAST IRON WET SET TUFTILE | 116 | EA 47.77 LBS | \$133.23 | \$15,454.68 |
| 20 | SHIPPING | SHIPPING AND HANDLING | 1 | EA 0 LBS | \$570.00 | \$570.00 |

| | |
|------------------------|-------------|
| Shipped amount | \$16,024.68 |
| Order charges | \$0.00 |
| Tax amount | \$0.00 |
| Lumber Tax rate/amount | 1.00% |
| Quote total | \$16,024.68 |

Shipped Weight: 5,541.32 Customer acceptance signature: _____ Date : _____

ALL ITEMS AND QUANTITIES REQUIRE CUSTOMER REVIEW AND APPROVAL
AVAILABILITY AND LEAD TIMES ARE SUBJECT TO CHANGE
SPECIAL ORDERED ITEMS ARE SUBJECT TO MANUFACTURER APPROVAL PRIOR TO RETURN.
QUOTE IS SUBJECT TO EXPIRATION AS INDICATED IN THE ABOVE 10/06/2025 DATE.

The White Cap Family of Brands includes All-Tex Waterproofing Solutions, Harmac, Kenseal, Marvel Building & Masonry Supply, MASONPRO, and Williams Equipment & Supply. Learn more at About.WhiteCap.com.

Note: Due to volatility in the steel market from the recent Section 232 decision, domestic supply constraints and active trade negotiations, pricing is subject to change on a daily basis. Please review your pricing and contact your sales associate immediately to secure products and pricing.

WHITE CAP RESERVES THE RIGHT TO ADJUST PRICES TO REFLECT THE IMPACT OF ANY TARIFFS, DUTIES, OR SIMILAR GOVERNMENTAL CHARGES IMPOSED OR INCREASED AFTER THE DATE OF THIS QUOTE BUT PRIOR TO EXPIRATION.



SWENSON GRANITE COMPANY LLC
 369 NO. STATE STREET - CONCORD, NH 03301
 (603) 224-1637 - FAX (603) 227-9541



GRANITE PROPOSAL

| | | | | | | |
|-------|------------|--------------------|--|---------|--|---------------------|
| Date: | 2025/05/01 | approx. Ship Date: | | QUOTE # | | REVISED PIN 8005.26 |
|-------|------------|--------------------|--|---------|--|---------------------|

CUST: VERDE ELECTRIC

PROJECT: PEDESTRIAN IMPROVEMENTS
 NEWBURGH, NEW YORK

Attn:

LOCATION: NEWBURGH, NEW YORK

| LIGHT GRAY GRANITE | | | | Unit | Total | no. | |
|--------------------|--------|--|------------|-------------|--------|---------|-----------|
| Quantity | Unit | Description | Unit Price | Total | Weight | Weight | of trucks |
| 65 | LF +/- | 6" x 18" (+/-1") flush over 10' R | \$40.00 | \$2,600.00 | 135 | 8,775 | 0.2 |
| 191 | LF +/- | 6" x 18" (+/-1") Flush straight, random lengths | \$25.65 | \$4,894.88 | 125 | 23,854 | 0.5 |
| 9 | EA +/- | 6" x 18" (+/-1") transition 4'-0" straight | \$127.60 | \$1,148.40 | 500 | 4,500 | 0.1 |
| 22 | EA +/- | 6" x 18" (+/-1") transition 5'-0" straight | \$153.25 | \$3,371.50 | 625 | 13,750 | 0.3 |
| 2 | EA +/- | 6" x 18" (+/-1") transition 7'-0" straight | \$204.55 | \$409.10 | 875 | 1,750 | 0.0 |
| 1567 | LF +/- | 6" x 18" (+/-1") Vertical straight, random lengths | \$25.65 | \$40,187.14 | 125 | 195,844 | 4.4 |
| 6 | LF +/- | 6" x 18" (+/-1") Vertical under 5' R | \$64.10 | \$405.97 | 142 | 899 | 0.0 |
| 94 | LF +/- | 6" x 18" (+/-1") Vertical 5' R to 10' R | \$47.35 | \$4,450.90 | 135 | 12,690 | 0.3 |
| 2 | LF +/- | 6" x 18" (+/-1") Vertical over 10' R | \$40.00 | \$73.33 | 135 | 247 | 0.0 |
| 631 | LF +/- | 6" x 18" (+/-1") w/ 4" X 4" Bevel straight, random lengths | \$33.65 | \$21,216.33 | 125 | 78,813 | 1.8 |
| 174 | LF +/- | 6" x 18" (+/-1") w/ 4" X 4" Bevel under 5' R | \$82.30 | \$14,333.92 | 142 | 24,732 | 0.5 |
| 896 | LF +/- | 6" x 18" (+/-1") w/ 4" X 4" Bevel over 10' R | \$40.00 | \$35,826.67 | 135 | 120,915 | 2.7 |
| 32 | EA +/- | MGC-FLUSH 25' RAD - 5' | \$338.50 | \$10,832.00 | 650 | 20,800 | 0.5 |
| 1 | EA +/- | MGC-VGC 2' RAD - 4'4" | \$406.35 | \$406.35 | 710 | 710 | 0.0 |
| 25 | EA +/- | MGC-FLUSH 5' STRAIGHT | \$218.25 | \$5,456.25 | 625 | 15,625 | 0.3 |
| 2 | EA +/- | MGC-FLUSH 20' RAD - 5' | \$250.00 | \$500.00 | 675 | 1,350 | 0.0 |
| 1 | EA +/- | MGC-FLUSH 5' RAD - 5' | \$369.25 | \$369.25 | 675 | 675 | 0.0 |
| 1 | EA +/- | MGC-FLUSH 4' RAD - 4' | \$305.40 | \$305.40 | 560 | 560 | 0.0 |
| 1 | EA +/- | MGC-VGC 5' STRAIGHT TRANS | \$369.25 | \$369.25 | 625 | 625 | 0.0 |
| 12 | EA +/- | DELIVERIES | \$1,300.00 | \$15,600.00 | | | |

Subtotal: \$162,756.62
 (if applicable) Tax: _____
Total: \$162,756.62

NOTES:

1. Curbing is sawn top/bottom/ends with split front/back.
2. All material must be delivered or picked up within 45 days of need date provided by customer. If not, order will be subject to a 5% price increase.
3. Quote/prices are valid for 30 days
4. Customer is responsible for unloading
5. Customer is responsible to review and confirm our takeoff quantities or provide take off quantities.
6. Delivery fees may be subject to change.
7. Timbers \$13.00 EA. Credit will be issued when returned.
8. All pricing is **CONFIDENTIAL**.

Prices are: _____ F.O.B. Quarry
 _____ Trucking by Swenson
 _____ XXXX F.O.B. Jobsite, full truckload cost
 _____ XXXX Trucking by others

PAYMENT TERMS - C.O.D. OR APPROVED CREDIT

SWENSON GRANITE WORKS, LLC
 Leslie Shea-Manager Granite Curbing Sales

Accepted by: _____
 Company: _____
 Date: _____



OFFER

Cranesville Block Co., Inc.
 1250 Riverfront Center
 Amsterdam, NY 12010
 www.cranesville.com

Phone: 518-684-6000
 Dispatch: 518-684-6085
 Sales: 518-684-6078
 Sales Fax: 518-684-0128
 Credit: 518-684-6004

Ready Mixed Concrete – Aggregates – Masonry Units – Precast – Masonry Supplies

Customer Name Verde Electric
 Attention Tony
 Office Phone (914) 664-7000
 Cell Phone 845-337-9903
 Email albtoney@gmail.com
 Fax (914) 668-7997
 Yards 940
 Quote Number 00010099

Project Name Newburgh Broadway Recycling
 Project Address tbd
 Project Address(Cont'd) Newburgh, NY
 Quote Date 2/24/2025
 Expiration Date 12/31/2025
 Project Salesman Bill Cobey
 Salesman Mobile 845-313-0626
 Salesman Email wcobey@cranesville.com
 Sales Assoc. Patti Bieniek
 Sales Assoc. Phone 518-684-6119
 Sales Assoc. Email pbieniek@cranesville.com

| Quantity | Product | Line Item Description | Sales Price | UM |
|----------|------------------|--|-------------|----|
| 140.00 | Class A Concrete | | \$171.00 | CY |
| 690.00 | Class D Concrete | Excludes fiber or water reducer | \$184.00 | CY |
| 1.00 | Class D Concrete | Includes 1.5 lbs fiber and water reducer (sidewalks) | \$199.45 | CY |

***Due to the potential disruption in the cement supply chain, we reserve the right to requote as necessary.**

Above mixes are designed to have a 2"- 4" slump.

If a 4"- 6" slump is required a Midrange will need to be used at additional price listed below
 If a 7"-9" slump is required a Super Plasticizer will need to be used at additional price listed below
 Plants are NYSDOT approved; not NRMCA.

Please see the Terms & Conditions on the last page of this Offer.

MINIMUM OF A 6% INCREASE ON ALL BELOW PRODUCTS FOR EACH SUBSEQUENT YEAR.



Peckham Industries, Inc.
 172 Prospect Hill Rd, Brewster, NY 10509
 (914) 949-2000

Job Description: BROADWAY TRAFFIC SIG IMP - NEWBURGH

*** PRICING IS ONLY VALID FOR 30 DAYS FROM QUOTE DATE ***

| | | | |
|-----------------------------|-------------------|------------------------|---------------------------------|
| Quote Date: | 02/10/2025 | Customer: | Verde Electric Maintenance Inc. |
| Job Completion Date: | | | 89 Edison Avenue |
| Quote Expiration: | 03/02/2025 | | Mount Vernon, NY, 10550 |
| Project Location: | | Project Contact Name: | TONY MAVRA |
| Asphalt Index Type: | | Project Phone No: | 845-337-9903 |
| Asphalt Base Price: | | Project Fax No: | |
| Salesman Information | | Project Contact Email: | ALBTONY@GMAIL.COM |
| Name: | Joe Tetz | Job No: | |
| Phone: | | P.O. No: | |
| Mobile: | | Property Owner | |
| Email: | jtez3@peckham.com | Name: | |
| Quote ID: | Q-11772 | Street: | |
| | | City, State Zip: | |

| QTY | UOM | Product Description / DOT Item Code | Unit Price | | Extended Total | |
|------|------|--|----------------------------|-----------|----------------|-----------|
| | | | FOB | Delivered | FOB | Delivered |
| 1 | Tons | 4900 - Tipping Fee Concrete Middletown HMA | \$12.00 | - | \$12.00 | - |
| 1 | Tons | 4898 - TIPPING FEE MILLINGS Middletown HMA | \$12.00 | - | \$12.00 | - |
| 85 | Tons | 1204 - SUPERPAVE 19 MM (WMA) - 64S-22 Middletown HMA | \$91.00 | - | \$7,735.00 | - |
| 88 | Tons | 1208 - SUPERPAVE 9.5 MM (WMA) 64S-22 Middletown HMA | \$94.00 | - | \$8,272.00 | - |
| 1650 | Tons | 1300 - 304. - ITEM 4 Chester Quarry | \$16.50 | - | \$27,225.00 | - |
| 260 | Tons | 1306 - 203.07 SELECT GRANULAR FILL (M Chester Quarry | \$16.50 | - | \$4,290.00 | - |
| | | | Total | | \$47,546.00 | - |
| | | | Total including tax | | \$51,409.11 | - |

special note

SUPERPAVE QUOTED WITH 64S-22 AND WMA IF 64E OIL IS NEEDED PLEASE ADD 9.00 PER TON.
 ONLY CLEAN MILLINGS WILL BE ACCEPTED

ALL PRICING EXPIRES 12/31/25

Salesperson Signature: _____

Customer Signature: _____

Name: _____ Date: _____

Name: _____ Date: _____

WHITE CAP ON ACCOUNT



511 - Newington CT (AHH) (PZ10)
 91 Holmes Rd
 Newington, CT, 06111
 (860) 665-9400

QUOTE

67755862

THIS IS A QUOTE ONLY DO NOT SHIP OR
 TENDER FUNDS

Sold To: 10000215303
 VERDE ELECTRIC
 89 EDISON AVENUE
 MT VERNON, NY, 10550

Ship To : Broadway Traffic Signal Improvements,10005427450
 BROADWAY
 NEWBURGH, NY, 12550
 Job Site Contact: ANTHONY ANTHONY
 Job Site Phone: 914-652-3908
 Map #:

12:45 PM

Ordered By: ANTHONY ANTHONY

Contact Phone: 914-6523908

| Quote Number | | Quote Date | Valid Until | Request Date | Sales Person | |
|--------------|--------------|---|--------------|-----------------|--------------|-------------|
| 67755862 | | 08/12/2025 | 08/19/2025 | 08/12/2025 | Scheer, H | |
| Terms | | Shipping Method | Quote Name | Customer PO | Created By | |
| N30D | | 2. Our Truck | BROADWAY | broadway | Scheer, H | |
| SEQ | Part# H/M | Description | Ord Quantity | U/M Unit WT | Price COO | Amount |
| 10 | 434666G510 | 6"X6" W2.9 6GA 5'X10' WIRE MESH MAT | 1100 | EA 20.69 LBS | \$17.43 | \$19,173.00 |
| 20 | 199EB124010 | 1/2"X4"X10' FIBER EXPANSION BOARD 100FT/BUNDLE | 7500 | FT .32 LBS | \$0.38 | \$2,850.00 |
| 30 | 505VC12 | 1/2"X10' TOP VOID CAP SOLD/FOOT | 7400 | FT .08 LBS | \$0.37 | \$2,738.00 |
| 40 | 3392SPF2416 | 2"X4"X16' #2 SPF LUMBER | 200 | EA 18.66 LBS | \$12.79 | \$2,558.00 |
| 50 | 339CDX3448 | 3/4"X4'X8' CDX PLYWOOD 23/32" 18MM | 80 | EA 60 LBS | \$34.56 | \$2,764.80 |

| | | |
|------------------------|-------|-------------|
| Shipped amount | | \$30,083.80 |
| Order charges | | \$0.00 |
| Tax amount | | \$0.00 |
| Lumber Tax rate/amount | 1.00% | \$0.00 |
| Quote total | | \$30,083.80 |

Adjustments for #163 - 2022 Chevy Silverado 2500 Pick up Truck in All Saved Models

March 4, 2026

Chevrolet SILVERADO 2500HD 4X4 DIESEL
Light Duty Trucks

Size Class:
3
Weight:
N/A

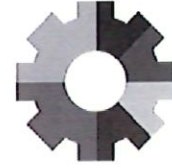

Configuration for SILVERADO 2500HD 4X4 DIESEL

Power Mode **Diesel** Wheelbase **149.4 Inches**
Gross Vehicle Weight Rating **11200 Pounds**

Blue Book Rates

** FHWA Rate is equal to the monthly ownership cost divided by 176 plus the hourly estimated operating cost.

| | Ownership Costs | | | | Estimated Operating Costs Hourly USD \$19.35 | FHWA Rate** |
|---------------------------------------|-----------------------|-----------------------|---------------------|--------------------|--|-----------------------|
| | Monthly | Weekly | Daily | Hourly | | Hourly USD \$41.11 |
| Published Rates | USD \$3,830.00 | USD \$1,075.00 | USD \$270.00 | USD \$41.00 | | |
| Adjustments | | | | | | |
| Region (100%) | - | - | - | - | | |
| Model Year (2022: 97.06%) | (USD \$112.73) | (USD \$31.64) | (USD \$7.95) | (USD \$1.21) | | |
| Adjusted Hourly Ownership Cost (100%) | - | - | - | - | | |
| Hourly Operating Cost (100%) | | | | | - | |
| Total: | USD \$3,717.27 | USD \$1,043.36 | USD \$262.05 | USD \$39.79 | USD \$19.35 | USD \$40.47 |

Non-Active Use Rates

| | Hourly |
|--------------|-------------|
| Standby Rate | USD \$12.74 |
| Idling Rate | USD \$28.85 |

Rate Element Allocation

| Element | Percentage | Value |
|-----------------------------|------------|-------------------|
| Depreciation (ownership) | 27.57% | USD \$1,055.91/mo |
| Overhaul (ownership) | 39.7% | USD \$1,520.38/mo |
| CFC (ownership) | 16.48% | USD \$631.24/mo |
| Indirect (ownership) | 16.25% | USD \$622.46/mo |
| Fuel (operating) @ USD 3.83 | 39.95% | USD \$7.73/hr |

Revised Date: 1st quarter 2026

These are the most accurate rates for the selected Revision Date(s). However, due to more frequent online updates, these rates may not match Rental Rate Blue Book® Print. Visit the Cost Recovery Product Guide on our Help page for more information.

The equipment represented in this report has been exclusively prepared for (rdleonardo@verdeelectric.com)

Adjustments for Rack/Box Truck 156 in All Saved Models
Miscellaneous 6X6 70KGWV DSL
 On-Highway Truck Tractors

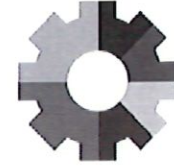
 Size Class:
60,001 lbs & Over
 Weight:
 N/A

Configuration for 6X6 70KGWV DSL

| | | | |
|------------------------------|--------------------|------------|-----------------|
| Axle Configuration | 6X6 | Horsepower | 450.0 hp |
| Maximum Gross Vehicle Weight | 70000.0 lbs | Power Mode | Diesel |

Blue Book Rates

** FHWA Rate is equal to the monthly ownership cost divided by 176 plus the hourly estimated operating cost.

| | Ownership Costs | | | | Estimated Operating Costs Hourly USD \$61.38 | FHWA Rate** |
|---------------------------------------|-----------------------|-----------------------|---------------------|--------------------|--|-----------------------|
| | Monthly | Weekly | Daily | Hourly | | Hourly USD \$86.75 |
| Published Rates | USD \$4,465.00 | USD \$1,250.00 | USD \$315.00 | USD \$47.00 | | |
| Adjustments | | | | | | |
| Region (New York: 104%) | USD \$178.60 | USD \$50.00 | USD \$12.60 | USD \$1.88 | | |
| Model Year (2023: 99.94%) | (USD \$2.63) | (USD \$0.74) | (USD \$0.19) | (USD \$0.03) | | |
| Adjusted Hourly Ownership Cost (100%) | - | - | - | - | | |
| Hourly Operating Cost (100%) | | | | | - | |
| Total: | USD \$4,640.97 | USD \$1,299.26 | USD \$327.41 | USD \$48.85 | USD \$61.38 | USD \$87.75 |

Non-Active Use Rates

| | Hourly |
|--------------|-------------|
| Standby Rate | USD \$16.50 |
| Idling Rate | USD \$68.61 |

Rate Element Allocation

| Element | Percentage | Value |
|-----------------------------|------------|-------------------|
| Depreciation (ownership) | 42.27% | USD \$1,897.24/mo |
| Overhaul (ownership) | 37.42% | USD \$1,670.85/mo |
| CFC (ownership) | 9.36% | USD \$418.00/mo |
| Indirect (ownership) | 10.95% | USD \$488.91/mo |
| Fuel (operating) @ USD 3.83 | 68.82% | USD \$42.24/hr |

Revised Date: 1st quarter 2026

These are the most accurate rates for the selected Revision Date(s). However, due to more frequent online updates, these rates may not match Rental Rate Blue Book® Print. Visit the Cost Recovery Product Guide on our Help page for more information.

The equipment represented in this report has been exclusively prepared for (rdileonardo@verdeelectric.com)

Adjustments for Rack/Box Truck 156 in All Saved Models

 Miscellaneous 6X6 70KGVW DSL
 On-Highway Truck Tractors

 Size Class:
60,001 lbs & Over
 Weight:
 N/A

Configuration for 6X6 70KGVW DSL

| | | | |
|------------------------------|--------------------|------------|-----------------|
| Axle Configuration | 6X6 | Horsepower | 450.0 hp |
| Maximum Gross Vehicle Weight | 70000.0 lbs | Power Mode | Diesel |

Blue Book Rates

** FHWA Rate is equal to the monthly ownership cost divided by 176 plus the hourly estimated operating cost.

| | Ownership Costs | | | | Estimated Operating Costs Hourly | FHWA Rate** Hourly |
|---------------------------------------|-----------------------|-----------------------|---------------------|--------------------|-------------------------------------|-----------------------|
| | Monthly | Weekly | Daily | Hourly | | |
| Published Rates | USD \$4,465.00 | USD \$1,250.00 | USD \$315.00 | USD \$47.00 | USD \$61.38 | USD \$86.75 |
| Adjustments | | | | | | |
| Region (New York: 104%) | USD \$178.60 | USD \$50.00 | USD \$12.60 | USD \$1.88 | | |
| Model Year (2023: 99.94%) | (USD \$2.63) | (USD \$0.74) | (USD \$0.19) | (USD \$0.03) | | |
| Adjusted Hourly Ownership Cost (100%) | - | - | - | - | | |
| Hourly Operating Cost (100%) | | | | | - | |
| Total: | USD \$4,640.97 | USD \$1,299.26 | USD \$327.41 | USD \$48.85 | USD \$61.38 | USD \$87.75 |

Non-Active Use Rates

| | Hourly |
|--------------|-------------|
| Standby Rate | USD \$16.50 |
| Idling Rate | USD \$68.61 |

Rate Element Allocation

| Element | Percentage | Value |
|-----------------------------|------------|-------------------|
| Depreciation (ownership) | 42.27% | USD \$1,887.24/mo |
| Overhaul (ownership) | 37.42% | USD \$1,670.85/mo |
| CFC (ownership) | 9.36% | USD \$418.00/mo |
| Indirect (ownership) | 10.95% | USD \$488.91/mo |
| Fuel (operating) @ USD 3.83 | 68.82% | USD \$42.24/hr |

Revised Date: 1st quarter 2026

These are the most accurate rates for the selected Revision Date(s). However, due to more frequent online updates, these rates may not match Rental Rate Blue Book® Print. Visit the Cost Recovery Product Guide on our Help page for more information.

The equipment represented in this report has been exclusively prepared for (rdleonardo@verdeelectric.com)

Adjustments for pc-78us-10 in All Saved Models

Komatsu PC78US-10
Crawler Mounted Hydraulic Excavators



Size Class:
6.5 - 8.4 mt
Weight:
N/A

Configuration for PC78US-10

Horsepower **65.5 hp** Operating Weight **17747.0 lbs**
Power Mode **Diesel**

Blue Book Rates

** FHWA Rate is equal to the monthly ownership cost divided by 176 plus the hourly estimated operating cost.

| | Ownership Costs | | | | Estimated Operating Costs Hourly USD \$17.63 | FHWA Rate** Hourly USD \$55.16 |
|---------------------------------------|-----------------------|-----------------------|---------------------|--------------------|--|--------------------------------------|
| | Monthly | Weekly | Daily | Hourly | | |
| Published Rates | USD \$6,605.00 | USD \$1,850.00 | USD \$465.00 | USD \$70.00 | | |
| Adjustments | | | | | | |
| Region (100%) | - | - | - | - | | |
| Model Year (2022: 99.94%) | (USD \$4.19) | (USD \$1.17) | (USD \$0.30) | (USD \$0.04) | | |
| Adjusted Hourly Ownership Cost (100%) | - | - | - | - | | |
| Hourly Operating Cost (100%) | | | | | - | |
| Total: | USD \$6,600.81 | USD \$1,848.83 | USD \$464.70 | USD \$69.96 | USD \$17.63 | USD \$55.13 |

Non-Active Use Rates

| | Hourly |
|--------------|-------------|
| Standby Rate | USD \$20.95 |
| Idling Rate | USD \$42.27 |

Rate Element Allocation

| Element | Percentage | Value |
|-----------------------------|------------|-------------------|
| Depreciation (ownership) | 31.78% | USD \$2,098.95/mo |
| Overhaul (ownership) | 44.15% | USD \$2,916.09/mo |
| CFC (ownership) | 15.44% | USD \$1,019.92/mo |
| Indirect (ownership) | 8.63% | USD \$570.03/mo |
| Fuel (operating) @ USD 3.83 | 27.06% | USD \$4.77/hr |

Revised Date: 1st quarter 2026

These are the most accurate rates for the selected Revision Date(s). However, due to more frequent online updates, these rates may not match Rental Rate Blue Book® Print. Visit the Cost Recovery Product Guide on our Help page for more information.

The equipment represented in this report has been exclusively prepared for (rdileonardo@verdeelectric.com)



Insurance | Risk Management | Consulting

30 Century Hill Drive, Suite 200
Latham, NY 12110
USA

518-869-3535
www.ajg.com

January 26, 2026

Verde Electric Maintenance Corporation.
89 Edison Avenue
Mount Vernon, NY 10550

**Re: Workers Compensation Experience Modifications
Verde Electric Maintenance Corporation.**

Dear Tricia:

Please allow this letter to acknowledge and confirm the Workers Compensation Experience Modification for the above.

The EMR's are as follows:

| <u>Effective Year</u> | <u>Experience Modification</u> |
|-----------------------|--------------------------------|
| 10/30/25 to 10/30/26 | 1.00 |

We trust you will find the enclosed in order but should you have any questions please contact our office.

Sincerely,

Julie Kaiser
Client Service Manager



Insurance | Risk Management | Consulting

March 4, 2026

New York State Department of Transportation
50 Wolf Road
Albany, NY 12232

Re: Insured - Verde Electric Corp - 89 Edison Avenue, Mount Vernon, NY 10550

General Liability/ Umbrella Insurance Rate Calculation Based on Sales:

| | | |
|---|----------------------------|-----------------------|
| General Liability (per \$100 of payroll) | \$30.65 | See below for support |
| Lead Umbrella (per \$100 of payroll) | \$5.50 | See below for support |
| First Umbrella (per \$100 of payroll) | \$4.00 | See below for support |
| Second Umbrella (per \$100 of payroll) | \$3.50 | See below for support |
| Total | \$43.65 \$40.15 | |
| Per \$100 of payroll | | |
| Verde Electric GL & Umbrella Rate | 43.65% 40.15% | |

General Liability

Insuring Company: Traveler Indemnity Company.

AM. Best Rating: A++XV (Admitted)

Policy Number: VTC2KCO3X459385IND25

Policy Expires: 10/31/2026

Limit of Liability:

General Aggregate: \$4,000,000

Products Completed Operations Aggregate: \$4,000,000

Personal & Advt. Injury: \$2,000,000

Each Occurrence: \$ 2,000,000

Damage to Rented Premise: \$300,000

Rate- \$30.65 per \$100 of Payroll



Insurance | Risk Management | Consulting

Excess Umbrella Liability

Insuring Company: Starr Indemnity & Liability Company Company.

AM. Best Rating: A++XV (Admitted)

Policy Number: 1100588039251

Policy Expires: 10/31/2026

Limit of Liability:

General Aggregate: \$3,000,000

Each Occurrence: \$3,000,000

Rate- \$5.50 per \$100 of Payroll

Excess Umbrella Second

Insuring Company: Berkley Casualty Company

AM. Best Rating: A+XV (Admitted)

Policy Number: BCS880013440

Policy Expires: 10/31/2026

Limit of Liability:

General Aggregate: \$7,000,000

Each Occurrence: \$7,000,000

Rate- \$4.00 per \$100 of Payroll

Excess Umbrella Third

Insuring Company: Zurich Insurance Company & Liberty Insurance Underwriting

AM. Best Rating: A+XV (Admitted) and A XV (Admitted)

Policy Number: A E C 7 1 3 0 5 7 0 - 0 3 and 1 0 0 0 5 7 0 2 1 6 0 2

Policy Expires: 10/31/2026

Limit of Liability:

General Aggregate: \$10,000,000



Insurance | Risk Management | Consulting

Each Occurrence: \$10,000,000

Rate- \$3.50 per \$100 of Payroll

Workers Compensation

Insuring Company: Charter Oak Fire Ins. Co. (Travelers)

AM. Best Rating: A++XV

Policy Number: UB4X4902572525H

Policy Expires: 10/31/2026

Limit of Liability:

Each Accident: Statutory Disease

Policy Limit: Statutory

Disease: Each Employee: Statutory

Exposure: Electrical Wiring Rate: \$12.38 per \$100 of Payroll: Conduit Rate - \$16.74 per \$100

Average Rate: \$14.56 per \$100 of Payroll (See Support Below)

| | Estimated Payroll | Rate per \$100 | Premium |
|-------------------|-----------------------|----------------|---------------------|
| Electrical Wiring | \$1,100,000.00 | 12.38% | \$136,111.80 |
| Conduit | \$1,300,909.00 | 16.74% | \$217,623.90 |
| Total: | \$2,400,000.00 | | \$353,735.70 |
| | | 14.56% | Blended Rate |

If you would like to speak with me directly please feel free to contact me. My email address is David_Brockmann@ajg.com; my office phone number is 518-533-6898 and my mobile phone number is 518- 330-1743.

David Brockmann

David Brockmann, Jr.
Area Vice President
Director of Construction Services
Arthur J. Gallagher Risk Management Services

Reset Form

NEW YORK STATE DEPARTMENT OF TRANSPORTATION COST ANALYSIS WORKSHEET (9/22)

Print Form

Contract D# **036472**

Change Order # **001**

Field Change Payment #

CO Item Qty **2**

Section 1 - Existing Contract Item

Use the Item Analysis Report and CONR 22 Composite Report in BI to fill out the below information. Follow Added Work Cost Analysis Decision Flow Chart.

Item Spec No

Unit Bid Price

Bid Qty

Current Contract Qty

Major Item

Minor Item

75% Threshold

Renegotiation Threshold

125% Threshold

(200% and \$5,000 over original contract amount)

High Bid Item (over 125%) Yes No

Section 2 - New Contract Item or Continuation of Existing Item

New Item Spec No **950.0403A**

Renegotiated Qty **2**

Contractor Quoted Unit Price **\$9,757.19**

Method Chosen:

- Original Bid Price Acceptable?
- Contractor agrees to work at the Original Contract Bid Price adjusted for documented changes in material costs, equipment rates, mobilization, and/or site conditions, and bid price is reasonable compensation for the quantity of added work: include letter from contractor, and supporting documentation for adjustments (need price analysis) on CO Header
- Weighted Average Price (WAP) Comparison (must have at least 3 contracts)

Pay Item Catalog Date Range to

PIC Qty Range to N/A

Regional WAP Statewide WAP

Printout of PIC w/ Qty Range, dates, prices attached?

- Comparison to Average of 3 Lowest Bidders (on contract, not item)

Average Price **\$0.00** Bidder 1

Bidder 2

Bidder 3

Printout of 3 Lowest Bidders on the Contract attached?

- Price Analysis

MURK 26/27 Price Analysis Worksheet attached and all documentation attached?

- Force Account Work (FAW)

FE (Force Estimate) Estimate of Labor, Materials, and Equipment work up included?

FAW (Final) Included with all MURK forms and documentation attached?

Project Conditions/Variance Explanation attached?

Signature *Kelly A. Vito*

Date **Mar 25, 2026**



89 Edison Avenue • Mt. Vernon, New York 10550
Phone 914-664-7000 • Facsimile 914-668-7997

April 27, 2026

WSP Field Office/Broadway TSP
1 Corwin Court, Room 102
Newburgh, NY 10550
Attn: Arlisa McGrath, EIC

RE: Contract Pins 8005.26 and 8758.75
Broadway Pedestrian and Traffic Signal Improvements
VEMC Job #8510 and 8530
Item No. 608.0101 – Concrete Sidewalk
Item No. 608.01050109 – Curb Ramp Configuration Type 1
Letter of Concurrence

Dear Arlisa:

Verde Electric Maintenance Corp. concurs with maintaining its original bid unit prices for any remaining contract quantities associated with the following items:

Item No.: 608.0101
Item Description: Concrete Sidewalk

Item No.: 608.01050109
Item Description: Curb Ramp Configuration Type 1

Verde acknowledges that these items represent major items and that the final quantities will be less than the originally estimated bid quantities.

Please do not hesitate to contact me if you have any questions.

Very truly yours,
Verde Electric Maintenance Corp.

A handwritten signature in blue ink, appearing to read 'Robert Craig', is written over the signature line.

Robert Craig
Vice President



89 Edison Avenue • Mt. Vernon, New York 10550
Phone 914-664-7000 • Facsimile 914-668-7997

February 12, 2026

WSP Field Office/Broadway TSP
1 Corwin Court, Room 102
Newburgh, NY 10550
Attn: Arlisa McGrath, EIC

RE: Contract Pins 8005.26 and 8758.75
Broadway Pedestrian and Traffic Signal Improvements
VEMC Job #8510 and 8530
Item No. 206.05A – Test Pit Excavation (Changed Condition)
Letter of Concurrence

Dear Arlisa:

Verde Electric Maintenance Corp. accepts the agreed price for:

| | |
|-------------------|---|
| Item No.: | 206.05A |
| Item Description: | Test Pit Excavation (Changed Condition) |
| Quantity: | 13ea |
| Unit Price: | \$8,416.08 |
| Total Extension: | \$109,409.04 |

Please do not hesitate to contact me if you have any questions.

Very truly yours,
Verde Electric Maintenance Corp.

Robert Craig
Vice President

NEW YORK STATE DEPARTMENT OF TRANSPORTATION

Agreed Price Worksheet - Prime Contractor

Contract: 8005.26
8758.75 Item No.: 206.05 Quantity: 13.00 Units: EA
Item Description: Test Pit (additional test pits for traffic signal pole foundations)

| Trade | Reg | | | Fringe | | |
|--------------------|-------|-----------|-------------|--------|----------|-------------|
| | Hours | Wage Rate | Cost | Hours | Rate | Cost |
| General Foreman | 70.00 | \$ 67.14 | \$ 4,699.80 | 70.00 | \$ 41.85 | \$ 2,929.50 |
| Journeyman Lineman | 70.00 | \$ 55.95 | \$ 3,916.50 | 70.00 | \$ 40.24 | \$ 2,816.80 |
| Journeyman Lineman | 70.00 | \$ 55.95 | \$ 3,916.50 | 70.00 | \$ 40.24 | \$ 2,816.80 |
| Groundman DMO | 70.00 | \$ 50.36 | \$ 3,525.20 | 70.00 | \$ 37.88 | \$ 2,651.60 |
| | | | | | | |
| | | | | | | |
| | | | | | | |

Wages \$16,058.00 Fringes \$11,214.70

If Fringes are paid directly to employee via cash or check, Enter value here: \$ 0.00
Worker's Compensation Rate (%): 12.00 %

Total of Wages and Fringes: \$27,272.70
Workers Compensation: \$ 1,926.96
Standard Labor Markup: \$ 2,007.25
Fringe Benefit Markup: \$ 0.00
Labor Total: \$31,206.91

(The Contractor shall submit an insurance policy declaration / rate page from its insurer to validate the Workers Comp insurance rate based on an EMR of 1.0.)

| (B) MATERIALS | | | | | | | | | |
|-------------------------|-------|------------|-----------|------------|--------------------|-------|------------|-----------|--|
| Description | Units | # of Units | Cost/Unit | Cost | Description | Units | # of Units | Cost/Unit | Cost |
| Item 4 | Tn | 98.00 | \$29.00 | \$2,842.00 | Cold Patch Asphalt | Bg | 29.00 | \$19.75 | \$572.75 |
| | | | | | | | | | |
| | | | | | | | | | |
| | | | | | | | | | |
| Materials Total: | | | | | | | | | \$3,414.75 |

| (C) EQUIPMENT | | | | | | | |
|-------------------------|-------|-----------|------------|-------------------|-------|-----------|---|
| Description | Hours | FHWA Rate | Cost | Description | Hours | FHWA Rate | Cost |
| Dump Truck | 13.00 | \$101.78 | \$1,323.14 | 10-Ton Trailer | 26.00 | \$17.58 | \$457.08 |
| Pickup Truck | 70.00 | \$27.96 | \$1,957.20 | Komatsu Excavator | 26.00 | \$53.33 | \$1,386.58 |
| 175 CFM Aircompressor | 13.00 | \$14.03 | \$182.39 | Box Truck | 70.00 | \$85.13 | \$5,959.10 |
| | | | | Pavement Breaker | 13.00 | \$1.79 | \$23.27 |
| Equipment Total: | | | | | | | \$11,288.76 |

| (D) SERVICES | | | | | | | |
|------------------------|------------|-------------|--------------|--------------------|------------|-------------|---|
| Description / Type | # of Units | Cost / Unit | Cost | Description / Type | # of Units | Cost / Unit | Cost |
| Hydrovac | 11 | \$ 4,200.00 | \$ 46,200.00 | | | | |
| | | | | | | | |
| Services Total: | | | | | | | \$46,200.00 |

| (E) OVERHEAD & PROFIT | OH & Profit % | Cost |
|--------------------------------------|---------------|-------------|
| Labor, Materials, & Equipment Total: | 20.00 | \$ 9,182.08 |
| Services: | 5.00 | \$ 2,310.00 |

Overhead & Profit Total: \$11,492.08

(F) INSURANCE
Enter rate here if based on payroll: 36.16 %
Payroll Based Cost Basis: \$ 16,058.00
Enter rate here if based on sales:
Sales Based Cost Basis: \$ 0.00
Insurance Total: \$ 5,806.57

Item Total: \$ 109,409.08 Unit Price: \$ 8,416.08 per EA

Robert Craig 6-11-25
Contractor's Rep Name Signature Date
Artlisa McGrath 2/12/26
Engineer-in-Charge's Name Signature Date

VERDE ELECTRIC CORP LABOR RATE BREAKDOWN

EFFECTIVE DATES:

FROM: 5/6/2024
TO: 5/3/2025

TRADE CLASSIFICATION: GENERAL FOREMAN

UNION: NORTHEAST LINE CONST.
LOCAL NO: 1249

| | | Straight Time | Overtime & Saturday | Sunday |
|---|-------------|------------------|---------------------|------------------|
| 1 HOURLY RATE | | | | |
| | | \$ 67.14 | \$ 100.71 | \$ 134.28 |
| 2 FRINGES: | | | | |
| | RATE | | | |
| NEBF | 3.00% | \$ 2.01 | \$ 3.02 | \$ 4.03 |
| Insurance Fund | \$10.40 | \$ 10.40 | \$ 10.40 | \$ 10.40 |
| Pension Fund | \$14.50 | \$ 14.50 | \$ 14.50 | \$ 14.50 |
| Annuity Fund | \$6.00 | \$ 6.00 | \$ 6.00 | \$ 6.00 |
| Safety Training Fund | 3.25% | \$ 2.18 | \$ 3.27 | \$ 4.36 |
| NEAT | 0.75% | \$ 0.50 | \$ 0.76 | \$ 1.01 |
| NEIF | 0.50% | \$ 0.34 | \$ 0.50 | \$ 0.67 |
| NELCAF | 0.75% | \$ 0.50 | \$ 0.76 | \$ 1.01 |
| NLMCC | \$0.01 | \$ 0.01 | \$ 0.01 | \$ 0.01 |
| ** Holiday | \$5.41 | \$ 5.41 | \$ 5.41 | \$ 5.41 |
| TOTAL FRINGES: | | \$ 41.85 | \$ 44.62 | \$ 47.39 |
| 3 PAYROLL TAXES & INSURANCE | | | | |
| | RATE | | | |
| FICA (Social Security & Medicare) | 7.65% | \$ 5.14 | \$ 7.70 | \$ 10.27 |
| Federal Unemployment | 0.60% | \$ 0.40 | \$ 0.60 | \$ 0.81 |
| Metro Tax | 0.34% | \$ 0.23 | \$ 0.34 | \$ 0.46 |
| New York Unemployment | 7.03% | \$ 4.72 | \$ 7.07 | \$ 9.43 |
| Workers Comp | 7.80% | \$ 5.24 | \$ 5.24 | \$ 5.24 |
| General Liability | 15.50% | \$ 10.41 | \$ 15.61 | \$ 20.81 |
| TOTAL PAYROLL TAXES & INSURANCE: | | \$ 26.13 | \$ 36.57 | \$ 47.02 |
| 4 TOTAL LABOR RATE, FRINGES, TAXES & INSURANCE | | | | |
| | | \$ 135.12 | \$ 181.91 | \$ 228.69 |

** Holiday computed as 80 hour cost divided by 1,920 (est. 48 week work year)

VERDE ELECTRIC CORP LABOR RATE BREAKDOWN

EFFECTIVE DATES:

FROM: 5/6/2024
TO: 5/3/2025

TRADE CLASSIFICATION:

JOURNEYMAN LINEMAN/TECHNICIAN

UNION:

NORTHEAST LINE CONST.

LOCAL NO:

1249

| | | Straight Time | Overtime & Saturday | Sunday |
|---|-------------|---------------|---------------------|-----------|
| 1 HOURLY RATE | | \$ 55.95 | \$ 83.93 | \$ 111.90 |
| 2 FRINGES: | | | | |
| | RATE | | | |
| NEBF | 3.00% | \$ 1.68 | \$ 2.52 | \$ 3.36 |
| Insurance Fund | \$10.40 | \$ 10.40 | \$ 10.40 | \$ 10.40 |
| Pension Fund | \$14.50 | \$ 14.50 | \$ 14.50 | \$ 14.50 |
| Annuity Fund | \$6.00 | \$ 6.00 | \$ 6.00 | \$ 6.00 |
| Safety Training Fund | 3.25% | \$ 1.82 | \$ 2.73 | \$ 3.64 |
| NEAT | 0.75% | \$ 0.42 | \$ 0.63 | \$ 0.84 |
| NEIF | 0.50% | \$ 0.28 | \$ 0.42 | \$ 0.56 |
| NELCAF | 0.75% | \$ 0.42 | \$ 0.63 | \$ 0.84 |
| NLMCC | \$0.01 | \$ 0.01 | \$ 0.01 | \$ 0.01 |
| ** Holiday | \$4.72 | \$ 4.72 | \$ 4.72 | \$ 4.72 |
| TOTAL FRINGES: | | \$ 40.24 | \$ 42.55 | \$ 44.86 |
| 3 PAYROLL TAXES & INSURANCE | | | | |
| | RATE | | | |
| FICA (Social Security & Medicare) | 7.65% | \$ 4.28 | \$ 6.42 | \$ 8.56 |
| Federal Unemployment | 0.60% | \$ 0.34 | \$ 0.50 | \$ 0.67 |
| Metro Tax | 0.34% | \$ 0.19 | \$ 0.29 | \$ 0.38 |
| New York Unemployment | 7.03% | \$ 3.93 | \$ 5.90 | \$ 7.86 |
| Workers Comp | 7.80% | \$ 4.36 | \$ 4.36 | \$ 4.36 |
| General Liability | 15.50% | \$ 8.67 | \$ 13.01 | \$ 17.34 |
| TOTAL PAYROLL TAXES & INSURANCE: | | \$ 21.77 | \$ 30.48 | \$ 39.18 |
| 4 TOTAL LABOR RATE, FRINGES, TAXES & INSURANCE | | \$ 117.97 | \$ 156.95 | \$ 195.94 |

* Benefits payable up to a maximum 40 hour week

** Holiday computed as 80 hour cost divided by 1,920 (est. 48 week work year)

VERDE ELECTRIC CORP LABOR RATE BREAKDOWN

EFFECTIVE DATES:

FROM: 5/6/2024
TO: 5/3/2025

TRADE CLASSIFICATION: DIGGING MACHINE OPER.

UNION: NORTHEAST LINE CONST.
LOCAL NO: 1249

| | | Straight Time | Overtime & Saturday | Sunday |
|---|-------------|---------------|---------------------|-----------|
| 1 HOURLY RATE | | \$ 50.36 | \$ 75.54 | \$ 100.72 |
| 2 FRINGES: | | | | |
| | RATE | | | |
| NEBF | 3.00% | \$ 1.51 | \$ 2.27 | \$ 3.02 |
| Insurance Fund | \$10.40 | \$ 10.40 | \$ 10.40 | \$ 10.40 |
| Pension Fund | \$14.50 | \$ 14.50 | \$ 14.50 | \$ 14.50 |
| Annuity Fund | \$4.50 | \$ 4.50 | \$ 4.50 | \$ 4.50 |
| Safety Training Fund | 3.25% | \$ 1.64 | \$ 2.46 | \$ 3.27 |
| NEAT | 0.75% | \$ 0.38 | \$ 0.57 | \$ 0.76 |
| NEIF | 0.50% | \$ 0.25 | \$ 0.38 | \$ 0.50 |
| NELCAF | 0.75% | \$ 0.38 | \$ 0.57 | \$ 0.76 |
| NLMCC | \$0.01 | \$ 0.01 | \$ 0.01 | \$ 0.01 |
| ** Holiday | \$4.31 | \$ 4.31 | \$ 4.31 | \$ 4.31 |
| TOTAL FRINGES: | | \$ 37.88 | \$ 39.96 | \$ 42.03 |
| 3 PAYROLL TAXES & INSURANCE | | | | |
| | RATE | | | |
| FICA (Social Security & Medicare) | 7.65% | \$ 3.85 | \$ 5.78 | \$ 7.71 |
| Federal Unemployment | 0.60% | \$ 0.30 | \$ 0.45 | \$ 0.60 |
| Metro Tax | 0.34% | \$ 0.17 | \$ 0.26 | \$ 0.34 |
| New York Unemployment | 7.03% | \$ 3.54 | \$ 5.31 | \$ 7.08 |
| Workers Comp | 7.80% | \$ 3.93 | \$ 3.93 | \$ 3.93 |
| General Liability | 15.50% | \$ 7.81 | \$ 11.71 | \$ 15.61 |
| TOTAL PAYROLL TAXES & INSURANCE: | | \$ 19.60 | \$ 27.43 | \$ 35.27 |
| 4 TOTAL LABOR RATE, FRINGES, TAXES & INSURANCE | | \$ 107.84 | \$ 142.93 | \$ 178.02 |

* Benefits payable up to a maximum 40 hour week
 ** Holiday computed as 80 hour cost divided by 1,920 (est. 48 week work year)



Quote

Quote: **NEWBURGH-24**
 Quote Date: 02/05/2025
 Expire Date: 03/07/2025
 Page 1 of 1

Customer: 1324 - Verde Electric
 Project: Broadway Ped. & Traffic Signal Imp. - City Newburgh
 Project: Broadway City of Newburgh
 Address: D036472 (PIN 8005.26) & D036489 (PIN 8758.75)

Salesperson: Michael Keahon
 914-291-3689

Customer Contact: Tony

Dakota Recycling

| Product | Quantity | Unit | Material Rate |
|----------------------|----------|------|---------------|
| CONCIN - Concrete In | 1.00 | CY | 25.00 |

Fishkill - Asphalt

| Product | Quantity | Unit | Material Rate |
|----------------------------|----------|------|---------------|
| 160 - 9.5<30 WM H026722541 | 90.00 | Tons | 93.00 |
| 162 - 19<30 WM H026722341 | 90.00 | Tons | 85.00 |

Fishkill Aggregate

| Product | Quantity | Unit | Material Rate | Freight Type | Freight Rate | Unit |
|---|----------|------|---------------|------------------|--------------|------|
| #2 - 3/4" Stone (Size 2) 623.12?? | 4.00 | Tons | 25.00 | Tri-Axle Trailer | 10.00 | Ton |
| ASPHIN - Asphalt In | 1.00 | Tons | 0.00 | | | |
| ITEM4 - Item 4 Type 1 304.11 | 1,905.00 | Tons | 19.00 | Tri-Axle Trailer | 10.00 | Ton |
| SELGRANFILL - Select Granular Fill 203.07 | 300.00 | Tons | 19.00 | Tri-Axle Trailer | 10.00 | Ton |

Comments / Notes:

ASPHALT WILL BE SUBJECT TO A LIQUID ASPHALT PRICE ADJUSTMENT.
 ASPHALT INDEX AT TIME OF BID IS = \$633.00 AUGUST 2024.
 T & L ITEM = PLEASE USE THE APPROPRIATE MIX PRICE ABOVE. THE T&L ITEM DOES NOT SPECIFY THE MIX.
 ALL PRICING IS BASED ON DAYTIME WORK (MONDAY - FRIDAY)
 623.12 CRUSHED STONE DID NOT SPECIFY THE SIZE. GAVE PRICING ON NYS #2 WHICH IS 3/4".
 STONE PRICING IS FOR 2025. FOR 2026, PLEASE ADD 6% TO THE MATERIAL AND HAUL RATE AND FOR EACH YEAR AFTER.
 HAUL RATES ARE BASED ON FULL LOADS. A FLAT RATE FEE WILL APPLY FOR ANYTHING LESS THAN A FULL LOAD.

Invoices not paid in full within 60 days from the invoice date will incur a monthly interest charge of 1.5%

Accepted by: _____
 Date: _____

Pricing is subject to change if this offer is not accepted within 30 days of the above date.
 - Asphalt concrete prices shall be adjusted based on the current asphalt price adjustment formula per NYSDOT/OGS/Municipal specifications applicable to this project
 - If applicable, this quote is subject to plant production quality adjustments. All upward pricing adjustments associated with this provision will be billed at the fixed unit prices set forth in the contract.
 - If applicable, this quote is subject to fuel adjustment charges based on the NYSOGS/DOT formula applicable to this project. All upward pricing adjustment associated with this provision will be forthcoming to Thalle Industries, Inc. and billed at fixed unit prices set forth in this contract.
 - If applicable, this quote is subject to the provision of EI 97-010 which refers to Section 402 Quality Control Asphalt Concrete and the new phase in Quantity Adjustment Factors. All upward pricing adjustments associated with this provision will be billed at the Prime Contractors Bid Price with the Adjustment Factor in Tons or Metric Tons.
 - All upward pricing adjustments shall inure to the benefit of Thalle Industries, Inc.
 - Quoted prices assume normal hours of operation, Monday through Friday. Additional charges will be assessed for night or weekend supply.
 - Acceptance of order by Thalle Industries, Inc. subject to terms and credit approvals.
 New York State Sales Tax, if applicable, required by law to be paid by the purchaser.

WHITE CAP[®] ON ACCOUNT



511 - Newington CT (AHH) (PZ10)
 91 Holmes Rd
 Newington, CT, 06111
 (860) 665-9400

QUOTE

65679184

**THIS IS A QUOTE ONLY DO NOT SHIP OR
 TENDER FUNDS**

Sold To: 10000215303
 VERDE ELECTRIC
 89 EDISON AVENUE
 MT VERNON, NY, 10550

Ship To : M92450579 89 EDISON AVENUE,10004992130
 89 EDISON AVENUE
 MOUNT VERNON, NY, 10550
Job Site Contact: ERIC #
Job Site Phone: 845-417-4041
Map #:

08:22 AM

Ordered By: richard boehn

Contact Phone: 914-6296843

| Quote Number | | Quote Date | Valid Until | Request Date | Sales Person | |
|--------------|--------------|---|--------------|------------------|--------------|----------|
| 65679184 | | 04/29/2025 | 05/06/2025 | 04/29/2025 | Scheer, H | |
| Terms | | Shipping Method | Quote Name | Customer PO | Created By | |
| N30D | | 2. Our Truck | job #8501 | job #8501 | Scheer, H | |
| SEQ | Part# H/M | Description | Ord Quantity | U/M Unit WT | Price COO | Amount |
| 10 | 850PP60C | INSTANT PERMANENT ROAD REPAIR ASPHALT PATCHING MATERIAL PERMA PATCH | 50 | EA 60 LBS | \$19.75 | \$987.50 |

| | |
|------------------------|-------------------|
| Shipped amount | \$987.50 |
| Order charges | \$0.00 |
| Tax amount | \$82.70 |
| Lumber Tax rate/amount | 1.00% \$0.00 |
| Quote total | \$1,070.20 |

Shipped Weight: 3,000.00 Customer acceptance signature: _____ Date : _____

ALL ITEMS AND QUANTITIES REQUIRE CUSTOMER REVIEW AND APPROVAL
AVAILABILITY AND LEAD TIMES ARE SUBJECT TO CHANGE
SPECIAL ORDERED ITEMS ARE SUBJECT TO MANUFACTURER APPROVAL PRIOR TO RETURN.
QUOTE IS SUBJECT TO EXPIRATION AS INDICATED IN THE ABOVE 05/06/2025 DATE.

The White Cap Family of Brands includes All-Tex Waterproofing Solutions, Harmac, Kenseal, Marvel Building & Masonry Supply, MASONPRO, and Williams Equipment & Supply. Learn more at About.WhiteCap.com.

Note: Due to volatility in the steel market from the recent Section 232 decision, domestic supply constraints and active trade negotiations, pricing is subject to change on a daily basis. Please review your pricing and contact your sales associate immediately to secure products and pricing.

WHITE CAP RESERVES THE RIGHT TO ADJUST PRICES TO REFLECT THE IMPACT OF ANY TARIFFS, DUTIES, OR SIMILAR GOVERNMENTAL CHARGES IMPOSED OR INCREASED AFTER THE DATE OF THIS QUOTE BUT PRIOR TO EXPIRATION.



84 Ridge Road, Montgomery, NY 12549 · 845-742-1710 · 845-231-6333 Fax

Hydrovacinc@aol.com

January 8, 2025

Verde Electric
Attention: Richie Dileonardo
89 Edison Ave
Mt. Vernon, NY

Via email: rdileonardo@verdeelectric.com

Subject: 2025 Hydrovac PW Rates

Dear Richie,

We agree to provide a hydro-trencher with 2-man crew as directed by your company. The large Hydrovac units we currently own are a 5400 CFM and 6400 CFM units (largest non-stationary units on the market today). They both have the capability to work down to depths of 60 feet deep and remote excavations up to 600 feet away from the truck. Low volume water 4-9 GPM, high pressure up to 6000-PSI cold water and 4500-PSI hot water. A spinner tip is always used on the end of our water lance to prevent a direct stream of water from damaging a utility that may be encountered while using high-pressure water.

Hydro excavator with 2-man crew - \$450.00 per hour onsite (7AM-3PM, Mon - Fri)

Hydrovac travel/mobilization - \$300/hour

Dump fee-\$300.00 per load if our dump site is utilized

Assumptions made developing this proposal:

- Certified prevailing wage is included and will be paid to HEI employees onsite
- Soil is conducive to vacuum excavation.
- No contaminated soil.
- Customer will provide Shoring for safe excavation

Thank you for allowing me to provide a proposal to you for this project. If you have any questions, please feel free to call me at (845) 742-1710

Hydrovac Excavating Inc.

A handwritten signature in black ink, appearing to read "Ira Conklin IV", is written over a horizontal line.

Ira Conklin IV

Accepted by:

Date & Title

Adjustments for CHEVY 2500 Pickup in undefined
GMC\CHEVY 2500
 On-Highway Light Duty Trucks

 Size Class:
300 hp & Over
 Weight:
N/A

Configuration for 2500

| | | | | | |
|--------------------|------------------|------------|--|----------|--|
| Axle Configuration | 4.0 x 2.0 | Cab Type | | Crew | |
| Horsepower | 360.0 hp | Power Mode | | Gasoline | |
| Ton Rating | 3.0 / 4.0 | | | | |

Blue Book Rates

** FHWA Rate is equal to the monthly ownership cost divided by 176 plus the hourly estimated operating cost.

| | Ownership Costs | | | | Estimated Operating Costs Hourly | FHWA Rate** Hourly |
|---------------------------------------|-----------------------|---------------------|---------------------|--------------------|-------------------------------------|-----------------------|
| | Monthly | Weekly | Daily | Hourly | | |
| Published Rates | USD \$2,690.00 | USD \$755.00 | USD \$190.00 | USD \$29.00 | USD \$12.68 | USD \$27.96 |
| Adjustments | | | | | | |
| Region (100%) | - | - | - | - | | |
| Model Year (2023: 99.97%) | (USD \$0.74) | (USD \$0.21) | (USD \$0.05) | (USD \$0.01) | | |
| Adjusted Hourly Ownership Cost (100%) | - | - | - | - | | |
| Hourly Operating Cost (100%) | | | | | - | |
| Total: | USD \$2,689.26 | USD \$754.79 | USD \$189.95 | USD \$28.99 | USD \$12.68 | USD \$27.96 |

Non-Active Use Rates

| | Hourly |
|--------------|-------------|
| Standby Rate | USD \$9.96 |
| Idling Rate | USD \$20.01 |

Rate Element Allocation

| Element | Percentage | Value |
|-----------------------------|------------|-----------------|
| Depreciation (ownership) | 26.94% | USD \$724.71/mo |
| Overhaul (ownership) | 34.81% | USD \$936.46/mo |
| CFC (ownership) | 16.12% | USD \$433.66/mo |
| Indirect (ownership) | 22.13% | USD \$595.17/mo |
| Fuel (operating) @ USD 3.13 | 37.3% | USD \$4.73/hr |

Revised Date: 2nd quarter 2025

These are the most accurate rates for the selected Revision Date(s). However, due to more frequent online updates, these rates may not match Rental Rate Blue Book® Print. Visit the Cost Recovery Product Guide on our Help page for more information.

The equipment represented in this report has been exclusively prepared for (rdileonardo@verdeelectric.com)

Adjustments for pc-78us-10 in undefined

May 8, 2025

Komatsu PC78US-10
 Crawler Mounted Hydraulic Excavators

Size Class:

6.5 - 8.4 mt

Weight:

N/A

Configuration for PC78US-10

| | | | |
|------------|----------------|------------------|--------------------|
| Horsepower | 65,5 hp | Operating Weight | 17747.0 lbs |
| Power Mode | Diesel | | |

Blue Book Rates

** FHWA Rate is equal to the monthly ownership cost divided by 176 plus the hourly estimated operating cost.

| | Ownership Costs | | | | Estimated Operating Costs Hourly | FHWA Rate** Hourly |
|---------------------------------------|-----------------------|-----------------------|---------------------|--------------------|-------------------------------------|-----------------------|
| | Monthly | Weekly | Daily | Hourly | | |
| Published Rates | USD \$6,320.00 | USD \$1,770.00 | USD \$445.00 | USD \$67.00 | USD \$17.44 | USD \$53.35 |
| Adjustments | | | | | | |
| Region (100%) | - | - | - | - | | |
| Model Year (2022: 99.94%) | (USD \$3.68) | (USD \$1.03) | (USD \$0.26) | (USD \$0.04) | | |
| Adjusted Hourly Ownership Cost (100%) | - | - | - | - | | |
| Hourly Operating Cost (100%) | | | | | - | |
| Total: | USD \$6,316.32 | USD \$1,768.97 | USD \$444.74 | USD \$66.96 | USD \$17.44 | USD \$53.33 |

Non-Active Use Rates

| | |
|--------------|---------------|
| | Hourly |
| Standby Rate | USD \$20.76 |
| Idling Rate | USD \$40.49 |

Rate Element Allocation

| Element | Percentage | Value |
|-----------------------------|------------|-------------------|
| Depreciation (ownership) | 31.33% | USD \$1,980.17/mo |
| Overhaul (ownership) | 42.15% | USD \$2,663.77/mo |
| CFC (ownership) | 16% | USD \$1,010.98/mo |
| Indirect (ownership) | 10.52% | USD \$665.08/mo |
| Fuel (operating) @ USD 3.70 | 26.38% | USD \$4.60/hr |

Revised Date: 2nd quarter 2025

These are the most accurate rates for the selected Revision Date(s). However, due to more frequent online updates, these rates may not match Rental Rate Blue Book® Print. Visit the Cost Recovery Product Guide on our Help page for more information.

The equipment represented in this report has been exclusively prepared for (rdleonardo@verdeelectric.com)

Adjustments for Trailer in undefined

May 8, 2025

Miscellaneous DROP 2 25
 Fixed Gooseneck Equipment Trailers

 Size Class:
 All
 Weight:
 10750 lbs

Configuration for DROP 2 25

| | | | |
|------------|---------------|-----------------|------------------|
| Capacity | 25.0 t | Deck Length | 16' - 18' |
| Deck Type | Drop | Number Of Axles | 2.0 |
| Power Mode | Manual | | |

Blue Book Rates

** FHWA Rate is equal to the monthly ownership cost divided by 176 plus the hourly estimated operating cost.

| | Ownership Costs | | | | Estimated Operating Costs Hourly | FHWA Rate** Hourly |
|---------------------------------------|-----------------------|---------------------|---------------------|--------------------|-------------------------------------|-----------------------|
| | Monthly | Weekly | Daily | Hourly | | |
| Published Rates | USD \$1,770.00 | USD \$495.00 | USD \$125.00 | USD \$19.00 | USD \$7.52 | USD \$17.58 |
| Adjustments | | | | | | |
| Region (New York: 105.7%) | USD \$100.89 | USD \$28.22 | USD \$7.13 | USD \$1.08 | | |
| Model Year (2022: 99.47%) | (USD \$9.87) | (USD \$2.76) | (USD \$0.70) | (USD \$0.11) | | |
| Adjusted Hourly Ownership Cost (100%) | - | - | - | - | | |
| Hourly Operating Cost (100%) | | | | | - | |
| Total: | USD \$1,861.02 | USD \$520.45 | USD \$131.43 | USD \$19.98 | USD \$7.52 | USD \$18.09 |

Non-Active Use Rates

| | Hourly |
|--------------|-------------|
| Standby Rate | USD \$6.87 |
| Idling Rate | USD \$10.57 |

Rate Element Allocation

| Element | Percentage | Value |
|--------------------------|------------|-----------------|
| Depreciation (ownership) | 42.48% | USD \$751.88/mo |
| Overhaul (ownership) | 35.02% | USD \$619.87/mo |
| CFC (ownership) | 10.13% | USD \$179.24/mo |
| Indirect (ownership) | 12.37% | USD \$219.00/mo |

Fuel cost data is not available for these rates.

Revised Date: 2nd quarter 2025

These are the most accurate rates for the selected Revision Date(s). However, due to more frequent online updates, these rates may not match Rental Rate Blue Book® Print. Visit the Cost Recovery Product Guide on our Help page for more information.

The equipment represented in this report has been exclusively prepared for (rdleonardo@verdeelectric.com)

Adjustments for Large Hammer Drill in undefined

May 9, 2025

Miscellaneous R 2
 Hammer Drills

 Size Class:
 All
 Weight:
 25 lbs

Configuration for R 2

| | | | |
|------|---------------|--------------|-----------------|
| Amps | 10.0 | Bit Capacity | 2.0 in |
| Bpm | 2100.0 | Power Mode | Electric |
| Type | Rotary | | |

Blue Book Rates

** FHWA Rate is equal to the monthly ownership cost divided by 176 plus the hourly estimated operating cost.

| | Ownership Costs | | | | Estimated Operating Costs Hourly | FHWA Rate** Hourly |
|---------------------------------------|---------------------|--------------------|-------------------|-------------------|-------------------------------------|-----------------------|
| | Monthly | Weekly | Daily | Hourly | | |
| Published Rates | USD \$145.00 | USD \$41.00 | USD \$10.00 | USD \$2.00 | USD \$0.97 | USD \$1.79 |
| Adjustments | | | | | | |
| Region (100%) | - | - | - | - | | |
| Model Year (2020: 99.01%) | (USD \$1.43) | (USD \$0.41) | (USD \$0.10) | (USD \$0.02) | | |
| Adjusted Hourly Ownership Cost (100%) | - | - | - | - | | |
| Hourly Operating Cost (100%) | | | | | - | |
| Total: | USD \$143.57 | USD \$40.59 | USD \$9.90 | USD \$1.98 | USD \$0.97 | USD \$1.79 |

Non-Active Use Rates

| | Hourly |
|--------------|------------|
| Standby Rate | USD \$0.20 |
| Idling Rate | USD \$0.82 |

Rate Element Allocation

| Element | Percentage | Value |
|--------------------------|------------|-----------------|
| Depreciation (ownership) | 14.25% | USD \$20.66/mo |
| Overhaul (ownership) | 75.03% | USD \$108.80/mo |
| CFC (ownership) | 4.88% | USD \$7.08/mo |
| Indirect (ownership) | 5.83% | USD \$8.46/mo |

Fuel cost data is not available for these rates.

Revised Date: 2nd quarter 2025

These are the most accurate rates for the selected Revision Date(s). However, due to more frequent online updates, these rates may not match Rental Rate Blue Book® Print. Visit the Cost Recovery Product Guide on our Help page for more information.

The equipment represented in this report has been exclusively prepared for (rdileonardo@verdeelectric.com)

Adjustments for Box Truck 176 in undefined
Miscellaneous 6X6 70KGVW DSL
 On-Highway Truck Tractors

 Size Class:
60,001 lbs & Over
 Weight:
 N/A

Configuration for 6X6 70KGVW DSL

| | | | |
|------------------------------|--------------------|------------|-----------------|
| Axle Configuration | 6X6 | Horsepower | 450.0 hp |
| Maximum Gross Vehicle Weight | 70000.0 lbs | Power Mode | Diesel |

Blue Book Rates

** FHWA Rate is equal to the monthly ownership cost divided by 176 plus the hourly estimated operating cost.

| | Ownership Costs | | | | Estimated Operating Costs Hourly USD \$59.76 | FHWA Rate** Hourly USD \$85.13 |
|---------------------------------------|-----------------------|-----------------------|---------------------|--------------------|--|--------------------------------------|
| | Monthly | Weekly | Daily | Hourly | | |
| Published Rates | USD \$4,465.00 | USD \$1,250.00 | USD \$315.00 | USD \$47.00 | | |
| Adjustments | | | | | | |
| Region (New York: 105.5%) | USD \$245.57 | USD \$68.75 | USD \$17.33 | USD \$2.59 | | |
| Model Year (2023: 99.95%) | (USD \$2.55) | (USD \$0.71) | (USD \$0.18) | (USD \$0.03) | | |
| Adjusted Hourly Ownership Cost (100%) | - | - | - | - | | |
| Hourly Operating Cost (100%) | | | | | - | |
| Total: | USD \$4,708.02 | USD \$1,318.04 | USD \$332.14 | USD \$49.56 | USD \$59.76 | USD \$86.51 |

Non-Active Use Rates

| | Hourly |
|--------------|-------------|
| Standby Rate | USD \$16.76 |
| Idling Rate | USD \$67.51 |

Rate Element Allocation

| Element | Percentage | Value |
|-----------------------------|------------|-------------------|
| Depreciation (ownership) | 42.23% | USD \$1,885.65/mo |
| Overhaul (ownership) | 37.34% | USD \$1,667.01/mo |
| CFC (ownership) | 9.35% | USD \$417.65/mo |
| Indirect (ownership) | 11.08% | USD \$494.69/mo |
| Fuel (operating) @ USD 3.70 | 68.21% | USD \$40.76/hr |

Revised Date: 2nd quarter 2025

These are the most accurate rates for the selected Revision Date(s). However, due to more frequent online updates, these rates may not match Rental Rate Blue Book® Print. Visit the Cost Recovery Product Guide on our Help page for more information.

The equipment represented in this report has been exclusively prepared for (rdileonardo@verdeelectric.com)

Adjustments for 10 Wheel Dump in undefined
Miscellaneous 8X4 18YD 85KGVW
 On-Highway Rear Dumps

 Size Class:
60,001 lbs & Over
 Weight:
21021 lbs

Configuration for 8X4 18YD 85KGVW

| | | | |
|------------------------------|--------------------------|------------|-----------------|
| Axle Configuration | 8X4 | Horsepower | 450.0 hp |
| Maximum Gross Vehicle Weight | 85000.0 lbs | Power Mode | Diesel |
| Struck Capacity | 15.0 - 18.0 cu yd | | |

Blue Book Rates

** FHWA Rate is equal to the monthly ownership cost divided by 176 plus the hourly estimated operating cost.

| | Ownership Costs | | | | Estimated Operating Costs Hourly | FHWA Rate** Hourly |
|---------------------------------------|-----------------------|-----------------------|---------------------|--------------------|-------------------------------------|-----------------------|
| | Monthly | Weekly | Daily | Hourly | | |
| Published Rates | USD \$5,810.00 | USD \$1,625.00 | USD \$405.00 | USD \$61.00 | USD \$68.77 | USD \$101.78 |
| Adjustments | | | | | | |
| Region (100%) | - | - | - | - | | |
| Model Year (2023: 99.97%) | (USD \$1.60) | (USD \$0.45) | (USD \$0.11) | (USD \$0.02) | | |
| Adjusted Hourly Ownership Cost (100%) | - | - | - | - | | |
| Hourly Operating Cost (100%) | | | | | - | |
| Total: | USD \$5,808.40 | USD \$1,624.55 | USD \$404.89 | USD \$60.98 | USD \$68.77 | USD \$101.77 |

Non-Active Use Rates

| | Hourly |
|--------------|-------------|
| Standby Rate | USD \$22.47 |
| Idling Rate | USD \$79.58 |

Rate Element Allocation

| Element | Percentage | Value |
|-----------------------------|------------|-------------------|
| Depreciation (ownership) | 47.77% | USD \$2,775.28/mo |
| Overhaul (ownership) | 31.93% | USD \$1,855.03/mo |
| CFC (ownership) | 9.76% | USD \$567.15/mo |
| Indirect (ownership) | 10.54% | USD \$612.55/mo |
| Fuel (operating) @ USD 3.70 | 67.73% | USD \$46.58/hr |

Revised Date: 2nd quarter 2025

These are the most accurate rates for the selected Revision Date(s). However, due to more frequent online updates, these rates may not match Rental Rate Blue Book® Print. Visit the Cost Recovery Product Guide on our Help page for more information.

The equipment represented in this report has been exclusively prepared for (rdileonardo@verdeelectric.com)

Adjustments for Penn Compressor in undefined

May 8, 2025

Miscellaneous 100D
Portable Rotary Sliding Vane Air Compressors

Size Class:
To 124 cu ft/min
Weight:
2350 lbs



Configuration for 100D

Power Mode Diesel Horsepower 60.0 hp

Blue Book Rates

** FHWA Rate is equal to the monthly ownership cost divided by 176 plus the hourly estimated operating cost.

| | Ownership Costs | | | | Estimated Operating Costs Hourly | FHWA Rate** Hourly |
|---------------------------------------|---------------------|---------------------|--------------------|-------------------|-------------------------------------|-----------------------|
| | Monthly | Weekly | Daily | Hourly | | |
| Published Rates | USD \$515.00 | USD \$145.00 | USD \$36.00 | USD \$5.00 | USD \$11.10 | USD \$14.03 |
| Adjustments | | | | | | |
| Region (100%) | - | - | - | - | | |
| Model Year (2024: 99.94%) | (USD \$0.29) | (USD \$0.08) | (USD \$0.02) | (USD \$0.00) | | |
| Adjusted Hourly Ownership Cost (100%) | - | - | - | - | | |
| Hourly Operating Cost (100%) | | | | | - | |
| Total: | USD \$514.71 | USD \$144.92 | USD \$35.98 | USD \$5.00 | USD \$11.10 | USD \$14.02 |

Non-Active Use Rates

| | Hourly |
|--------------|-------------|
| Standby Rate | USD \$1.07 |
| Idling Rate | USD \$11.35 |

Rate Element Allocation

| Element | Percentage | Value |
|-----------------------------|------------|-----------------|
| Depreciation (ownership) | 23.97% | USD \$123.45/mo |
| Overhaul (ownership) | 63.25% | USD \$325.72/mo |
| CFC (ownership) | 7.02% | USD \$36.13/mo |
| Indirect (ownership) | 5.77% | USD \$29.70/mo |
| Fuel (operating) @ USD 3.70 | 75.95% | USD \$8.43/hr |

Revised Date: 2nd quarter 2025

These are the most accurate rates for the selected Revision Date(s). However, due to more frequent online updates, these rates may not match Rental Rate Blue Book® Print. Visit the Cost Recovery Product Guide on our Help page for more information.

The equipment represented in this report has been exclusively prepared for (rdileonardo@verdeelectric.com)



Insurance | Risk Management | Consulting

30 Century Hill Drive, Suite 200 M - 518.869.3535
 Latham, NY 12110 F - 518.869.3580
 United States T - 888.869.3535
 ajg.com

October 31, 2024

New York State Department of Transportation
 50 Wolf Road
 Albany, NY 12232

Re: Insured – Verde Electric Corp – 89 Edison Avenue, Mount Vernon, NY 10550

General Liability / Umbrella Insurance Rate Calculation Based on Sales:

| | | |
|---|-----------------|-----------------------|
| General Liability (per \$100 of payroll) | \$ 28.12 | See below for support |
| Lead Umbrella ((per \$100 of payroll) | \$ 3.41 | See below for support |
| First Umbrella ((per \$100 of payroll) | \$ 2.47 | See below for support |
| Second Umbrella (per \$100 of payroll) | \$ 2.16 | See below for support |
| Total | \$ 15.12 | |
| Per \$100 of Payroll | \$100 | |
| Verde Electric G/L & Umbrella Rate | 36.16% | |

General Liability

Insuring Company: Traveler Indemnity Company.

A M. Best Rating: A++XV (Admitted)

Policy Number: VTC2KCO3X459385IND23

Policy Expires: 10/31/2025

Limit of Liability:

General Aggregate: \$4,000,000

Products Completed Operations Aggregate: \$4,000,000

Personal & Advertising Injury: \$2,000 ,000

Each Occurrence: \$2,000,000

Damage to Rented Premise: \$300,000

Rate- \$28.12 per \$100 of Payroll



30 Century Hill Drive, Suite 200 M - 518.869.3535
Latham, NY 12110 F - 518.869.3580
United States T - 888.869.3535
ajg.com

Insuring Company: Starr Indemnity & Liability Company

A M. Best Rating: A XV (Admitted)

Policy Number: 1100588039231

Policy Expires: 10/31/2025

Limit of Liability:

General Aggregate: \$3,000,000

Each Occurrence: \$3,000,000

Rate- \$3.41 per \$100 of Payroll

Excess Umbrella Second

Insuring Company: Berkley Casualty Company

A M. Best Rating: A+ XV (Admitted)

Policy Number: BCS880013420

Policy Expires: 10/31/2025

Limit of Liability:

General Aggregate: \$7,000,000

Each Occurrence: \$7,000,000

Rate- \$2.47 per \$100 of Payroll

Excess Umbrella Third

Insuring Company: Zurich American Insurance Company & Liberty Insurance Underwriting

A M. Best Rating: A+ XV (Admitted) and A XV (Admitted)

Policy Number: AEC 7130570-01 and 100057021602

Policy Expires: 10/31/2025

Limit of Liability:

General Aggregate: \$10,000,000

Each Occurrence: \$10,000,000

Rate- \$2.16 per \$100 of Payroll



30 Century Hill Drive, Suite 200 M - 518.869.3535
 Latham, NY 12110 F - 518.869.3580
 United States T - 888.869.3535
 ajg.com

Insuring Company: Charter Oak Fire Insurance Company (Travelers)

A M. Best Rating: A++XV

Policy Number: UB4X4902572325H

Policy Expires: 10/30/2025

Limit of Liability:

Each Accident: Statutory Disease

Policy Limit: Statutory

Disease: Each Employee: Statutory

Exposure: Electrical Wiring Rate - \$10.06 per \$100 of Payroll; Conduit Rate - \$13.61 per \$100

Average Rate - \$12.00 Per \$100 of Payroll (See Support below)

| | Estimated Payroll | Rate per \$100 | Premium | |
|-------------------|-----------------------|----------------|---------------------|--------------|
| Electrical Wiring | \$1,100,000.00 | 10.06% | \$110,673.86 | |
| Conduit | \$1,300,000.00 | 13.61% | \$177,069.36 | |
| Total | \$2,400,000.00 | | \$287,743.22 | |
| | | | 12.00% | Blended Rate |

If you would like to speak with me directly please feel free to contact me. My email address is David_Brockmann@ajg.com; my office phone number is 518-533-6898 and my mobile phone number is 518-330-1743.

David Brockmann, Jr.
 Area Vice President
 Director of Construction Services
 Arthur J. Gallagher Risk Management Services



Insurance | Risk Management | Consulting

30 Century Hill Drive, Suite 200
Latham, NY 12110
USA o

518-869-3535
www.ajg.com

September 9, 2025

Verde Electric Maintenance Corporation.
89 Edison Avenue
Mount Vernon, NY 10550

**Re: Workers Compensation Experience Modifications
Verde Electric Maintenance Corporation.**

Dear Tricia:

Please allow this letter to acknowledge and confirm the Workers Compensation Experience Modification for the above.

The EMR's are as follows:

| <u>Effective Year</u> | <u>Experience Modification</u> |
|-----------------------|--------------------------------|
| 10/30/24 to 10/30/25 | 1.00 |

We trust you will find the enclosed in order but should you have any questions please contact our office.

Sincerely,

Julie Kaiser

Julie Kaiser
Client Service Manager

Reset Form

NEW YORK STATE DEPARTMENT OF TRANSPORTATION

Print Form

COST ANALYSIS WORKSHEET (9/22)

Contract D# 036472

Change Order # 001

Field Change Payment #

CO Item Qty 13

Section 1 - Existing Contract Item

Use the Item Analysis Report and CONR 22 Composite Report in BI to fill out the below information. Follow Added Work Cost Analysis Decision Flow Chart.

Item Spec No

Unit Bid Price

Bid Qty

Current Contract Qty

Major Item

Minor Item

75% Threshold

Renegotiation Threshold

125% Threshold

(200% and \$5,000 over original contract amount)

High Bid Item (over 125%) Yes No

Section 2 - New Contract Item or Continuation of Existing Item

New Item Spec No 206.05A

Renegotiated Qty 13

Contractor Quoted Unit Price \$8,416.08

Method Chosen:

- Original Bid Price Acceptable?
Contractor agrees to work at the Original Contract Bid Price adjusted for documented changes in material costs, equipment rates, mobilization, and/or site conditions, and bid price is reasonable compensation for the quantity of added work: include letter from contractor, and supporting documentation for adjustments (need price analysis) on CO Header
Weighted Average Price (WAP) Comparison (must have at least 3 contracts)

Pay Item Catalog Date Range to

PIC Qty Range to N/A

Regional WAP Statewide WAP

Printout of PIC w/ Qty Range, dates, prices attached?

- Comparison to Average of 3 Lowest Bidders (on contract, not item)

Average Price \$0.00 Bidder 1

Bidder 2

Bidder 3

Printout of 3 Lowest Bidders on the Contract attached?

- Price Analysis

MURK 26/27 Price Analysis Worksheet attached and all documentation attached?

- Force Account Work (FAW)

FE (Force Estimate) Estimate of Labor, Materials, and Equipment work up included?

FAW (Final) Included with all MURK forms and documentation attached?

Project Conditions/Variance Explanation attached?

Signature Kelly A. Vito

Date Jan 30, 2026



89 Edison Avenue • Mt. Vernon, New York 10550
Phone 914-664-7000 • Facsimile 914-668-7997

February 20, 2026

WSP Field Office/Broadway TSP
1 Corwin Court, Room 102
Newburgh, NY 10550
Attn: Arlisa McGrath, EIC

RE: Contract Pins 8005.26 and 8758.75
Broadway Pedestrian and Traffic Signal Improvements
VEMC Job #8510 and 8530
Item No. 680.80324603 – Microcomputer Traffic Control Cabinet Base (Painted)
Letter of Concurrence

Dear Arlisa:

Verde Electric Maintenance Corp. accepts the agreed price for:

| | |
|-------------------|--|
| Item No.: | 680.80324603 |
| Item Description: | Microcomputer Traffic Control Cabinet Base (Painted) |
| Quantity: | 6 ea |
| Unit Price: | \$2,890.33 |
| Total Extension: | \$17,341.98 |

Please do not hesitate to contact me if you have any questions.

Very truly yours,
Verde Electric Maintenance Corp.

Robert Craig
Vice President

NEW YORK STATE DEPARTMENT OF TRANSPORTATION

Agreed Price Worksheet - Prime Contractor

Contract: 8758.75 Item No.: 680.80324603 Quantity: 6.00 Units: EA

Item Description : Microcomputer traffic control cabinet base (painted)

(A) LABOR

| Trade | Reg Hours | Wage Rate | Cost | Fringe Hours | Fringe Rate | Cost |
|---------------------------|--------------|-----------------|--------------------|--------------|-----------------|--------------------|
| <u>Working Foreamn</u> | <u>18.00</u> | <u>\$ 64.34</u> | <u>\$ 1,158.12</u> | <u>18.00</u> | <u>\$ 42.53</u> | <u>\$ 765.54</u> |
| <u>Journeyman Lineman</u> | <u>36.00</u> | <u>\$ 58.49</u> | <u>\$ 2,105.64</u> | <u>36.00</u> | <u>\$ 41.68</u> | <u>\$ 1,500.48</u> |
| | | | | | | |
| | | | | | | |
| | | | | | | |
| | | | | | | |
| | | | | | | |
| | | | | | | |
| | | | | | | |

Wages \$ 3,263.76 Fringes \$ 2,266.02

If Fringes are paid directly to employee via cash or check, Enter value here:

\$ 0.00

Worker's Compensation Rate (%):

12.00 %

| | |
|-----------------------------|---------------------------|
| Total of Wages and Fringes: | <u>\$ 5,529.78</u> |
| Workers Compensation: | <u>\$ 391.65</u> |
| Standard Labor Markup: | <u>\$ 407.97</u> |
| Fringe Benefit Markup: | <u>\$ 0.00</u> |
| Labor Total: | <u>\$ 6,329.40</u> |

(The Contractor shall submit an insurance policy declaration / rate page from its insurer to validate the Workers Comp insurance rate based on an EMR of 1.0.)

(B) MATERIALS

| Description | Units | # of Units | Cost/Unit | Cost | Description | Units | # of Units | Cost/Unit | Cost |
|---------------------------|-----------|--------------|-----------------|-------------------|-------------|-------|------------|-----------|------|
| <u>Painted trap base</u> | <u>ea</u> | <u>6.00</u> | <u>\$825.50</u> | <u>\$4,953.00</u> | | | | | |
| <u>3/8"x5-1/8" anchor</u> | <u>ea</u> | <u>24.00</u> | <u>\$5.30</u> | <u>\$127.20</u> | | | | | |
| | | | | | | | | | |
| | | | | | | | | | |

Materials Total: \$5,080.20

(C) EQUIPMENT

| Description | Hours | FHWA Rate | Cost | Description | Hours | FHWA Rate | Cost |
|---------------------|--------------|----------------|-------------------|-------------|-------|-----------|------|
| <u>Pickup Truck</u> | <u>18.00</u> | <u>\$28.55</u> | <u>\$513.90</u> | | | | |
| <u>Box Truck</u> | <u>18.00</u> | <u>\$83.17</u> | <u>\$1,497.06</u> | | | | |
| <u>generator</u> | <u>18.00</u> | <u>\$5.91</u> | <u>\$106.38</u> | | | | |
| | | | | | | | |

Equipment Total: \$ 2,117.34

(D) SERVICES

| Description / Type | # of Units | Cost / Unit | Cost | Description / Type | # of Units | Cost / Unit | Cost |
|--------------------|------------|-------------|------|--------------------|------------|-------------|------|
| | | | | | | | |
| | | | | | | | |

Services Total:

(E) OVERHEAD & PROFIT

| | OH & Profit % | Cost |
|--------------------------------------|---------------|--------------------|
| Labor, Materials, & Equipment Total: | <u>20.00</u> | <u>\$ 2,705.39</u> |
| Services: | <u>20.00</u> | <u>\$ 0.00</u> |

Overhead & Profit Total: \$ 2,705.39

(F) INSURANCE

Enter rate here if based on payroll

Payroll Based Cost Basis

Enter rate here if based on sales

Sales Based Cost Basis

34.00 %

\$ 3,263.76

\$ 0.00

Insurance Total: \$ 1,109.68

Item Total: \$ 17,342.01

Unit Price: \$ 2,890.33 per EA

\$ 17,341.98

Robert Craig
Contractor's Rep Name

Robert Craig
Signature

2-17-26
Date

Alwa for Staff
Engineer-in-Charge's Name

2/19/26
Signature

Date

ESTIMATE

Nova Tech, LLC
480 Forest Ave
Ste LL100 Ste LL100
Locust Valley, NY 11560-2151

Jessica@NovaTechLLCNY.com
+1 (631) 365-9785



Bill to
Verde Electric
89 Edison Avenue
Mount Vernon, New York 10550

Ship to
Verde Electric
89 Edison Avenue
Mount Vernon, New York 10550

Estimate details

Estimate no.: 1139
Estimate date: 09/15/2025

| Product or service | Description | Qty | Rate | Amount |
|--------------------|---|-----|----------|-----------------|
| 680.80324603 | Microcomputer Traffic Signal Cabinet Base | 1 | \$825.50 | \$825.50 |
| Total | | | | \$825.50 |

Note to customer
Standard freight included.

Accepted date

Accepted by



Customer Service
 T 1-800-879-8000
 F 1-800-879-7000
 www.hilti.com

Bill-To Address

VERDE ELECTRIC CORP
 89 EDISON AVE
 MOUNT VERNON NY 10550-5003

Quotation 933032017

Page 1(1)

| | | | |
|-----------------------|--------------------|--------------------------------|-------------------|
| Order Type: | Quotation | Customer Number: | 10828314 |
| Creation Date: | 09/12/2025 | Purchase Order No.: | QUOTE |
| Our Contact: | Christopher Kologe | Your Reference: | |
| | | Your Main Contact: | Mr. George Caruso |
| | | Your Main Contact Tel.: | 09146647000 |

Delivery Address VERDE ELECTRIC CORP, 89 EDISON AVE, MOUNT VERNON NY 10550-5003,

| Item No. | Description | Ordered Quantity | Net Price/Unit | Net Value |
|----------|--|------------------------|---------------------------|---------------|
| | | | \$105.96/20 = \$5.30 Each | |
| 2197986 | Anchor rod HAS-E-55 3/8"x5-1/8" | 1 ZPX of 20 EA = 20 EA | 105.96 ZPX | 105.96 |
| 2334276 | Injectable mortar HY 200-R V3 330/1/WH | 1 EA | 29.53 EA | 29.53 |
| | | | Items Total | 135.49 |
| | | | Freight | 31.00 |
| | | | Total net value | 166.49 |
| | | | Sales Tax | 13.94 |
| | | | Final Total USD | 180.43 |

Price subject to change without notice.

All transactions governed by Hilti's Terms and Conditions found at Hilti.com. Acceptance is limited to the express terms contained herein. Any purchase order issued by Customer after acceptance of this offer, even if signed by Hilti, shall be treated solely as authorization to proceed with the order under the accepted terms and such purchase order will not amend or vary the accepted terms.

Customer Signature: _____ Date: _____

Hilti, Inc
 Operations Center
 6400 S 122nd E Ave
 Tulsa, OK 74146

Adjustments for Pickup 171 in All Saved Models

Ford SUPER DUTY F-350 XL 4X4 GAS
Light Duty Trucks



Size Class:
2
Weight:
N/A

Configuration for SUPER DUTY F-350 XL 4X4 GAS

Power Mode Gasoline Wheelbase 142 Inches
Model Trim XL Gross Vehicle Weight Rating 10000 Pounds

Blue Book Rates

** FHWA Rate is equal to the monthly ownership cost divided by 176 plus the hourly estimated operating cost.

| | Ownership Costs | | | | Estimated Operating Costs Hourly USD \$12.04 | FHWA Rate** Hourly USD \$28.55 |
|---------------------------------------|-----------------------|---------------------|---------------------|--------------------|--|--------------------------------------|
| | Monthly | Weekly | Daily | Hourly | | |
| Published Rates | USD \$2,905.00 | USD \$815.00 | USD \$205.00 | USD \$31.00 | | |
| Adjustments | | | | | | |
| Region (100%) | - | - | - | - | | |
| Model Year (2023: 98.54%) | (USD \$42.38) | (USD \$11.89) | (USD \$2.99) | (USD \$0.45) | | |
| Adjusted Hourly Ownership Cost (100%) | - | - | - | - | | |
| Hourly Operating Cost (100%) | | | | | USD \$12.04 | USD \$28.30 |
| Total: | USD \$2,862.62 | USD \$803.11 | USD \$202.01 | USD \$30.55 | | |

Non-Active Use Rates

| | Hourly |
|--------------|-------------|
| Standby Rate | USD \$9.83 |
| Idling Rate | USD \$20.02 |

Rate Element Allocation

| Element | Percentage | Value |
|-----------------------------|------------|-------------------|
| Depreciation (ownership) | 27.46% | USD \$797.68/mo |
| Overhaul (ownership) | 39.54% | USD \$1,148.54/mo |
| CFC (ownership) | 16.42% | USD \$476.88/mo |
| Indirect (ownership) | 16.59% | USD \$481.90/mo |
| Fuel (operating) @ USD 3.17 | 31.23% | USD \$3.76/hr |

Revised Date: 3rd quarter 2025

These are the most accurate rates for the selected Revision Date(s). However, due to more frequent online updates, these rates may not match Rental Rate Blue Book® Print. Visit the Cost Recovery Product Guide on our Help page for more information.

The equipment represented in this report has been exclusively prepared for (rdileonardo@verdeelectric.com)

Adjustments for 6000 Watt Generator in All Saved Models

Miscellaneous GAS 6,000 W
Small Generator Sets

Size Class:
5,001 - 10,000 W
Weight:
N/A



Configuration for GAS 6,000 W

Horsepower **13.0 hp** Power Mode **Gasoline**
Prime Output **6000.0 W**

Blue Book Rates

** FHWA Rate is equal to the monthly ownership cost divided by 176 plus the hourly estimated operating cost.

| | Ownership Costs | | | | Estimated Operating Costs Hourly USD \$5.06 | FHWA Rate** Hourly USD \$5.91 |
|---------------------------------------|---------------------|--------------------|--------------------|-------------------|---|-------------------------------------|
| | Monthly | Weekly | Daily | Hourly | | |
| Published Rates | USD \$150.00 | USD \$42.00 | USD \$11.00 | USD \$2.00 | | |
| Adjustments | | | | | | |
| Region (100%) | - | - | - | - | | |
| Model Year (2023: 99.91%) | (USD \$0.14) | (USD \$0.04) | (USD \$0.01) | (USD \$0.00) | | |
| Adjusted Hourly Ownership Cost (100%) | - | - | - | - | | |
| Hourly Operating Cost (100%) | | | | | USD \$5.06 | USD \$5.91 |
| Total: | USD \$149.86 | USD \$41.96 | USD \$10.99 | USD \$2.00 | | |

Non-Active Use Rates

Standby Rate **Hourly USD \$0.58**
Idling Rate **Hourly USD \$4.40**

Rate Element Allocation

| Element | Percentage | Value |
|-----------------------------|------------|----------------|
| Depreciation (ownership) | 42.74% | USD \$64.10/mo |
| Overhaul (ownership) | 31.77% | USD \$47.65/mo |
| CFC (ownership) | 11.76% | USD \$17.64/mo |
| Indirect (ownership) | 13.74% | USD \$20.61/mo |
| Fuel (operating) @ USD 3.17 | 70.16% | USD \$3.55/hr |

Revised Date: 3rd quarter 2025

These are the most accurate rates for the selected Revision Date(s). However, due to more frequent online updates, these rates may not match Rental Rate Blue Book®. Print. Visit the Cost Recovery Product Guide on our Help page for more information.

The equipment represented in this report has been exclusively prepared for (rdileonardo@verdeelectric.com)

Adjustments for Box Truck 176 in All Saved Models
Miscellaneous 6X6 70KGVW DSL
 On-Highway Truck Tractors

 Size Class:
 60,001 lbs & Over
 Weight:
 N/A

Configuration for 6X6 70KGVW DSL

| | | | |
|------------------------------|--------------------|------------|-----------------|
| Axle Configuration | 6X6 | Horsepower | 450.0 hp |
| Maximum Gross Vehicle Weight | 70000.0 lbs | Power Mode | Diesel |

Blue Book Rates

** FHWA Rate is equal to the monthly ownership cost divided by 176 plus the hourly estimated operating cost.

| | Ownership Costs | | | | Estimated Operating Costs Hourly USD \$57.80 | FHWA Rate** Hourly USD \$83.17 |
|---------------------------------------|-----------------------|-----------------------|---------------------|--------------------|--|--------------------------------------|
| | Monthly | Weekly | Daily | Hourly | | |
| Published Rates | USD \$4,465.00 | USD \$1,250.00 | USD \$315.00 | USD \$47.00 | | |
| Adjustments | | | | | | |
| Region (New York: 104%) | USD \$178.60 | USD \$50.00 | USD \$12.60 | USD \$1.88 | | |
| Model Year (2023: 99.94%) | (USD \$2.57) | (USD \$0.72) | (USD \$0.18) | (USD \$0.03) | | |
| Adjusted Hourly Ownership Cost (100%) | - | - | - | - | | |
| Hourly Operating Cost (100%) | | | | | USD \$57.80 | USD \$84.17 |
| Total: | USD \$4,641.02 | USD \$1,299.28 | USD \$327.42 | USD \$48.85 | | |

Non-Active Use Rates

| | |
|--------------|---------------|
| | Hourly |
| Standby Rate | USD \$16.51 |
| Idling Rate | USD \$65.35 |

Rate Element Allocation

| Element | Percentage | Value |
|-----------------------------|------------|-------------------|
| Depreciation (ownership) | 42.23% | USD \$1,885.65/mo |
| Overhaul (ownership) | 37.39% | USD \$1,669.45/mo |
| CFC (ownership) | 9.35% | USD \$417.65/mo |
| Indirect (ownership) | 11.02% | USD \$492.25/mo |
| Fuel (operating) @ USD 3.54 | 67.44% | USD \$38.98/hr |

Revised Date: 3rd quarter 2025

These are the most accurate rates for the selected Revision Date(s). However, due to more frequent online updates, these rates may not match Rental Rate Blue Book® Print. Visit the Cost Recovery Product Guide on our Help page for more information.

The equipment represented in this report has been exclusively prepared for (rdileonardo@verdeelectric.com)

VERDE ELECTRIC CORP LABOR RATE BREAKDOWN

EFFECTIVE DATES:

FROM: 5/5/2025
TO: 5/3/2026

TRADE CLASSIFICATION: WORKING FOREMAN

UNION: NORTHEAST LINE CONST.
LOCAL NO: 1249

| | | Straight Time | Overtime & Saturday | Sunday |
|---|-----------------------------------|-----------------|------------------------|------------------|
| 1 HOURLY RATE | | \$ 64.34 | \$ 96.51 | \$ 128.68 |
| 2 FRINGES: | | RATE | | |
| | NEBF | 3.00% | \$ 1.93 | \$ 2.90 |
| | Insurance Fund | \$10.40 | \$ 10.40 | \$ 10.40 |
| | Pension Fund | \$14.50 | \$ 14.50 | \$ 14.50 |
| | Annuity Fund | \$7.00 | \$ 7.00 | \$ 7.00 |
| | Safety Training Fund | 3.25% | \$ 2.09 | \$ 3.14 |
| | NEAT | 0.75% | \$ 0.48 | \$ 0.72 |
| | NEIF | 0.50% | \$ 0.32 | \$ 0.48 |
| | NELCAF | 0.75% | \$ 0.48 | \$ 0.72 |
| | NLMCC | \$0.01 | \$ 0.01 | \$ 0.01 |
| ** | Holiday | \$5.31 | \$ 5.31 | \$ 5.31 |
| TOTAL FRINGES: | | \$ 42.53 | \$ 45.18 | \$ 47.84 |
| 3 PAYROLL TAXES & INSURANCE | | RATE | | |
| | FICA (Social Security & Medicare) | 7.65% | \$ 4.92 | \$ 7.38 |
| | Federal Unemployment | 0.60% | \$ 0.39 | \$ 0.58 |
| | Metro Tax | 0.34% | \$ 0.22 | \$ 0.33 |
| | New York Unemployment | 8.33% | \$ 5.36 | \$ 8.04 |
| | Workers Comp | 7.80% | \$ 5.02 | \$ 5.02 |
| | General Liability | 15.50% | \$ 9.97 | \$ 14.96 |
| TOTAL PAYROLL TAXES & INSURANCE: | | | \$ 25.88 | \$ 36.31 |
| 4 TOTAL LABOR RATE, FRINGES, TAXES & INSURANCE | | | \$ 132.75 | \$ 178.00 |
| | | | \$ 223.25 | |

* Benefits payable up to a maximum 40 hour week
 ** Holiday computed as 80 hour cost divided by 1,920 (est. 48 week work year)

VERDE ELECTRIC CORP LABOR RATE BREAKDOWN

EFFECTIVE DATES:

FROM: 5/5/2025
TO: 5/3/2026

TRADE CLASSIFICATION:

JOURNEYMAN LINEMAN/TECHNICIAN

UNION: NORTHEAST LINE CONST.
LOCAL NO: 1249

| | | Straight Time | Overtime & Saturday | Sunday |
|---|-----------------------------------|---------------|---------------------|-----------|
| 1 HOURLY RATE | | \$ 58.49 | \$ 87.74 | \$ 116.98 |
| 2 FRINGES: | | RATE | | |
| | NEBF | 3.00% | \$ 1.75 | \$ 2.63 |
| | Insurance Fund | \$10.40 | \$ 10.40 | \$ 10.40 |
| | Pension Fund | \$14.50 | \$ 14.50 | \$ 14.50 |
| | Annuity Fund | \$7.00 | \$ 7.00 | \$ 7.00 |
| | Safety Training Fund | 3.25% | \$ 1.90 | \$ 2.85 |
| | NEAT | 0.75% | \$ 0.44 | \$ 0.66 |
| | NEIF | 0.50% | \$ 0.29 | \$ 0.44 |
| | NELCAF | 0.75% | \$ 0.44 | \$ 0.66 |
| | NLMCC | \$0.01 | \$ 0.01 | \$ 0.01 |
| ** | Holiday | \$4.95 | \$ 4.95 | \$ 4.95 |
| TOTAL FRINGES: | | | \$ 41.68 | \$ 44.10 |
| 3 PAYROLL TAXES & INSURANCE | | RATE | | |
| | FICA (Social Security & Medicare) | 7.65% | \$ 4.47 | \$ 6.71 |
| | Federal Unemployment | 0.60% | \$ 0.35 | \$ 0.53 |
| | Metro Tax | 0.34% | \$ 0.20 | \$ 0.30 |
| | New York Unemployment | 8.33% | \$ 4.87 | \$ 7.31 |
| | Workers Comp | 7.80% | \$ 4.56 | \$ 4.56 |
| | General Liability | 15.50% | \$ 9.07 | \$ 13.60 |
| TOTAL PAYROLL TAXES & INSURANCE: | | | \$ 23.52 | \$ 33.01 |
| 4 TOTAL LABOR RATE, FRINGES, TAXES & INSURANCE | | | \$ 123.70 | \$ 164.84 |
| | | | \$ 205.98 | |

* Benefits payable up to a maximum 40 hour week
 ** Holiday computed as 80 hour cost divided by 1,920 (est. 48 week work year)



Insurance | Risk Management | Consulting

30 Century Hill Drive, Suite 200 M - 518.869.3535
 Latham, NY 12110 F - 518.869.3580
 United States T - 888.869.3535
 ajg.com

October 31, 2024

New York State Department of Transportation
 50 Wolf Road
 Albany, NY 12232

Re: Insured – Verde Electric Corp – 89 Edison Avenue, Mount Vernon, NY 10550

General Liability / Umbrella Insurance Rate Calculation Based on Sales:

| | | |
|--|-----------------|-----------------------|
| General Liability (per \$100 of payroll) | \$ 28.12 | See below for support |
| Lead Umbrella ((per \$100 of payroll) | \$ 3.41 | See below for support |
| First Umbrella ((per \$100 of payroll) | \$ 2.47 | See below for support |
| Second Umbrella (per \$100 of payroll) | \$ 2.16 | See below for support |
| Total | \$ 15.12 | |
| Per \$100 of Payroll | \$100 | |
| Verde Electric G/L & Umbrella Rate | 36.16% | |

General Liability

Insuring Company: Traveler Indemnity Company.

A M. Best Rating: A++XV (Admitted)

Policy Number: VTC2KCO3X459385IND23

Policy Expires: 10/31/2025

Limit of Liability:

General Aggregate: \$4,000,000

Products Completed Operations Aggregate: \$4,000,000

Personal & Advertising Injury: \$2,000,000

Each Occurrence: \$2,000,000

Damage to Rented Premise: \$300,000

Rate- \$28.12 per \$100 of Payroll

Insuring Company: Starr Indemnity & Liability Company

A M. Best Rating: A XV (Admitted)

Policy Number: 1100588039231

Policy Expires: 10/31/2025

Limit of Liability:

General Aggregate: \$3,000,000

Each Occurrence: \$3,000,000

Rate- \$3.41 per \$100 of Payroll

Excess Umbrella Second

Insuring Company: Berkley Casualty Company

A M. Best Rating: A+ XV (Admitted)

Policy Number: BCS880013420

Policy Expires: 10/31/2025

Limit of Liability:

General Aggregate: \$7,000,000

Each Occurrence: \$7,000,000

Rate- \$2.47 per \$100 of Payroll

Excess Umbrella Third

Insuring Company: Zurich American Insurance Company & Liberty Insurance Underwriting

A M. Best Rating: A+ XV (Admitted) and A XV (Admitted)

Policy Number: AEC 7130570-01 and 100057021602

Policy Expires: 10/31/2025

Limit of Liability:

General Aggregate: \$10,000,000

Each Occurrence: \$10,000,000

Rate- \$2.16 per \$100 of Payroll



Gallagher

Workers Compensation
Insurance | Risk Management | Consulting

30 Century Hill Drive, Suite 200 M - 518.869.3535
Latham, NY 12110 F - 518.869.3580
United States T - 888.869.3535
ajg.com

Insuring Company: Charter Oak Fire Insurance Company (Travelers)

A.M. Best Rating: A++XV

Policy Number: UB4X4902572325H

Policy Expires: 10/30/2025

Limit of Liability:

Each Accident: Statutory Disease

Policy Limit: Statutory

Disease: Each Employee: Statutory

Exposure: Electrical Wiring Rate - \$10.06 per \$100 of Payroll; Conduit Rate - \$13.61 per \$100

Average Rate - \$12.00 Per \$100 of Payroll (See Support below)

| | Estimated Payroll | Rate per \$100 | Premium | |
|-------------------|-----------------------|----------------|---------------------|--------------|
| Electrical Wiring | \$1,100,000.00 | 10.06% | \$110,673.86 | |
| Conduit | \$1,300,000.00 | 13.61% | \$177,069.36 | |
| Total | \$2,400,000.00 | | \$287,743.22 | |
| | | | 12.00% | Blended Rate |

If you would like to speak with me directly please feel free to contact me. My email address is David_Brockmann@ajg.com; my office phone number is 518-533-6898 and my mobile phone number is 518-330-1743.

David Brockmann, Jr.
Area Vice President
Director of Construction Services
Arthur J. Gallagher Risk Management Services



Insurance | Risk Management | Consulting

30 Century Hill Drive, Suite 200
Latham, NY 12110
USA o

518-869-3535
www.ajg.com

September 9, 2025

Verde Electric Maintenance Corporation.
89 Edison Avenue
Mount Vernon, NY 10550

**Re: Workers Compensation Experience Modifications
Verde Electric Maintenance Corporation.**

Dear Tricia:

Please allow this letter to acknowledge and confirm the Workers Compensation Experience Modification for the above.

The EMR's are as follows:

| <u>Effective Year</u> | <u>Experience Modification</u> |
|-----------------------|--------------------------------|
| 10/30/24 to 10/30/25 | 1.00 |

We trust you will find the enclosed in order but should you have any questions please contact our office.

Sincerely,

Julie Kaiser

Julie Kaiser
Client Service Manager

ITEM 680.80324603 - MICROCOMPUTER TRAFFIC CONTROL CABINET BASE

DESCRIPTION:

Under this item the Contractor shall furnish and install a microcomputer traffic signal cabinet base.

The microcomputer traffic signal cabinet base shall be a sheet aluminum base unit designed for use in mounting a NYS Model 330 Microcomputer Traffic Signal Cabinet to a concrete pad for base mounted traffic signal installations.

The base shall be designed to be bolted to a concrete pad using anchor bolts, with the Model 330 cabinet then bolted to the base. Field wiring, detector wiring, etc. are to be brought into and out of the cabinet through the round hole in the top of the base.

MATERIALS:

The base shall be constructed of 5052-H32 aluminum, with full weld seams and shall conform in all respects to the attached drawing.

The top plate of the base shall be constructed of 3/16 inch aluminum and shall have one (1) 8 inch hole cut into it, as shown on the attached drawing.

The base plate of the cabinet shall be constructed of approximately 3/16 inch aluminum and shall be constructed to form a flange with the sides so that the bottom of the base is completely open. Four (4) 1 ¼ inch anchor bolt holes shall be cut into the base plate as shown on the attached drawing.

The sides of the base shall be constructed of 3/16 inch aluminum. A door shall be constructed in the front of the base attaching a piece of ¼ inch aluminum inside the base to form a 1 inch lip. The door shall be constructed of 3/16 inch aluminum and shall fit flush to the front of the base, against the lip. The door shall be secured at the top and bottom with ¼ inch Allen screws.

A 1/2 - 13 NC hex nut to be used for grounding purposes shall be welded to the inside of the front of the base (see drawing).

The base shall be of untreated and unpainted aluminum.

CONSTRUCTION DETAILS:

The requirements of Section 680-3 of the Standard Specifications shall apply.

METHOD OF MEASUREMENT:

This work shall be measured as the number of microcomputer traffic signal cabinet bases installed.

BASIS OF PAYMENT:

The unit price for each microcomputer traffic signal cabinet base installed shall include the cost of all labor, materials and equipment necessary to complete the work. Attach detail from library copy.

ITEM 680.80324603 - MICROCOMPUTER TRAFFIC CONTROL CABINET BASE

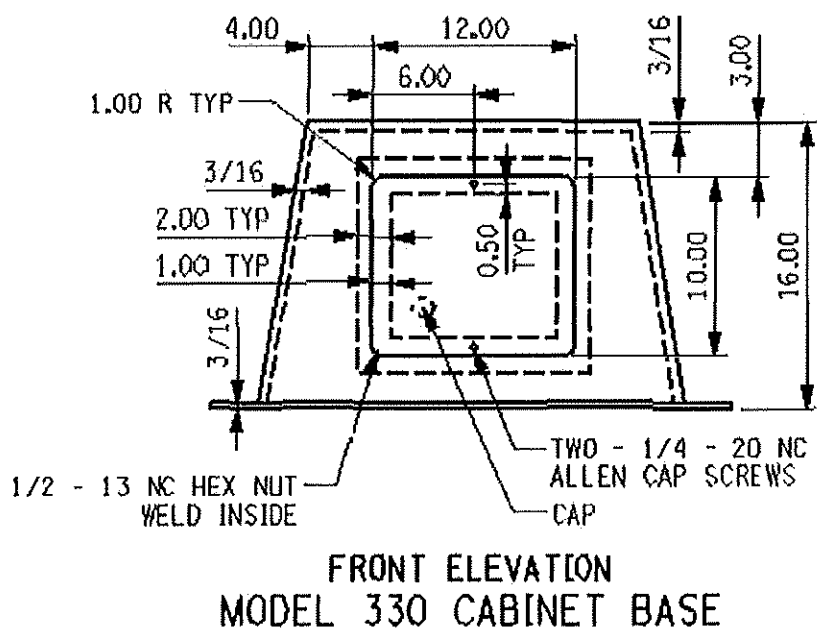
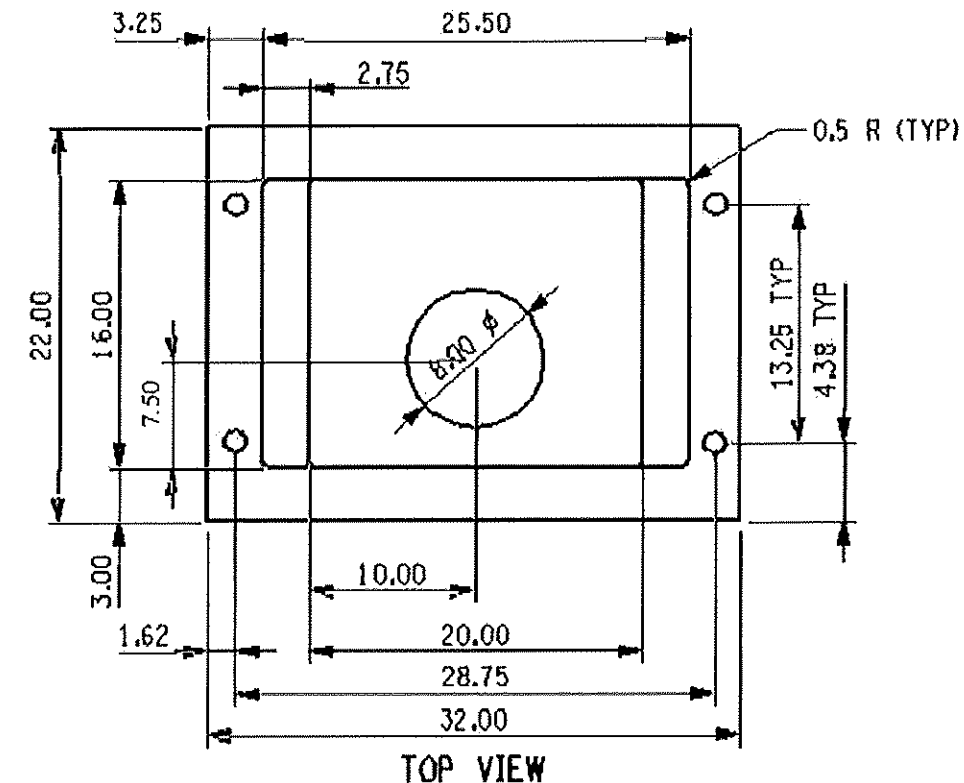

Reset Form

NEW YORK STATE DEPARTMENT OF TRANSPORTATION COST ANALYSIS WORKSHEET (9/22)

Print Form

Contract D# **036472**

Change Order # **001**

Field Change Payment #

CO Item Qty **6**

Section 1 - Existing Contract Item

Use the Item Analysis Report and CONR 22 Composite Report in BI to fill out the below information. Follow Added Work Cost Analysis Decision Flow Chart.

Item Spec No

Unit Bid Price

Bid Qty

Current Contract Qty

Major Item

Minor Item

75% Threshold

Renegotiation Threshold (200% and \$5,000 over original contract amount)

125% Threshold

High Bid Item (over 125%) Yes No

Section 2 - New Contract Item or Continuation of Existing Item

New Item Spec No **680.80324603A**

Renegotiated Qty **6**

Contractor Quoted Unit Price **\$2,890.33**

Method Chosen:

- Original Bid Price Acceptable?
- Contractor agrees to work at the Original Contract Bid Price adjusted for documented changes in material costs, equipment rates, mobilization, and/or site conditions, and bid price is reasonable compensation for the quantity of added work: include letter from contractor, and supporting documentation for adjustments (need price analysis) on CO Header
- Weighted Average Price (WAP) Comparison (must have at least 3 contracts)

Pay Item Catalog Date Range to

PIC Qty Range to N/A

Regional WAP Statewide WAP

Printout of PIC w/ Qty Range, dates, prices attached?

- Comparison to Average of 3 Lowest Bidders (on contract, not item)

Average Price **\$0.00**

Bidder 1

Bidder 2

Bidder 3

Printout of 3 Lowest Bidders on the Contract attached?

- Price Analysis

MURK 26/27 Price Analysis Worksheet attached and all documentation attached?

- Force Account Work (FAW)

FE (Force Estimate) Estimate of Labor, Materials, and Equipment work up included?

FAW (Final) Included with all MURK forms and documentation attached?

Project Conditions/Variance Explanation attached?

Signature *Katelyn A. Vito*

Date **Feb 19, 2026**

RESOLUTION NO.: _____ - 2026

OF

MAY 11, 2026

**A RESOLUTION AUTHORIZING THE CITY MANAGER TO EXECUTE
MASTER FEDERAL-AID LOCAL PROJECT SUPPLEMENTAL AGREEMENT NO. 1
WITH THE NEW YORK STATE DEPARTMENT OF TRANSPORTATION
AUTHORIZING THE IMPLEMENTATION, AND FUNDING IN THE FIRST
INSTANCE 100% OF THE FEDERAL-AID AND STATE "MARCHISELLI" PROGRAM-AID
ELIGIBLE COSTS, OF A TRANSPORTATION FEDERAL-AID PROJECT, AND
APPROPRIATING FUNDS THEREFORE
IN THE TRAFFIC SIGNAL UPGRADES PROJECT (PIN 8758.75)**

WHEREAS, a Project for the City of Newburgh Traffic Signal Upgrades in the City of Newburgh, Orange County, PIN 8758.75 (the "Project") is eligible for funding under Title 23 U.S. Code, as amended, that calls for the apportionment of the costs such program to be borne at the ratio of 80% Federal funds and 20% non-federal funds; and

WHEREAS, the City of Newburgh desires to advance the Project by making a commitment of 100% of the non-federal share of the costs of Construction and Construction Inspection;

NOW, THEREFORE, the Newburgh City Council, duly convened does hereby

RESOLVE, that the Newburgh City Council hereby approves the above-subject project; and it is hereby further

RESOLVED, that the Newburgh City Council hereby authorizes the City of Newburgh to pay in the first instance 100% of the federal and non-federal share of the cost of Construction and Construction Inspection work for the Project or portions thereof; and it is further

RESOLVED, that the sum of \$2,621,000 (\$2,788,000 minus the previous \$167,000) is hereby appropriated from the City's allocation of NYSDOT CHIPS funds and made available to cover the cost of participation in the above phase of the Project; and it is further

RESOLVED, that in the event the full federal and non-federal share costs of the project exceeds the amount appropriated above, the Newburgh City Council shall convene as soon as possible to appropriate said excess amount immediately upon the notification by the City Manager thereof, and it is further

RESOLVED, that the City Manager of the City of Newburgh be and is hereby authorized to execute all necessary Agreements, certifications or reimbursement requests for Federal Aid and/or applicable Marchiselli Aid on behalf of the City of Newburgh with the New York State

Sponsor: **City of Newburgh**
PIN: **8758.75** BIN: **N/A**
Comptroller's Contract No. **D036469**
Supplemental Agreement No. **1**
Date Prepared: **4/15/2026** By: **GC**
Initials

Press F1 for instructions in the blank fields:

SUPPLEMENTAL AGREEMENT No. 1 to D036469 (Comptroller's Contract No.)

This Supplemental Agreement is by and between:

the New York State Department of Transportation ("NYSDOT"), having its principal office at 50 Wolf Road, Albany, NY 12232, on behalf of New York State ("State")
and

City of Newburgh (the Sponsor)
Acting by and through the **City Manager**
with its office at **83 Broadway, Newburgh, NY 12550.**

This amends the existing Agreement between the parties in the following respects only:

Amends a previously adopted Schedule A by (check as applicable):

- amending a project description
- amending the contract end date
- amending the scheduled funding by:
 - adding additional funding (check and enter the # phase(s) as applicable):
 - adding phase **C/CI** which covers eligible costs incurred on/after **4/3/2024**
 - adding phase _____ which covers eligible costs incurred on/after / /
 - increasing funding for a project phase(s)
 - adding a pin extension
 - change from Non-Marchiselli to Marchiselli
 - deleting/reducing funding for a project phase(s)
 - other (_____)

- Amends a previously adopted Schedule "B" (Phases, Sub-phase/Tasks, and Allocation of Responsibility)
- Amends a previously adopted Agreement by replacing the Appendix A dated October 2019 with the Appendix A dated June 2023.
- Amends a previously adopted Agreement by adding:
 - Appendix B M/WBE/SDVOB.
 - Retention Exhibit.
 - Other: _____

Amends the text of the Agreement as follows (insert text below):

Sponsor: **City of Newburgh**
PIN: **8758.75** BIN: **N/A**
Comptroller's Contract No. **D036469**
Supplemental Agreement No. **1**
Date Prepared: **4/15/2026** By: **GC**
Initials

Press F1 for instructions in the blank fields:

IN WITNESS WHEREOF, the parties have caused this Agreement to be executed by their duly authorized officials as of the date first above written.

SPONSOR:

SPONSOR ATTORNEY:

By: _____

By: _____

Print Name: _____

Print Name: _____

Title: _____

STATE OF NEW YORK

)ss.:

COUNTY OF **ORANGE**

On the ___ day of _____ in the year 20__, before me the undersigned personally appeared _____, personally known to me or proved to me on the basis of satisfactory evidence to be the individual(s) whose name(s) is (are) subscribed to the within instrument and acknowledged to me that he/she/they executed the same in his/her/their capacity(ies), and that by his/her/their signature(s) on the instrument, the individual(s), or the person upon behalf of which the individual(s) acted, executed the instrument.

Notary Public

My Commission Expires: _____

APPROVED FOR NYSDOT:

**APPROVED AS TO FORM:
STATE OF NEW YORK ATTORNEY GENERAL**

BY: _____
For Commissioner of Transportation

By: _____
Assistant Attorney General

Agency Certification: In addition to the acceptance of this contract I also certify that original copies of this signature page will be attached to all other exact copies of this contract.

COMPTROLLER'S APPROVAL:

Date: _____

By: _____
For the New York State Comptroller
Pursuant to State Finance Law ' 112

**SCHEDULE A – Description of Project Phase, Funding and Deposit Requirements
 NYSDOT/ State-Local Agreement - Schedule A for PIN 8758.75**

| | |
|---|---|
| OSC Contract #: <u>D036469</u> | Contract Start Date: <u>8/30/2019</u> (mm/dd/yyyy) Contract End Date: <u>8/30/2028</u> (mm/dd/yyyy) <input type="checkbox"/> Check, if date changed from the last Schedule A |
| Purpose: <input type="checkbox"/> Original Standard Agreement <input checked="" type="checkbox"/> Supplemental Schedule A No. 1 | |
| Agreement Type: <input checked="" type="checkbox"/> Locally Administered Municipality/Sponsor (Contract Payee): City of Newburgh Other Municipality/Sponsor (if applicable): <hr/> <input type="checkbox"/> State Administered <i>List participating Municipality(ies) and the % of cost share for each and indicate by checkbox which Municipality this Schedule A applies.</i> <input type="checkbox"/> Municipality: % of Cost share <input type="checkbox"/> Municipality: % of Cost share <input type="checkbox"/> Municipality: % of Cost share | |
| Authorized Project Phase(s) to which this Schedule applies: <input checked="" type="checkbox"/> PE/Design <input type="checkbox"/> ROW Incidentals <input type="checkbox"/> ROW Acquisition <input checked="" type="checkbox"/> Construction/CI/CS | |
| Work Type: HWY SIGNALS | County (If different from Municipality): Orange County |
| <i>(Check, if Project Description has changed from last Schedule A):</i> <input type="checkbox"/> | |
| Project Description: City of Newburgh Traffic Signal Upgrades, City of Newburgh, Orange County | |
| Marchiselli Eligible <input checked="" type="checkbox"/> Yes <input type="checkbox"/> No | |

| A. Summary of Participating Costs FOR ALL PHASES <i>For each PIN Fiscal Share below, show current costs on the rows indicated as "Current". Show the old costs from the previous Schedule A on the row indicated as "Old." All totals will calculate automatically.</i> | | | | | | | |
|--|------------------------------------|-----------------------------|----------------|----------------|--------------|--------------|--|
| PIN Fiscal Share | "Current" or "Old" entry indicator | Funding Source (Percentage) | TOTAL Costs | FEDERAL Funds | STATE Funds | LOCAL Funds | LOCAL DEPOSIT AMOUNT (Required only if State Administered) |
| 8758.75.121 | Current | CMAQ (80%) | \$162,000.00 | \$129,600.00 | \$24,300.00 | \$8,100.00 | \$0.00 |
| | Old | CMAQ (80%) | \$162,000.00 | \$129,600.00 | \$0.00 | \$32,400.00 | \$0.00 |
| 8758.75.221 | Current | CMAQ (80%) | \$ 0.00 | \$0.00 | \$0.00 | \$0.00 | \$0.00 |
| | Old | CMAQ (80%) | \$12,500.00 | \$4,000.00 | \$7,500.00 | \$1,000.00 | \$0.00 |
| 8758.75.321 | Current | STBG (80%) | \$1,797,000.00 | \$1,437,600.00 | \$269,550.00 | \$89,850.00 | \$0.00 |
| | Old | | \$ 0.00 | \$0.00 | \$0.00 | \$0.00 | \$0.00 |
| 8758.75.322 | Current | CRP (80%) | \$501,000.00 | \$400,800.00 | \$75,150.00 | \$25,050.00 | \$0.00 |
| | Old | | \$ 0.00 | \$0.00 | \$0.00 | \$0.00 | \$0.00 |
| 8758.75.323 | Current | CRP (80%) | \$328,000.00 | \$262,400.00 | \$49,200.00 | \$16,400.00 | \$0.00 |
| | Old | | \$ 0.00 | \$0.00 | \$0.00 | \$0.00 | \$0.00 |
| . . | Current | | \$ 0.00 | \$0.00 | \$0.00 | | \$0.00 |
| | Old | | \$ 0.00 | \$0.00 | \$0.00 | \$0.00 | \$0.00 |
| . . | Current | | \$ 0.00 | \$0.00 | \$0.00 | \$0.00 | \$0.00 |
| | Old | | \$ 0.00 | \$0.00 | \$0.00 | \$0.00 | \$0.00 |
| . . | Current | | \$ 0.00 | \$0.00 | \$0.00 | \$0.00 | \$0.00 |
| | Old | | \$ 0.00 | \$0.00 | \$0.00 | \$0.00 | \$0.00 |
| . . | Current | | \$ 0.00 | \$0.00 | \$0.00 | \$0.00 | \$0.00 |
| | Old | | \$ 0.00 | \$0.00 | \$0.00 | \$0.00 | \$0.00 |
| . . | Current | | \$ 0.00 | \$0.00 | \$0.00 | \$0.00 | \$0.00 |
| | Old | | \$ 0.00 | \$0.00 | \$0.00 | \$0.00 | \$0.00 |
| TOTAL CURRENT COSTS: | | | \$2,788,000.00 | \$2,230,400.00 | \$418,200.00 | \$139,400.00 | \$ 0.00 |

APPENDIX A

STANDARD CLAUSES FOR NEW YORK STATE CONTRACTS

**PLEASE RETAIN THIS DOCUMENT
FOR FUTURE REFERENCE.**

TABLE OF CONTENTS

| | Page |
|---|-------------|
| 1. Executory Clause | 3 |
| 2. Non-Assignment Clause | 3 |
| 3. Comptroller's Approval | 3 |
| 4. Workers' Compensation Benefits | 3 |
| 5. Non-Discrimination Requirements | 3 |
| 6. Wage and Hours Provisions | 3-4 |
| 7. Non-Collusive Bidding Certification | 4 |
| 8. International Boycott Prohibition | 4 |
| 9. Set-Off Rights | 4 |
| 10. Records | 4 |
| 11. Identifying Information and Privacy Notification | 4 |
| 12. Equal Employment Opportunities For Minorities and Women | 5 |
| 13. Conflicting Terms | 5 |
| 14. Governing Law | 5 |
| 15. Late Payment | 5 |
| 16. No Arbitration | 5 |
| 17. Service of Process | 5 |
| 18. Prohibition on Purchase of Tropical Hardwoods | 5-6 |
| 19. MacBride Fair Employment Principles | 6 |
| 20. Omnibus Procurement Act of 1992 | 6 |
| 21. Reciprocity and Sanctions Provisions | 6 |
| 22. Compliance with Breach Notification and Data Security Laws | 6 |
| 23. Compliance with Consultant Disclosure Law | 6 |
| 24. Procurement Lobbying | 7 |
| 25. Certification of Registration to Collect Sales and Compensating Use Tax by Certain State Contractors, Affiliates and Subcontractors | 7 |
| 26. Iran Divestment Act | 7 |
| 27. Admissibility of Contract | 7 |

STANDARD CLAUSES FOR NYS CONTRACTS

The parties to the attached contract, license, lease, amendment or other agreement of any kind (hereinafter, “the contract” or “this contract”) agree to be bound by the following clauses which are hereby made a part of the contract (the word “Contractor” herein refers to any party other than the State, whether a contractor, licenser, licensee, lessor, lessee or any other party):

1. EXECUTORY CLAUSE. In accordance with Section 41 of the State Finance Law, the State shall have no liability under this contract to the Contractor or to anyone else beyond funds appropriated and available for this contract.

2. NON-ASSIGNMENT CLAUSE. In accordance with Section 138 of the State Finance Law, this contract may not be assigned by the Contractor or its right, title or interest therein assigned, transferred, conveyed, sublet or otherwise disposed of without the State’s previous written consent, and attempts to do so are null and void. Notwithstanding the foregoing, such prior written consent of an assignment of a contract let pursuant to Article XI of the State Finance Law may be waived at the discretion of the contracting agency and with the concurrence of the State Comptroller where the original contract was subject to the State Comptroller’s approval, where the assignment is due to a reorganization, merger or consolidation of the Contractor’s business entity or enterprise. The State retains its right to approve an assignment and to require that any Contractor demonstrate its responsibility to do business with the State. The Contractor may, however, assign its right to receive payments without the State’s prior written consent unless this contract concerns Certificates of Participation pursuant to Article 5-A of the State Finance Law.

3. COMPTROLLER’S APPROVAL. In accordance with Section 112 of the State Finance Law, if this contract exceeds \$50,000 (or \$75,000 for State University of New York or City University of New York contracts for goods, services, construction and printing, and \$150,000 for State University Health Care Facilities) or if this is an amendment for any amount to a contract which, as so amended, exceeds said statutory amount, or if, by this contract, the State agrees to give something other than money when the value or reasonably estimated value of such consideration exceeds \$25,000, it shall not be valid, effective or binding upon the State until it has been approved by the State Comptroller and filed in his office. Comptroller’s approval of contracts let by the Office of General Services, either for itself or its customer agencies by the Office of General Services Business Services Center, is required when such contracts exceed \$85,000. Comptroller’s approval of contracts established as centralized contracts through the Office of General Services is required when such contracts exceed \$125,000, and when a purchase order or other procurement transaction issued under such centralized contract exceeds \$200,000.

4. WORKERS’ COMPENSATION BENEFITS. In accordance with Section 142 of the State Finance Law, this contract shall be void and of no force and effect unless the Contractor shall provide and maintain coverage during the life of this contract for the benefit of such employees as are required to be covered by the provisions of the Workers’ Compensation Law.

5. NON-DISCRIMINATION REQUIREMENTS. To the extent required by Article 15 of the Executive Law (also known as the Human Rights Law) and all other State and Federal statutory and constitutional non-discrimination provisions, the Contractor will not discriminate against any employee or applicant for employment, nor subject any individual to harassment, because of age, race, creed, color, national origin, citizenship or immigration status, sexual orientation, gender identity or expression, military status, sex, disability, predisposing genetic characteristics, familial status, marital status, or domestic violence victim status or because the individual has opposed any practices forbidden under the Human Rights Law or has filed a complaint, testified, or assisted in any proceeding under the Human Rights Law. Furthermore, in accordance with Section 220-e of the Labor Law, if this is a contract for the construction, alteration or repair of any public building or public work or for the manufacture, sale or distribution of materials, equipment or supplies, and to the extent that this contract shall be performed within the State of New York, Contractor agrees that neither it nor its subcontractors shall, by reason of race, creed, color, disability, sex, or national origin: (a) discriminate in hiring against any New York State citizen who is qualified and available to perform the work; or (b) discriminate against or intimidate any employee hired for the performance of work under this contract. If this is a building service contract as defined in Section 230 of the Labor Law, then, in accordance with Section 239 thereof, Contractor agrees that neither it nor its subcontractors shall by reason of race, creed, color, national origin, age, sex or disability: (a) discriminate in hiring against any New York State citizen who is qualified and available to perform the work; or (b) discriminate against or intimidate any employee hired for the performance of work under this contract. Contractor is subject to fines of \$50.00 per person per day for any violation of Section 220-e or Section 239 as well as possible termination of this contract and forfeiture of all moneys due hereunder for a second or subsequent violation.

6. WAGE AND HOURS PROVISIONS. If this is a public work contract covered by Article 8 of the Labor Law or a building service contract covered by Article 9 thereof, neither Contractor’s employees nor the employees of its subcontractors may be required or permitted to work more than the number of hours or days stated in said statutes, except as otherwise provided in the Labor Law and as set forth in prevailing wage and supplement schedules issued by the State Labor Department. Furthermore, Contractor and its subcontractors must pay at least the prevailing wage rate and pay or provide the prevailing supplements, including the premium rates for overtime pay, as determined by the State Labor Department in

accordance with the Labor Law. Additionally, effective April 28, 2008, if this is a public work contract covered by Article 8 of the Labor Law, the Contractor understands and agrees that the filing of payrolls in a manner consistent with Subdivision 3-a of Section 220 of the Labor Law shall be a condition precedent to payment by the State of any State approved sums due and owing for work done upon the project.

7. NON-COLLUSIVE BIDDING CERTIFICATION. In accordance with Section 139-d of the State Finance Law, if this contract was awarded based upon the submission of bids, Contractor affirms, under penalty of perjury, that its bid was arrived at independently and without collusion aimed at restricting competition. Contractor further affirms that, at the time Contractor submitted its bid, an authorized and responsible person executed and delivered to the State a non-collusive bidding certification on Contractor's behalf.

8. INTERNATIONAL BOYCOTT PROHIBITION. In accordance with Section 220-f of the Labor Law and Section 139-h of the State Finance Law, if this contract exceeds \$5,000, the Contractor agrees, as a material condition of the contract, that neither the Contractor nor any substantially owned or affiliated person, firm, partnership or corporation has participated, is participating, or shall participate in an international boycott in violation of the federal Export Administration Act of 1979 (50 USC App. Sections 2401 et seq.) or regulations thereunder. If such Contractor, or any of the aforesaid affiliates of Contractor, is convicted or is otherwise found to have violated said laws or regulations upon the final determination of the United States Commerce Department or any other appropriate agency of the United States subsequent to the contract's execution, such contract, amendment or modification thereto shall be rendered forfeit and void. The Contractor shall so notify the State Comptroller within five (5) business days of such conviction, determination or disposition of appeal (2 NYCRR § 105.4).

9. SET-OFF RIGHTS. The State shall have all of its common law, equitable and statutory rights of set-off. These rights shall include, but not be limited to, the State's option to withhold for the purposes of set-off any moneys due to the Contractor under this contract up to any amounts due and owing to the State with regard to this contract, any other contract with any State department or agency, including any contract for a term commencing prior to the term of this contract, plus any amounts due and owing to the State for any other reason including, without limitation, tax delinquencies, fee delinquencies or monetary penalties relative thereto. The State shall exercise its set-off rights in accordance with normal State practices including, in cases of set-off pursuant to an audit, the finalization of such audit by the State agency, its representatives, or the State Comptroller.

10. RECORDS. The Contractor shall establish and maintain complete and accurate books, records, documents, accounts and other evidence directly pertinent to performance under this contract (hereinafter, collectively, the "Records"). The Records

must be kept for the balance of the calendar year in which they were made and for six (6) additional years thereafter. The State Comptroller, the Attorney General and any other person or entity authorized to conduct an examination, as well as the agency or agencies involved in this contract, shall have access to the Records during normal business hours at an office of the Contractor within the State of New York or, if no such office is available, at a mutually agreeable and reasonable venue within the State, for the term specified above for the purposes of inspection, auditing and copying. The State shall take reasonable steps to protect from public disclosure any of the Records which are exempt from disclosure under Section 87 of the Public Officers Law (the "Statute") provided that: (i) the Contractor shall timely inform an appropriate State official, in writing, that said records should not be disclosed; and (ii) said records shall be sufficiently identified; and (iii) designation of said records as exempt under the Statute is reasonable. Nothing contained herein shall diminish, or in any way adversely affect, the State's right to discovery in any pending or future litigation.

11. IDENTIFYING INFORMATION AND PRIVACY NOTIFICATION. (a) Identification Number(s). Every invoice or New York State Claim for Payment submitted to a New York State agency by a payee, for payment for the sale of goods or services or for transactions (e.g., leases, easements, licenses, etc.) related to real or personal property must include the payee's identification number. The number is any or all of the following: (i) the payee's Federal employer identification number, (ii) the payee's Federal social security number, and/or (iii) the payee's Vendor Identification Number assigned by the Statewide Financial System. Failure to include such number or numbers may delay payment. Where the payee does not have such number or numbers, the payee, on its invoice or Claim for Payment, must give the reason or reasons why the payee does not have such number or numbers.

(b) Privacy Notification. (1) The authority to request the above personal information from a seller of goods or services or a lessor of real or personal property, and the authority to maintain such information, is found in Section 5 of the State Tax Law. Disclosure of this information by the seller or lessor to the State is mandatory. The principal purpose for which the information is collected is to enable the State to identify individuals, businesses and others who have been delinquent in filing tax returns or may have understated their tax liabilities and to generally identify persons affected by the taxes administered by the Commissioner of Taxation and Finance. The information will be used for tax administration purposes and for any other purpose authorized by law. (2) The personal information is requested by the purchasing unit of the agency contracting to purchase the goods or services or lease the real or personal property covered by this contract or lease. The information is maintained in the Statewide Financial System by the Vendor Management Unit within the Bureau of State Expenditures, Office of the State Comptroller, 110 State Street, Albany, New York 12236.

12. EQUAL EMPLOYMENT OPPORTUNITIES FOR MINORITIES AND WOMEN.

In accordance with Section 312 of the Executive Law and 5 NYCRR Part 143, if this contract is: (i) a written agreement or purchase order instrument, providing for a total expenditure in excess of \$25,000.00, whereby a contracting agency is committed to expend or does expend funds in return for labor, services, supplies, equipment, materials or any combination of the foregoing, to be performed for, or rendered or furnished to the contracting agency; or (ii) a written agreement in excess of \$100,000.00 whereby a contracting agency is committed to expend or does expend funds for the acquisition, construction, demolition, replacement, major repair or renovation of real property and improvements thereon; or (iii) a written agreement in excess of \$100,000.00 whereby the owner of a State assisted housing project is committed to expend or does expend funds for the acquisition, construction, demolition, replacement, major repair or renovation of real property and improvements thereon for such project, then the following shall apply and by signing this agreement the Contractor certifies and affirms that it is Contractor's equal employment opportunity policy that:

(a) The Contractor will not discriminate against employees or applicants for employment because of race, creed, color, national origin, sex, age, disability or marital status, shall make and document its conscientious and active efforts to employ and utilize minority group members and women in its work force on State contracts and will undertake or continue existing programs of affirmative action to ensure that minority group members and women are afforded equal employment opportunities without discrimination. Affirmative action shall mean recruitment, employment, job assignment, promotion, upgradings, demotion, transfer, layoff, or termination and rates of pay or other forms of compensation;

(b) at the request of the contracting agency, the Contractor shall request each employment agency, labor union, or authorized representative of workers with which it has a collective bargaining or other agreement or understanding, to furnish a written statement that such employment agency, labor union or representative will not discriminate on the basis of race, creed, color, national origin, sex, age, disability or marital status and that such union or representative will affirmatively cooperate in the implementation of the Contractor's obligations herein; and

(c) the Contractor shall state, in all solicitations or advertisements for employees, that, in the performance of the State contract, all qualified applicants will be afforded equal employment opportunities without discrimination because of race, creed, color, national origin, sex, age, disability or marital status.

Contractor will include the provisions of "(a), (b) and (c)" above, in every subcontract over \$25,000.00 for the construction, demolition, replacement, major repair, renovation, planning or design of real property and improvements thereon (the "Work") except where the Work is for the beneficial use of the Contractor. Section 312 does not

apply to: (i) work, goods or services unrelated to this contract; or (ii) employment outside New York State. The State shall consider compliance by a contractor or subcontractor with the requirements of any federal law concerning equal employment opportunity which effectuates the purpose of this clause. The contracting agency shall determine whether the imposition of the requirements of the provisions hereof duplicate or conflict with any such federal law and if such duplication or conflict exists, the contracting agency shall waive the applicability of Section 312 to the extent of such duplication or conflict. Contractor will comply with all duly promulgated and lawful rules and regulations of the Department of Economic Development's Division of Minority and Women's Business Development pertaining hereto.

13. CONFLICTING TERMS. In the event of a conflict between the terms of the contract (including any and all attachments thereto and amendments thereof) and the terms of this Appendix A, the terms of this Appendix A shall control.

14. GOVERNING LAW. This contract shall be governed by the laws of the State of New York except where the Federal supremacy clause requires otherwise.

15. LATE PAYMENT. Timeliness of payment and any interest to be paid to Contractor for late payment shall be governed by Article 11-A of the State Finance Law to the extent required by law.

16. NO ARBITRATION. Disputes involving this contract, including the breach or alleged breach thereof, may not be submitted to binding arbitration (except where statutorily authorized), but must, instead, be heard in a court of competent jurisdiction of the State of New York.

17. SERVICE OF PROCESS. In addition to the methods of service allowed by the State Civil Practice Law & Rules ("CPLR"), Contractor hereby consents to service of process upon it by registered or certified mail, return receipt requested. Service hereunder shall be complete upon Contractor's actual receipt of process or upon the State's receipt of the return thereof by the United States Postal Service as refused or undeliverable. Contractor must promptly notify the State, in writing, of each and every change of address to which service of process can be made. Service by the State to the last known address shall be sufficient. Contractor will have thirty (30) calendar days after service hereunder is complete in which to respond.

18. PROHIBITION ON PURCHASE OF TROPICAL HARDWOODS. The Contractor certifies and warrants that all wood products to be used under this contract award will be in accordance with, but not limited to, the specifications and provisions of Section 165 of the State Finance Law, (Use of Tropical Hardwoods) which prohibits purchase and use of tropical hardwoods, unless specifically exempted, by the State or any governmental agency or political subdivision or public benefit corporation. Qualification for an exemption under this

law will be the responsibility of the contractor to establish to meet with the approval of the State.

In addition, when any portion of this contract involving the use of woods, whether supply or installation, is to be performed by any subcontractor, the prime Contractor will indicate and certify in the submitted bid proposal that the subcontractor has been informed and is in compliance with specifications and provisions regarding use of tropical hardwoods as detailed in § 165 State Finance Law. Any such use must meet with the approval of the State; otherwise, the bid may not be considered responsive. Under bidder certifications, proof of qualification for exemption will be the responsibility of the Contractor to meet with the approval of the State.

19. MACBRIDE FAIR EMPLOYMENT PRINCIPLES. In accordance with the MacBride Fair Employment Principles (Chapter 807 of the Laws of 1992), the Contractor hereby stipulates that the Contractor either (a) has no business operations in Northern Ireland, or (b) shall take lawful steps in good faith to conduct any business operations in Northern Ireland in accordance with the MacBride Fair Employment Principles (as described in Section 165 of the New York State Finance Law), and shall permit independent monitoring of compliance with such principles.

20. OMNIBUS PROCUREMENT ACT OF 1992. It is the policy of New York State to maximize opportunities for the participation of New York State business enterprises, including minority- and women-owned business enterprises as bidders, subcontractors and suppliers on its procurement contracts.

Information on the availability of New York State subcontractors and suppliers is available from:

NYS Department of Economic Development
Division for Small Business and Technology Development
625 Broadway
Albany, New York 12245
Telephone: 518-292-5100

A directory of certified minority- and women-owned business enterprises is available from:

NYS Department of Economic Development
Division of Minority and Women's Business Development
633 Third Avenue 33rd Floor
New York, NY 10017
646-846-7364
email: mwbebusinessdev@esd.ny.gov
<https://ny.newnycontracts.com/FrontEnd/searchcertifieddirectory.asp>

The Omnibus Procurement Act of 1992 (Chapter 844 of the Laws of 1992, codified in State Finance Law § 139-i and Public Authorities Law § 2879(3)(n)-(p)) requires that by signing this bid proposal or contract, as applicable, Contractors certify that whenever the total bid amount is greater than \$1 million:

(a) The Contractor has made reasonable efforts to encourage the participation of New York State Business Enterprises as suppliers and subcontractors, including certified minority- and women-owned business enterprises, on this project, and has retained the documentation of these efforts to be provided upon request to the State;

(b) The Contractor has complied with the Federal Equal Opportunity Act of 1972 (P.L. 92-261), as amended;

(c) The Contractor agrees to make reasonable efforts to provide notification to New York State residents of employment opportunities on this project through listing any such positions with the Job Service Division of the New York State Department of Labor, or providing such notification in such manner as is consistent with existing collective bargaining contracts or agreements. The Contractor agrees to document these efforts and to provide said documentation to the State upon request; and

(d) The Contractor acknowledges notice that the State may seek to obtain offset credits from foreign countries as a result of this contract and agrees to cooperate with the State in these efforts.

21. RECIPROCITY AND SANCTIONS PROVISIONS. Bidders are hereby notified that if their principal place of business is located in a country, nation, province, state or political subdivision that penalizes New York State vendors, and if the goods or services they offer will be substantially produced or performed outside New York State, the Omnibus Procurement Act 1994 and 2000 amendments (Chapter 684 and Chapter 383, respectively, codified in State Finance Law § 165(6) and Public Authorities Law § 2879(5)) require that they be denied contracts which they would otherwise obtain. NOTE: As of May 2023, the list of discriminatory jurisdictions subject to this provision includes the states of South Carolina, Alaska, West Virginia, Wyoming, Louisiana and Hawaii.

22. COMPLIANCE WITH BREACH NOTIFICATION AND DATA SECURITY LAWS. Contractor shall comply with the provisions of the New York State Information Security Breach and Notification Act (General Business Law §§ 899-aa and 899-bb and State Technology Law § 208).

23. COMPLIANCE WITH CONSULTANT DISCLOSURE LAW. If this is a contract for consulting services, defined for purposes of this requirement to include analysis, evaluation, research, training, data processing, computer programming, engineering, environmental, health, and mental health services, accounting, auditing, paralegal, legal or similar services, then, in accordance with Section 163 (4)(g) of the State Finance Law (as amended by Chapter 10 of the Laws of 2006), the Contractor shall timely, accurately and properly comply with the requirement to submit an annual employment report for the contract to the agency that awarded the contract, the Department of Civil Service and the State Comptroller.

24. PROCUREMENT LOBBYING. To the extent this agreement is a “procurement contract” as defined by State Finance Law §§ 139-j and 139-k, by signing this agreement the contractor certifies and affirms that all disclosures made in accordance with State Finance Law §§ 139-j and 139-k are complete, true and accurate. In the event such certification is found to be intentionally false or intentionally incomplete, the State may terminate the agreement by providing written notification to the Contractor in accordance with the terms of the agreement.

25. CERTIFICATION OF REGISTRATION TO COLLECT SALES AND COMPENSATING USE TAX BY CERTAIN STATE CONTRACTORS, AFFILIATES AND SUBCONTRACTORS.

To the extent this agreement is a contract as defined by Tax Law § 5-a, if the contractor fails to make the certification required by Tax Law § 5-a or if during the term of the contract, the Department of Taxation and Finance or the covered agency, as defined by Tax Law § 5-a, discovers that the certification, made under penalty of perjury, is false, then such failure to file or false certification shall be a material breach of this contract and this contract may be terminated, by providing written notification to the Contractor in accordance with the terms of the agreement, if the covered agency determines that such action is in the best interest of the State.

26. IRAN DIVESTMENT ACT. By entering into this Agreement, Contractor certifies in accordance with State Finance Law § 165-a that it is not on the “Entities Determined to be Non-Responsive Bidders/Offerers pursuant to the New York State Iran Divestment Act of 2012” (“Prohibited Entities List”) posted at: <https://ogs.ny.gov/iran-divestment-act-2012>

Contractor further certifies that it will not utilize on this Contract any subcontractor that is identified on the Prohibited Entities List. Contractor agrees that should it seek to renew or extend this Contract, it must provide the same certification at the time the Contract is renewed or extended. Contractor also agrees that any proposed Assignee of this Contract will be required to certify that it is not on the Prohibited Entities List before the contract assignment will be approved by the State.

During the term of the Contract, should the state agency receive information that a person (as defined in State Finance Law § 165-a) is in violation of the above-referenced certifications, the state agency will review such information and offer the person an opportunity to respond. If the person fails to demonstrate that it has ceased its engagement in the investment activity which is in violation of the Act within 90 days after the determination of such violation, then the state agency shall take such action as may be appropriate and provided for by law, rule, or contract, including, but not limited to, imposing sanctions, seeking compliance, recovering damages, or declaring the Contractor in default.

The state agency reserves the right to reject any bid, request for assignment, renewal or extension for an entity that appears on the Prohibited Entities List prior to the award, assignment, renewal or extension of a contract, and to pursue a responsibility review with respect to any entity that is awarded a contract and appears on the Prohibited Entities list after contract award.

27. ADMISSIBILITY OF REPRODUCTION OF CONTRACT. Notwithstanding the best evidence rule or any other legal principle or rule of evidence to the contrary, the Contractor acknowledges and agrees that it waives any and all objections to the admissibility into evidence at any court proceeding or to the use at any examination before trial of an electronic reproduction of this contract, in the form approved by the State Comptroller, if such approval was required, regardless of whether the original of said contract is in existence.

SAMPLE RESOLUTION BY MUNICIPALITY
(Locally Administered Project)
RESOLUTION NUMBER: _____

Authorizing the implementation, and funding in the first instance 100% of the federal-aid and State "Marchiselli" Program-aid eligible costs, of a transportation federal-aid project, and appropriating funds therefore.

WHEREAS, a Project for the City of Newburgh Traffic Signal Upgrades in the City of Newburgh, Orange County, PIN 8758.75 (the "Project") is eligible for funding under Title 23 U.S. Code, as amended, that calls for the apportionment of the costs such program to be borne at the ratio of 80% Federal funds and 20% non-federal funds; and

WHEREAS, the City of Newburgh desires to advance the Project by making a commitment of 100% of the non-federal share of the costs of Construction and Construction Inspection.

NOW, THEREFORE, the Newburgh City Council, duly convened does hereby

RESOLVE, that the Newburgh City Council hereby approves the above-subject project; and it is hereby further

RESOLVED, that the Newburgh City Council hereby authorizes the City of Newburgh to pay in the first instance 100% of the federal and non-federal share of the cost of Construction and Construction Inspection work for the Project or portions thereof; and it is further

RESOLVED, that the sum of **\$2,621,000 (\$2,788,000 minus the previous \$167,000)** is hereby appropriated from _____ [or, appropriated pursuant to _____] and made available to cover the cost of participation in the above phase of the Project; and it is further

RESOLVED, that in the event the full federal and non-federal share costs of the project exceeds the amount appropriated above, the Newburgh City Council shall convene as soon as possible to appropriate said excess amount immediately upon the notification by the City Manager thereof, and it is further

RESOLVED, that the City Manager of the City of Newburgh be and is hereby authorized to execute all necessary Agreements, certifications or reimbursement requests for Federal Aid and/or applicable Marchiselli Aid on behalf of the City of Newburgh with the New York State Department of Transportation in connection with the advancement or approval of the Project and providing for the administration of the Project and the municipality's first instance funding of project costs and permanent funding of the local share of federal-aid and state-aid eligible Project costs and all Project costs within appropriations therefore that are not so eligible, and it is further

RESOLVED, that in addition to the City Manager, the following municipal titles: Commissioner of Public Works, City Engineer, City Comptroller, _____ are also hereby authorized to execute any necessary Agreements or certifications on behalf of the Municipality/Sponsor, with NYSDOT in connection with the advancement or approval of the project identified in the State/Local Agreement;

RESOLVED, that a certified copy of this resolution be filed with the New York State Commissioner of Transportation by attaching it to any necessary Agreement in connection with the Project, and it is further

RESOLVED, this Resolution shall take effect immediately.

STATE OF NEW YORK)
) SS:
COUNTY OF ORANGE)

I, _____, Clerk of the City of Newburgh, New York, do hereby certify that I have compared the foregoing copy of this Resolution with the original on file in my office, and that the same is a true and correct transcript of said original Resolution and of the whole thereof, as duly adopted by said _____ at a meeting duly called and held at the _____ on _____ by the required and necessary vote of the members to approve the Resolution.

WITNESS My Hand and the Official Seal of the City of Newburgh, New York, this _____ day of _____, 2026.

Clerk, City of Newburgh

RESOLUTION NO.: _____ - 2026

OF

MAY 11, 2026

**A RESOLUTION AUTHORIZING THE CITY MANAGER TO EXECUTE
MASTER FEDERAL-AID LOCAL PROJECT SUPPLEMENTAL AGREEMENT NO. 1
WITH THE NEW YORK STATE DEPARTMENT OF TRANSPORTATION
AUTHORIZING THE IMPLEMENTATION, AND FUNDING IN THE FIRST
INSTANCE 100% OF THE FEDERAL-AID AND STATE "MARCHISELLI" PROGRAM-AID
ELIGIBLE COSTS, OF A TRANSPORTATION FEDERAL-AID PROJECT, AND
APPROPRIATING FUNDS THEREFORE
IN THE TRAFFIC SIGNAL UPGRADES PROJECT (PIN 8005.26)**

WHEREAS, a Project for the Broadway Pedestrian and Traffic Signal Improvements in the City of Newburgh, PIN 8005.26 (the "Project") is eligible for funding under Title 23 U.S. Code, as amended, that calls for the apportionment of the costs such program to be borne at the ratio of 80% Federal funds and 20% non-federal funds; and

WHEREAS, the City of Newburgh desires to advance the Project by making a commitment of 100% of the non-federal share of the costs of construction and construction inspection;

NOW, THEREFORE, the Newburgh City Council, duly convened does hereby

RESOLVE, that the Newburgh City Council hereby approves the above-subject project; and it is hereby further

RESOLVED, that the Newburgh City Council hereby authorizes the City of Newburgh to pay in the first instance 100% of the federal and non-federal share of the cost of construction and construction inspection work for the Project or portions thereof; and it is further

RESOLVED, that the sum of \$7,942,600 (\$8,792,600 minus the previous \$850,000) is hereby appropriated from City's allocation of NYSDOT CHIPS funds and made available to cover the cost of participation in the above phase of the Project; and it is further

RESOLVED, that in the event the full federal and non-federal share costs of the project exceeds the amount appropriated above, the Newburgh City Council shall convene as soon as possible to appropriate said excess amount immediately upon the notification by the City Manager thereof, and it is further

RESOLVED, that the City Manager of the City of Newburgh be and is hereby authorized to execute all necessary Agreements, certifications or reimbursement requests for Federal Aid and/or applicable Marchiselli Aid on behalf of the City of Newburgh with the New York State

Sponsor: **City of Newburgh**
PIN: **8005.26** BIN: **N/A**
Comptroller's Contract No. **D036472**
Supplemental Agreement No. **1**
Date Prepared: **10/2/2025** By: **GC**
Initials

Press F1 for instructions in the blank fields:

SUPPLEMENTAL AGREEMENT No. 1 to D036472 (Comptroller's Contract No.)

This Supplemental Agreement is by and between:

the New York State Department of Transportation ("NYSDOT"), having its principal office at 50 Wolf Road, Albany, NY 12232, on behalf of New York State ("State")
and

City of Newburgh (the Sponsor)
Acting by and through the **City Manager**
with its office at **83 Broadway, Newburgh, NY 12550.**

This amends the existing Agreement between the parties in the following respects only:

Amends a previously adopted Schedule A by (check as applicable):

- amending a project description
- amending the contract end date
- amending the scheduled funding by:
 - adding additional funding (check and enter the # phase(s) as applicable):
 - adding phase **C/CI** which covers eligible costs incurred on/after **4/3/2024**
 - adding phase _____ which covers eligible costs incurred on/after / /
 - increasing funding for a project phase(s)
 - adding a pin extension
 - change from Non-Marchiselli to Marchiselli
 - deleting/reducing funding for a project phase(s)
 - other (_____)

- Amends a previously adopted Schedule "B" (Phases, Sub-phase/Tasks, and Allocation of Responsibility)
- Amends a previously adopted Agreement by replacing the Appendix A dated October 2019 with the Appendix A dated June 2023.
- Amends a previously adopted Agreement by adding:
 - Appendix B M/WBE/SDVOB.
 - Retention Exhibit.
 - Other: _____

Amends the text of the Agreement as follows (insert text below):

Sponsor: **City of Newburgh**
PIN: **8005.26** BIN: **N/A**
Comptroller's Contract No. **D036472**
Supplemental Agreement No. **1**
Date Prepared: **10/2/2025** By: **GC**
Initials

Press F1 for instructions in the blank fields:

IN WITNESS WHEREOF, the parties have caused this Agreement to be executed by their duly authorized officials as of the date first above written.

SPONSOR:

SPONSOR ATTORNEY:

By: _____

By: _____

Print Name: _____

Print Name: _____

Title: _____

STATE OF NEW YORK

)ss.:

COUNTY OF **ORANGE**

On the ___ day of _____ in the year 20__, before me the undersigned personally appeared _____, personally known to me or proved to me on the basis of satisfactory evidence to be the individual(s) whose name(s) is (are) subscribed to the within instrument and acknowledged to me that he/she/they executed the same in his/her/their capacity(ies), and that by his/her/their signature(s) on the instrument, the individual(s), or the person upon behalf of which the individual(s) acted, executed the instrument.

Notary Public

My Commission Expires: _____

APPROVED FOR NYSDOT:

**APPROVED AS TO FORM:
STATE OF NEW YORK ATTORNEY GENERAL**

BY: _____
For Commissioner of Transportation

By: _____
Assistant Attorney General

Agency Certification: In addition to the acceptance of this contract I also certify that original copies of this signature page will be attached to all other exact copies of this contract.

COMPTROLLER'S APPROVAL:

Date: _____

By: _____
For the New York State Comptroller
Pursuant to State Finance Law ' 112

SCHEDULE A – Description of Project Phase, Funding and Deposit Requirements
NYS DOT/ State-Local Agreement - Schedule A for PIN 8005.26

| | |
|---|--|
| OSC Contract #: <u>D036472</u> | Contract Start Date: <u>8/6/2019</u> (mm/dd/yyyy) Contract End Date: <u>8/30/2028</u> (mm/dd/yyyy) <input type="checkbox"/> Check, if date changed from the last Schedule A |
| Purpose: <input type="checkbox"/> Original Standard Agreement <input checked="" type="checkbox"/> Supplemental Schedule A No. 1 | |
| Agreement Type: <input checked="" type="checkbox"/> Locally Administered Municipality/Sponsor (Contract Payee): City of Newburgh Other Municipality/Sponsor (if applicable): <hr/> <input type="checkbox"/> State Administered <i>List participating Municipality(ies) and the % of cost share for each and indicate by checkbox which Municipality this Schedule A applies.</i> <input type="checkbox"/> Municipality: % of Cost share <input type="checkbox"/> Municipality: % of Cost share <input type="checkbox"/> Municipality: % of Cost share | |
| Authorized Project Phase(s) to which this Schedule applies: <input checked="" type="checkbox"/> PE/Design <input checked="" type="checkbox"/> ROW Incidentals <input type="checkbox"/> ROW Acquisition <input checked="" type="checkbox"/> Construction/CI/CS | |
| Work Type: BIKE/PED./FACILITIES | County (If different from Municipality): Orange County |
| <i>(Check, if Project Description has changed from last Schedule A):</i> <input type="checkbox"/> | |
| Project Description: Broadway Pedestrian and Traffic Signal Improvements, City of Newburgh, Orange County. | |
| Marchiselli Eligible <input checked="" type="checkbox"/> Yes <input type="checkbox"/> No | |

| A. Summary of Participating Costs FOR ALL PHASES <small>For each PIN Fiscal Share below, show current costs on the rows indicated as "Current". Show the old costs from the previous Schedule A on the row indicated as "Old." All totals will calculate automatically.</small> | | | | | | | |
|--|------------------------------------|-----------------------------|----------------|----------------|----------------|----------------|--|
| PIN Fiscal Share | "Current" or "Old" entry indicator | Funding Source (Percentage) | TOTAL Costs | FEDERAL Funds | STATE Funds | LOCAL Funds | LOCAL DEPOSIT AMOUNT (Required only if State Administered) |
| 8005.26.121 | Current | STP (80%) | \$800,000.00 | \$640,000.00 | \$120,000.00 | \$40,000.00 | \$0.00 |
| | Old | STP (80%) | \$800,000.00 | \$640,000.00 | \$120,000.00 | \$40,000.00 | \$0.00 |
| 8005.26.221 | Current | STP (80%) | \$50,000.00 | \$40,000.00 | \$7,500.00 | \$2,500.00 | \$0.00 |
| | Old | STP (80%) | \$50,000.00 | \$40,000.00 | \$0.00 | \$10,000.00 | \$0.00 |
| 8005.26.321 | Current | STP (80%) | \$4,825,000.00 | \$3,860,000.00 | \$723,750.00 | \$241,250.00 | \$0.00 |
| | Old | | \$ 0.00 | \$0.00 | \$0.00 | \$0.00 | \$0.00 |
| 8005.26.322 | Current | CRP (80%) | \$1,228,000.00 | \$982,400.00 | \$184,200.00 | \$61,400.00 | \$0.00 |
| | Old | | \$ 0.00 | \$0.00 | \$0.00 | \$0.00 | \$0.00 |
| 8005.26.323 | Current | CRP (80%) | \$834,000.00 | \$667,200.00 | \$125,100.00 | \$41,700.00 | \$0.00 |
| | Old | | \$ 0.00 | \$0.00 | \$0.00 | \$0.00 | \$0.00 |
| 8005.26.NPS | Current | 100% Local | \$1,055,600.00 | \$0.00 | \$0.00 | \$1,055,600.00 | \$0.00 |
| | Old | | \$ 0.00 | \$0.00 | \$0.00 | \$0.00 | \$0.00 |
| . . | Current | | \$ 0.00 | \$0.00 | \$0.00 | \$0.00 | \$0.00 |
| | Old | | \$ 0.00 | \$0.00 | \$0.00 | \$0.00 | \$0.00 |
| . . | Current | | \$ 0.00 | \$0.00 | \$0.00 | \$0.00 | \$0.00 |
| | Old | | \$ 0.00 | \$0.00 | \$0.00 | \$0.00 | \$0.00 |
| . . | Current | | \$ 0.00 | \$0.00 | \$0.00 | \$0.00 | \$0.00 |
| | Old | | \$ 0.00 | \$0.00 | \$0.00 | \$0.00 | \$0.00 |
| . . | Current | | \$ 0.00 | \$0.00 | \$0.00 | \$0.00 | \$0.00 |
| | Old | | \$ 0.00 | \$0.00 | \$0.00 | \$0.00 | \$0.00 |
| TOTAL CURRENT COSTS: | | | \$8,792,600.00 | \$6,189,600.00 | \$1,160,550.00 | \$1,442,450.00 | \$ 0.00 |

NYSDOT/State-Local Agreement – Schedule A PIN 8005.26

| | |
|--|---------|
| B. Local Deposit(s) from Section A: | \$ 0.00 |
| Additional Local Deposit(s) | \$0.00 |
| Total Local Deposit(s) | \$ 0.00 |

| C. Total Project Costs <i>All totals will calculate automatically.</i> | | | |
|---|------------------------|---------------------------|------------------------------|
| Total FEDERAL Cost | Total STATE Cost | Total LOCAL Cost | Total ALL SOURCES Cost |
| \$6,189,600.00 | \$1,160,550.00 | \$1,442,450.00 | \$8,792,600.00 |
| | | Total FEDERAL Cost | \$6,189,600.00 |
| | | Total STATE Cost | \$1,160,550.00 |
| SFS TOTAL CONTRACT AMOUNT | | | \$7,350,150.00 |

| | |
|--|--|
| D. Point of Contact for Questions Regarding this Schedule A (Must be completed) | Name: <u>Giselle Conrad</u> Phone No: <u>845-431-5731</u> |
|--|--|

See Agreement (or Supplemental Agreement Cover) for required contract signatures.

Footnotes (FN): (See [LPB's](#) SharePoint for link to sample footnotes)

- Project Description Continued: The project objective is to upgrade sidewalks and curb ramps and replace existing traffic signals along Broadway between Robinson Avenue (Route 9W) and Grand Street to meet Americans with Disabilities Act Accessibility Guidelines (ADAAG). The project will replace six non-standard traffic signals at Broadway intersecting Robinson Avenue, Concord Street/Mill Street, William Street/Dubois Street, Johnston Street, Liberty Street and Grand Street. Sidewalks and curb ramps will be replaced at all curb corners on both sides of Broadway. Sidewalk curb extensions will be implemented to improve pedestrian access and safety throughout the corridor. In total, approximately 5,600 square yards of new sidewalk will be installed. Landscaping and utilities may be upgraded on an as needed basis.
- This Schedule A adds the construction and construction inspection phases and funds.
- xx.NPS represents 100% local overmatch for the construction phase.
-
-
-
-
-
-
-
-

- PIN 8005.26 4/15/2026 GC

APPENDIX A

STANDARD CLAUSES FOR NEW YORK STATE CONTRACTS

**PLEASE RETAIN THIS DOCUMENT
FOR FUTURE REFERENCE.**

TABLE OF CONTENTS

| | Page |
|---|-------------|
| 1. Executory Clause | 3 |
| 2. Non-Assignment Clause | 3 |
| 3. Comptroller's Approval | 3 |
| 4. Workers' Compensation Benefits | 3 |
| 5. Non-Discrimination Requirements | 3 |
| 6. Wage and Hours Provisions | 3-4 |
| 7. Non-Collusive Bidding Certification | 4 |
| 8. International Boycott Prohibition | 4 |
| 9. Set-Off Rights | 4 |
| 10. Records | 4 |
| 11. Identifying Information and Privacy Notification | 4 |
| 12. Equal Employment Opportunities For Minorities and Women | 5 |
| 13. Conflicting Terms | 5 |
| 14. Governing Law | 5 |
| 15. Late Payment | 5 |
| 16. No Arbitration | 5 |
| 17. Service of Process | 5 |
| 18. Prohibition on Purchase of Tropical Hardwoods | 5-6 |
| 19. MacBride Fair Employment Principles | 6 |
| 20. Omnibus Procurement Act of 1992 | 6 |
| 21. Reciprocity and Sanctions Provisions | 6 |
| 22. Compliance with Breach Notification and Data Security Laws | 6 |
| 23. Compliance with Consultant Disclosure Law | 6-7 |
| 24. Procurement Lobbying | 7 |
| 25. Certification of Registration to Collect Sales and Compensating Use Tax by Certain State Contractors, Affiliates and Subcontractors | 7 |
| 26. Iran Divestment Act | 7 |
| 27. Admissibility of Contract | 7 |

STANDARD CLAUSES FOR NYS CONTRACTS

The parties to the attached contract, license, lease, amendment or other agreement of any kind (hereinafter, “the contract” or “this contract”) agree to be bound by the following clauses which are hereby made a part of the contract (the word “Contractor” herein refers to any party other than the State, whether a contractor, licenser, licensee, lessor, lessee or any other party):

1. EXECUTORY CLAUSE. In accordance with Section 41 of the State Finance Law, the State shall have no liability under this contract to the Contractor or to anyone else beyond funds appropriated and available for this contract.

2. NON-ASSIGNMENT CLAUSE. In accordance with Section 138 of the State Finance Law, this contract may not be assigned by the Contractor or its right, title or interest therein assigned, transferred, conveyed, sublet or otherwise disposed of without the State’s previous written consent, and attempts to do so are null and void. Notwithstanding the foregoing, such prior written consent of an assignment of a contract let pursuant to Article XI of the State Finance Law may be waived at the discretion of the contracting agency and with the concurrence of the State Comptroller where the original contract was subject to the State Comptroller’s approval, where the assignment is due to a reorganization, merger or consolidation of the Contractor’s business entity or enterprise. The State retains its right to approve an assignment and to require that any Contractor demonstrate its responsibility to do business with the State. The Contractor may, however, assign its right to receive payments without the State’s prior written consent unless this contract concerns Certificates of Participation pursuant to Article 5-A of the State Finance Law.

3. COMPTROLLER’S APPROVAL. In accordance with Section 112 of the State Finance Law, if this contract exceeds \$50,000 (or \$75,000 for State University of New York or City University of New York contracts for goods, services, construction and printing, and \$150,000 for State University Health Care Facilities) or if this is an amendment for any amount to a contract which, as so amended, exceeds said statutory amount, or if, by this contract, the State agrees to give something other than money when the value or reasonably estimated value of such consideration exceeds \$25,000, it shall not be valid, effective or binding upon the State until it has been approved by the State Comptroller and filed in his office. Comptroller’s approval of contracts let by the Office of General Services, either for itself or its customer agencies by the Office of General Services Business Services Center, is required when such contracts exceed \$85,000. Comptroller’s approval of contracts established as centralized contracts through the Office of General Services is required when such contracts exceed \$125,000, and when a purchase order or other procurement transaction issued under such centralized contract exceeds \$200,000.

4. WORKERS’ COMPENSATION BENEFITS. In accordance with Section 142 of the State Finance Law, this contract shall be void and of no force and effect unless the Contractor shall provide and maintain coverage during the life of this contract for the benefit of such employees as are required to be covered by the provisions of the Workers’ Compensation Law.

5. NON-DISCRIMINATION REQUIREMENTS. To the extent required by Article 15 of the Executive Law (also known as the Human Rights Law) and all other State and Federal statutory and constitutional non-discrimination provisions, the Contractor will not discriminate against any employee or applicant for employment, nor subject any individual to harassment, because of age, race, creed, color, national origin, citizenship or immigration status, sexual orientation, gender identity or expression, military status, sex, disability, predisposing genetic characteristics, familial status, marital status, or domestic violence victim status or because the individual has opposed any practices forbidden under the Human Rights Law or has filed a complaint, testified, or assisted in any proceeding under the Human Rights Law. Furthermore, in accordance with Section 220-e of the Labor Law, if this is a contract for the construction, alteration or repair of any public building or public work or for the manufacture, sale or distribution of materials, equipment or supplies, and to the extent that this contract shall be performed within the State of New York, Contractor agrees that neither it nor its subcontractors shall, by reason of race, creed, color, disability, sex, or national origin: (a) discriminate in hiring against any New York State citizen who is qualified and available to perform the work; or (b) discriminate against or intimidate any employee hired for the performance of work under this contract. If this is a building service contract as defined in Section 230 of the Labor Law, then, in accordance with Section 239 thereof, Contractor agrees that neither it nor its subcontractors shall by reason of race, creed, color, national origin, age, sex or disability: (a) discriminate in hiring against any New York State citizen who is qualified and available to perform the work; or (b) discriminate against or intimidate any employee hired for the performance of work under this contract. Contractor is subject to fines of \$50.00 per person per day for any violation of Section 220-e or Section 239 as well as possible termination of this contract and forfeiture of all moneys due hereunder for a second or subsequent violation.

6. WAGE AND HOURS PROVISIONS. If this is a public work contract covered by Article 8 of the Labor Law or a building service contract covered by Article 9 thereof, neither Contractor’s employees nor the employees of its subcontractors may be required or permitted to work more than the number of hours or days stated in said statutes, except as otherwise provided in the Labor Law and as set forth in prevailing wage and supplement schedules issued by the State Labor Department. Furthermore, Contractor and its subcontractors must pay at least the prevailing wage rate and pay or provide the prevailing supplements, including the premium rates for overtime pay, as determined by the State Labor Department in

accordance with the Labor Law. Additionally, effective April 28, 2008, if this is a public work contract covered by Article 8 of the Labor Law, the Contractor understands and agrees that the filing of payrolls in a manner consistent with Subdivision 3-a of Section 220 of the Labor Law shall be a condition precedent to payment by the State of any State approved sums due and owing for work done upon the project.

7. NON-COLLUSIVE BIDDING CERTIFICATION. In accordance with Section 139-d of the State Finance Law, if this contract was awarded based upon the submission of bids, Contractor affirms, under penalty of perjury, that its bid was arrived at independently and without collusion aimed at restricting competition. Contractor further affirms that, at the time Contractor submitted its bid, an authorized and responsible person executed and delivered to the State a non-collusive bidding certification on Contractor's behalf.

8. INTERNATIONAL BOYCOTT PROHIBITION. In accordance with Section 220-f of the Labor Law and Section 139-h of the State Finance Law, if this contract exceeds \$5,000, the Contractor agrees, as a material condition of the contract, that neither the Contractor nor any substantially owned or affiliated person, firm, partnership or corporation has participated, is participating, or shall participate in an international boycott in violation of the federal Export Administration Act of 1979 (50 USC App. Sections 2401 et seq.) or regulations thereunder. If such Contractor, or any of the aforesaid affiliates of Contractor, is convicted or is otherwise found to have violated said laws or regulations upon the final determination of the United States Commerce Department or any other appropriate agency of the United States subsequent to the contract's execution, such contract, amendment or modification thereto shall be rendered forfeit and void. The Contractor shall so notify the State Comptroller within five (5) business days of such conviction, determination or disposition of appeal (2 NYCRR § 105.4).

9. SET-OFF RIGHTS. The State shall have all of its common law, equitable and statutory rights of set-off. These rights shall include, but not be limited to, the State's option to withhold for the purposes of set-off any moneys due to the Contractor under this contract up to any amounts due and owing to the State with regard to this contract, any other contract with any State department or agency, including any contract for a term commencing prior to the term of this contract, plus any amounts due and owing to the State for any other reason including, without limitation, tax delinquencies, fee delinquencies or monetary penalties relative thereto. The State shall exercise its set-off rights in accordance with normal State practices including, in cases of set-off pursuant to an audit, the finalization of such audit by the State agency, its representatives, or the State Comptroller.

10. RECORDS. The Contractor shall establish and maintain complete and accurate books, records, documents, accounts and other evidence directly pertinent to performance under this contract (hereinafter, collectively, the "Records"). The Records

must be kept for the balance of the calendar year in which they were made and for six (6) additional years thereafter. The State Comptroller, the Attorney General and any other person or entity authorized to conduct an examination, as well as the agency or agencies involved in this contract, shall have access to the Records during normal business hours at an office of the Contractor within the State of New York or, if no such office is available, at a mutually agreeable and reasonable venue within the State, for the term specified above for the purposes of inspection, auditing and copying. The State shall take reasonable steps to protect from public disclosure any of the Records which are exempt from disclosure under Section 87 of the Public Officers Law (the "Statute") provided that: (i) the Contractor shall timely inform an appropriate State official, in writing, that said records should not be disclosed; and (ii) said records shall be sufficiently identified; and (iii) designation of said records as exempt under the Statute is reasonable. Nothing contained herein shall diminish, or in any way adversely affect, the State's right to discovery in any pending or future litigation.

11. IDENTIFYING INFORMATION AND PRIVACY NOTIFICATION. (a) Identification Number(s). Every invoice or New York State Claim for Payment submitted to a New York State agency by a payee, for payment for the sale of goods or services or for transactions (e.g., leases, easements, licenses, etc.) related to real or personal property must include the payee's identification number. The number is any or all of the following: (i) the payee's Federal employer identification number, (ii) the payee's Federal social security number, and/or (iii) the payee's Vendor Identification Number assigned by the Statewide Financial System. Failure to include such number or numbers may delay payment. Where the payee does not have such number or numbers, the payee, on its invoice or Claim for Payment, must give the reason or reasons why the payee does not have such number or numbers.

(b) Privacy Notification. (1) The authority to request the above personal information from a seller of goods or services or a lessor of real or personal property, and the authority to maintain such information, is found in Section 5 of the State Tax Law. Disclosure of this information by the seller or lessor to the State is mandatory. The principal purpose for which the information is collected is to enable the State to identify individuals, businesses and others who have been delinquent in filing tax returns or may have understated their tax liabilities and to generally identify persons affected by the taxes administered by the Commissioner of Taxation and Finance. The information will be used for tax administration purposes and for any other purpose authorized by law. (2) The personal information is requested by the purchasing unit of the agency contracting to purchase the goods or services or lease the real or personal property covered by this contract or lease. The information is maintained in the Statewide Financial System by the Vendor Management Unit within the Bureau of State Expenditures, Office of the State Comptroller, 110 State Street, Albany, New York 12236.

12. EQUAL EMPLOYMENT OPPORTUNITIES FOR MINORITIES AND WOMEN.

In accordance with Section 312 of the Executive Law and 5 NYCRR Part 143, if this contract is: (i) a written agreement or purchase order instrument, providing for a total expenditure in excess of \$25,000.00, whereby a contracting agency is committed to expend or does expend funds in return for labor, services, supplies, equipment, materials or any combination of the foregoing, to be performed for, or rendered or furnished to the contracting agency; or (ii) a written agreement in excess of \$100,000.00 whereby a contracting agency is committed to expend or does expend funds for the acquisition, construction, demolition, replacement, major repair or renovation of real property and improvements thereon; or (iii) a written agreement in excess of \$100,000.00 whereby the owner of a State assisted housing project is committed to expend or does expend funds for the acquisition, construction, demolition, replacement, major repair or renovation of real property and improvements thereon for such project, then the following shall apply and by signing this agreement the Contractor certifies and affirms that it is Contractor's equal employment opportunity policy that:

(a) The Contractor will not discriminate against employees or applicants for employment because of race, creed, color, national origin, sex, age, disability or marital status, shall make and document its conscientious and active efforts to employ and utilize minority group members and women in its work force on State contracts and will undertake or continue existing programs of affirmative action to ensure that minority group members and women are afforded equal employment opportunities without discrimination. Affirmative action shall mean recruitment, employment, job assignment, promotion, upgradings, demotion, transfer, layoff, or termination and rates of pay or other forms of compensation;

(b) at the request of the contracting agency, the Contractor shall request each employment agency, labor union, or authorized representative of workers with which it has a collective bargaining or other agreement or understanding, to furnish a written statement that such employment agency, labor union or representative will not discriminate on the basis of race, creed, color, national origin, sex, age, disability or marital status and that such union or representative will affirmatively cooperate in the implementation of the Contractor's obligations herein; and

(c) the Contractor shall state, in all solicitations or advertisements for employees, that, in the performance of the State contract, all qualified applicants will be afforded equal employment opportunities without discrimination because of race, creed, color, national origin, sex, age, disability or marital status.

Contractor will include the provisions of "(a), (b) and (c)" above, in every subcontract over \$25,000.00 for the construction, demolition, replacement, major repair, renovation, planning or design of real property and improvements thereon (the "Work") except where the Work is for the beneficial use of the Contractor. Section 312 does not

apply to: (i) work, goods or services unrelated to this contract; or (ii) employment outside New York State. The State shall consider compliance by a contractor or subcontractor with the requirements of any federal law concerning equal employment opportunity which effectuates the purpose of this clause. The contracting agency shall determine whether the imposition of the requirements of the provisions hereof duplicate or conflict with any such federal law and if such duplication or conflict exists, the contracting agency shall waive the applicability of Section 312 to the extent of such duplication or conflict. Contractor will comply with all duly promulgated and lawful rules and regulations of the Department of Economic Development's Division of Minority and Women's Business Development pertaining hereto.

13. CONFLICTING TERMS. In the event of a conflict between the terms of the contract (including any and all attachments thereto and amendments thereof) and the terms of this Appendix A, the terms of this Appendix A shall control.

14. GOVERNING LAW. This contract shall be governed by the laws of the State of New York except where the Federal supremacy clause requires otherwise.

15. LATE PAYMENT. Timeliness of payment and any interest to be paid to Contractor for late payment shall be governed by Article 11-A of the State Finance Law to the extent required by law.

16. NO ARBITRATION. Disputes involving this contract, including the breach or alleged breach thereof, may not be submitted to binding arbitration (except where statutorily authorized), but must, instead, be heard in a court of competent jurisdiction of the State of New York.

17. SERVICE OF PROCESS. In addition to the methods of service allowed by the State Civil Practice Law & Rules ("CPLR"), Contractor hereby consents to service of process upon it by registered or certified mail, return receipt requested. Service hereunder shall be complete upon Contractor's actual receipt of process or upon the State's receipt of the return thereof by the United States Postal Service as refused or undeliverable. Contractor must promptly notify the State, in writing, of each and every change of address to which service of process can be made. Service by the State to the last known address shall be sufficient. Contractor will have thirty (30) calendar days after service hereunder is complete in which to respond.

18. PROHIBITION ON PURCHASE OF TROPICAL HARDWOODS. The Contractor certifies and warrants that all wood products to be used under this contract award will be in accordance with, but not limited to, the specifications and provisions of Section 165 of the State Finance Law, (Use of Tropical Hardwoods) which prohibits purchase and use of tropical hardwoods, unless specifically exempted, by the State or any governmental agency or political subdivision or public benefit corporation. Qualification for an exemption under this

law will be the responsibility of the contractor to establish to meet with the approval of the State.

In addition, when any portion of this contract involving the use of woods, whether supply or installation, is to be performed by any subcontractor, the prime Contractor will indicate and certify in the submitted bid proposal that the subcontractor has been informed and is in compliance with specifications and provisions regarding use of tropical hardwoods as detailed in § 165 State Finance Law. Any such use must meet with the approval of the State; otherwise, the bid may not be considered responsive. Under bidder certifications, proof of qualification for exemption will be the responsibility of the Contractor to meet with the approval of the State.

19. MACBRIDE FAIR EMPLOYMENT PRINCIPLES (APPLICABLE ONLY IN NON-FEDERAL AID NEW YORK STATE CONTRACTS). In accordance with the MacBride Fair Employment Principles (Chapter 807 of the Laws of 1992), the Contractor hereby stipulates that the Contractor either (a) has no business operations in Northern Ireland, or (b) shall take lawful steps in good faith to conduct any business operations in Northern Ireland in accordance with the MacBride Fair Employment Principles (as described in Section 165 of the New York State Finance Law), and shall permit independent monitoring of compliance with such principles.

20. OMNIBUS PROCUREMENT ACT OF 1992 (APPLICABLE ONLY IN NON-FEDERAL AID NEW YORK STATE CONTRACTS). It is the policy of New York State to maximize opportunities for the participation of New York State business enterprises, including minority- and women-owned business enterprises as bidders, subcontractors and suppliers on its procurement contracts.

Information on the availability of New York State subcontractors and suppliers is available from:

NYS Department of Economic Development
Division for Small Business and Technology Development
625 Broadway
Albany, New York 12245
Telephone: 518-292-5100

A directory of certified minority- and women-owned business enterprises is available from:

NYS Department of Economic Development
Division of Minority and Women's Business Development
633 Third Avenue 33rd Floor
New York, NY 10017
646-846-7364
email: mwbebusinessdev@esd.ny.gov
<https://ny.newnycontracts.com/FrontEnd/searchcertifieddirectory.asp>

The Omnibus Procurement Act of 1992 (Chapter 844 of the Laws of 1992, codified in State Finance Law § 139-i and Public

Authorities Law § 2879(3)(n)-(p)) requires that by signing this bid proposal or contract, as applicable, Contractors certify that whenever the total bid amount is greater than \$1 million:

(a) The Contractor has made reasonable efforts to encourage the participation of New York State Business Enterprises as suppliers and subcontractors, including certified minority- and women-owned business enterprises, on this project, and has retained the documentation of these efforts to be provided upon request to the State;

(b) The Contractor has complied with the Federal Equal Opportunity Act of 1972 (P.L. 92-261), as amended;

(c) The Contractor agrees to make reasonable efforts to provide notification to New York State residents of employment opportunities on this project through listing any such positions with the Job Service Division of the New York State Department of Labor, or providing such notification in such manner as is consistent with existing collective bargaining contracts or agreements. The Contractor agrees to document these efforts and to provide said documentation to the State upon request; and

(d) The Contractor acknowledges notice that the State may seek to obtain offset credits from foreign countries as a result of this contract and agrees to cooperate with the State in these efforts.

21. RECIPROCITY AND SANCTIONS PROVISIONS. Bidders are hereby notified that if their principal place of business is located in a country, nation, province, state or political subdivision that penalizes New York State vendors, and if the goods or services they offer will be substantially produced or performed outside New York State, the Omnibus Procurement Act 1994 and 2000 amendments (Chapter 684 and Chapter 383, respectively, codified in State Finance Law § 165(6) and Public Authorities Law § 2879(5)) require that they be denied contracts which they would otherwise obtain. NOTE: As of May 2023, the list of discriminatory jurisdictions subject to this provision includes the states of South Carolina, Alaska, West Virginia, Wyoming, Louisiana and Hawaii.

22. COMPLIANCE WITH BREACH NOTIFICATION AND DATA SECURITY LAWS. Contractor shall comply with the provisions of the New York State Information Security Breach and Notification Act (General Business Law §§ 899-aa and 899-bb and State Technology Law § 208).

23. COMPLIANCE WITH CONSULTANT DISCLOSURE LAW. If this is a contract for consulting services, defined for purposes of this requirement to include analysis, evaluation, research, training, data processing, computer programming, engineering, environmental, health, and mental health services, accounting, auditing, paralegal, legal or similar services, then, in accordance with Section 163 (4)(g) of the State Finance Law (as amended by Chapter 10 of the Laws of 2006), the Contractor shall timely, accurately and properly comply with the requirement to submit an annual

employment report for the contract to the agency that awarded the contract, the Department of Civil Service and the State Comptroller.

24. PROCUREMENT LOBBYING. To the extent this agreement is a “procurement contract” as defined by State Finance Law §§ 139-j and 139-k, by signing this agreement the contractor certifies and affirms that all disclosures made in accordance with State Finance Law §§ 139-j and 139-k are complete, true and accurate. In the event such certification is found to be intentionally false or intentionally incomplete, the State may terminate the agreement by providing written notification to the Contractor in accordance with the terms of the agreement.

25. CERTIFICATION OF REGISTRATION TO COLLECT SALES AND COMPENSATING USE TAX BY CERTAIN STATE CONTRACTORS, AFFILIATES AND SUBCONTRACTORS.

To the extent this agreement is a contract as defined by Tax Law § 5-a, if the contractor fails to make the certification required by Tax Law § 5-a or if during the term of the contract, the Department of Taxation and Finance or the covered agency, as defined by Tax Law § 5-a, discovers that the certification, made under penalty of perjury, is false, then such failure to file or false certification shall be a material breach of this contract and this contract may be terminated, by providing written notification to the Contractor in accordance with the terms of the agreement, if the covered agency determines that such action is in the best interest of the State.

26. IRAN DIVESTMENT ACT. By entering into this Agreement, Contractor certifies in accordance with State Finance Law § 165-a that it is not on the “Entities Determined to be Non-Responsive Bidders/Offerers pursuant to the New York State Iran Divestment Act of 2012” (“Prohibited Entities List”) posted at: <https://ogs.ny.gov/iran-divestment-act-2012>

Contractor further certifies that it will not utilize on this Contract any subcontractor that is identified on the Prohibited Entities List. Contractor agrees that should it seek to renew or extend this Contract, it must provide the same certification at the time the Contract is renewed or extended. Contractor also agrees that any proposed Assignee of this Contract will be required to certify that it is not on the Prohibited Entities List before the contract assignment will be approved by the State.

During the term of the Contract, should the state agency receive information that a person (as defined in State Finance Law § 165-a) is in violation of the above-referenced certifications, the state agency will review such information and offer the person an opportunity to respond. If the person fails to demonstrate that it has ceased its engagement in the investment activity which is in violation of the Act within 90 days after the determination of such violation, then the state agency shall take such action as may be appropriate and provided for by law, rule, or contract, including, but not limited to, imposing sanctions,

seeking compliance, recovering damages, or declaring the Contractor in default.

The state agency reserves the right to reject any bid, request for assignment, renewal or extension for an entity that appears on the Prohibited Entities List prior to the award, assignment, renewal or extension of a contract, and to pursue a responsibility review with respect to any entity that is awarded a contract and appears on the Prohibited Entities list after contract award.

27. ADMISSIBILITY OF REPRODUCTION OF CONTRACT. Notwithstanding the best evidence rule or any other legal principle or rule of evidence to the contrary, the Contractor acknowledges and agrees that it waives any and all objections to the admissibility into evidence at any court proceeding or to the use at any examination before trial of an electronic reproduction of this contract, in the form approved by the State Comptroller, if such approval was required, regardless of whether the original of said contract is in existence.

SAMPLE RESOLUTION BY MUNICIPALITY
(Locally Administered Project)
RESOLUTION NUMBER: _____

Authorizing the implementation, and funding in the first instance 100% of the federal-aid and State "Marchiselli" Program-aid eligible costs, of a transportation federal-aid project, and appropriating funds therefore.

WHEREAS, a Project for the Broadway Pedestrian and Traffic Signal Improvements in the City of Newburgh, PIN 8005.26 (the "Project") is eligible for funding under Title 23 U.S. Code, as amended, that calls for the apportionment of the costs such program to be borne at the ratio of 80% Federal funds and 20% non-federal funds; and

WHEREAS, the City of Newburgh desires to advance the Project by making a commitment of 100% of the non-federal share of the costs of construction and construction inspection.

NOW, THEREFORE, the Newburgh City Council, duly convened does hereby

RESOLVE, that the Newburgh City Council hereby approves the above-subject project; and it is hereby further

RESOLVED, that the Newburgh City Council hereby authorizes the City of Newburgh to pay in the first instance 100% of the federal and non-federal share of the cost of construction and construction inspection work for the Project or portions thereof; and it is further

RESOLVED, that the sum of **\$7,942,600 (\$8,792,600 minus the previous \$850,000)** is hereby appropriated from _____ [or, appropriated pursuant to _____] and made available to cover the cost of participation in the above phase of the Project; and it is further

RESOLVED, that in the event the full federal and non-federal share costs of the project exceeds the amount appropriated above, the Newburgh City Council shall convene as soon as possible to appropriate said excess amount immediately upon the notification by the City Manager thereof, and it is further

RESOLVED, that the City Manager of the City of Newburgh be and is hereby authorized to execute all necessary Agreements, certifications or reimbursement requests for Federal Aid and/or applicable Marchiselli Aid on behalf of the City of Newburgh with the New York State Department of Transportation in connection with the advancement or approval of the Project and providing for the administration of the Project and the municipality's first instance funding of project costs and permanent funding of the local share of federal-aid and state-aid eligible Project costs and all Project costs within appropriations therefore that are not so eligible, and it is further

RESOLUTION NO.: _____-2026

OF

MAY 11, 2026

**A RESOLUTION AMENDING THE 2026 PERSONNEL ANALYSIS BOOK
TO ADD ONE TEMPORARY PART-TIME PURCHASING AGENT
IN THE FINANCE DEPARTMENT**

WHEREAS, due to a retirement, the City Manager proposes to add one Purchasing Agent position in a temporary part-time capacity in the Finance Department; and

WHEREAS, the City Council has determined that adding one Purchasing Agent position in a temporary part-time capacity in the Finance Department will promote economy and efficiency within the Department; the same being in the best interests of the City of Newburgh;

NOW, THEREFORE, BE IT RESOLVED, by the Council of the City of Newburgh, New York that the Personnel Analysis Book for the fiscal year 2026 be amended to add one Purchasing Agent position in a temporary part-time capacity in the Finance Department.

RESOLUTION NO.: _____ - 2026

OF

MAY 11, 2026

**A RESOLUTION AUTHORIZING THE CITY MANAGER TO APPLY FOR
AND ACCEPT IF AWARDED A NEW YORK STATE
ENVIRONMENTAL FACILITIES CORPORATION
STRENGTHENING ESSENTIAL CYBERSECURITY FOR UTILITIES
AND RESILIENCY ENHANCEMENT (SECURE) ASSESSMENT PROGRAM GRANT
IN THE AMOUNT OF \$50,000.00 WITH NO CITY MATCH**

WHEREAS, the New York State Environmental Facilities Corporation is soliciting applications for funding under its Strengthening Essential Cybersecurity for Utilities and Resiliency Enhancement (SECURE) Program for eligible applicants to support cybersecurity assessments that safeguard essential services and improve risk management practices to ensure operational continuity in water and wastewater systems in New York State; and

WHEREAS, the City of Newburgh is an eligible applicant and proposes to apply for grant funding in the amount of \$50,000.00 to conduct a cybersecurity assessment of its municipal water and wastewater systems to address new cybersecurity compliance requirements; and

WHEREAS, this Council has determined that applying for and accepting if awarded said grant is in the best interest of the City of Newburgh and its further development;

NOW, THEREFORE, BE IT RESOLVED, by the Council of the City of Newburgh, New York that the City Manager be and he is hereby authorized to apply for and accept if awarded a New York State Environmental Facilities Corporation Strengthening Essential Cybersecurity for Utilities and Resiliency Enhancement (SECURE) Program grant in the amount of \$50,000.00 with no City match to conduct a cybersecurity assessment of its water and wastewater systems; and to execute all such further contracts and documentation and take such further actions as may be appropriate and necessary to accept such grant and administer the program funded thereby.



City of Newburgh

GRANT APPLICATION FORM

Grant Requestor:

Please complete the following form and submit the form along with either a hard copy of the grant announcement or the grant announcement website address to the City of Newburgh Grants Administrator for processing. You will be notified when your grant request has been approved to be sent for City Council Resolution.

NOTE: All fields are required unless marked "OPTIONAL."

SECTION A. COMPLETED BY GRANT REQUESTOR

| | | |
|--|---|---|
| NAME OF PROJECT FOR GRANT: City of Newburgh Cybersecurity Upgrade | NAME OF DEPARTMENT REQUESTING GRANT: IT Department | NAME OF DEPARTMENT HEAD/SPONSOR AUTHORIZING GRANT: Camile Mohammed |
| NAME OF GRANT/NAME OF AWARING AGENCY: EFC SECURE Assessment Grant | GRANT SUBMITTAL DATE: 5/15/2026 | AMOUNT OF AWARD: \$50,000 |
| MATCH REQUIRED? IF YES, AMOUNT AND TYPE: (EX. CASH, IN-KIND) No | AMOUNT REQUIRED BY THE CITY OF NEWBURGH: -0- | (OPTIONAL) ANY ADDITIONAL GRANT CONDITIONS: |

PROJECT PLAN: City of Newburgh Water Cybersecurity Upgrade

Scope of Project: **The SECURE Assessment grant will assist eligible clean water and drinking water systems to evaluate their cybersecurity posture, identify vulnerabilities, and prioritize risk mitigation needs. To become compliant with the NYS DEC regulations**



Key Stakeholders: Water, IT, EO

Project Timeline: (ex. Dates):



City of Newburgh

GRANT APPLICATION FORM

| |
|---|
| SECTION B. FOR REVIEW BY CITY COMPTROLLER |
| GRANT MATCH REQUIREMENT REVIEWED? YES/NO: |
| COMMENTS: |
| IN-KIND SERVICES REQUIREMENT REVIEWED? YES/NO |
| COMMENTS: |
| STAFFING ISSUES REVIEWED? YES/NO: |
| COMMENTS: |
| ANY ADDITIONAL COMMENTS: |
| → APPROVED BY CITY COMPTROLLER? <input checked="" type="radio"/> YES / <input type="radio"/> NO |
| CITY COMPTROLLER SIGNATURE: <u></u> |
| DATE: <u>5/4/2026</u> |
| NOTE: IF GRANT APPROVED, CITY COMPTROLLER WILL FORWARD TO CITY MANAGER FOR REVIEW. IF GRANT NOT APPROVED, CITY COMPTROLLER TO RETURN TO GRANTS ADMINISTRATOR FOR FURTHER REVIEW BY PROJECT SPONSOR. |
| SECTION D: FOR REVIEW BY CORPORATION COUNSEL |
| → APPROVED BY CORPORATION COUNSEL FOR RESOLUTION? <input checked="" type="radio"/> YES / <input type="radio"/> NO |
| CORPORATION COUNSEL SIGNATURE: <u></u> |
| DATE: <u>5/4/2026</u> |
| DATE RESOLUTION TO BE SENT TO CITY COUNCIL MEETING: <u>5/7/26 w.s. after council meeting</u> |



City of Newburgh

GRANT APPLICATION FORM

| |
|--|
| |
| SECTION C: FOR REVIEW BY CITY MANAGER |
| → APPROVED BY CITY MANAGER? YES/NO |
| CITY MANAGER SIGNATURE: _____ |
| DATE: <u>5-4-26</u> |

GRANT SUMMARY

Strengthening Essential Cybersecurity for Utilities and Resiliency Enhancement (SECURE) Program

OVERVIEW

The New York State Environmental Facilities Corporation (EFC) is offering \$2.5 million dollars to strengthen cybersecurity readiness and resilience and support operational continuity for eligible water and wastewater systems across New York State. The SECURE program will provide funding for projects that enhance cyber protections, modernize digital infrastructure and reduce vulnerabilities for critical drinking water and wastewater systems. This strategic initiative expands upon Governor Hochul's commitment to safeguard essential services, improve risk management practices, and support communities meeting evolving cybersecurity expectations. Funding is available for both cybersecurity assessments and implementation based on best practices and regulatory requirements. Based on the grant criteria for each program EFC will evaluate all project applications received by the due date of **May 15, 2026**. Information provided with the application will not be shared with third parties.

SECURE Assessment Grant

The SECURE Assessment grant will assist eligible clean water and drinking water systems to evaluate their cybersecurity posture, identify vulnerabilities, and prioritize risk mitigation needs. A municipality may apply for up to \$50,000 with a 0% match.

Objectives:

- Assess system risks and vulnerabilities in accordance with NIST Cybersecurity Framework (NIST CSF) 2.0 and the NIST Guide to Operational Technology (OT) Security
- Evaluate vulnerabilities of industrial control systems (ICS), operational technologies (OT) and supervisory control and data control and data acquisition (SCADA) systems and define mitigation priorities.
- Develop and/or validate OT Asset Inventory by identifying and documenting all in-scope OT assets.
- Determine any gaps in Confidentiality, Integrity, and Availability (CIA) protections.
- Conduct a training and workforce needs assessment to identify operator training gaps and required cybersecurity competencies.
- Develop new or review existing cybersecurity policies, procedures and roles, including inventory ownership and updating processes taken.
- Conduct readiness reviews for compliance with relevant DEC, DOH, and DPS regulations.

Eligible Activities:

- Third-party cybersecurity risk assessments and penetration testing
- Network architecture reviews and asset inventories
- Creation of system-specific cybersecurity implementation roadmaps

Expected Deliverables:

- A written cybersecurity risk assessment report aligned with NIST Cybersecurity Framework (NIST CSF) 2.0
- A list of prioritized vulnerabilities and remediation or mitigation strategies
- A report identifying needs and next steps to comply with relevant DEC, DOH, and DPS regulations

SECURE Implementation Grant

The SECURE Implementation Grant will fund deployment and enhancement of cybersecurity controls, technologies, and response capabilities identified during the assessment phase. The funded activities will be in response to a submitted cybersecurity assessment of the system. Completion of a prior assessment using a SECURE Assessment Grant is not required to apply; however a comparable assessment of the system's cybersecurity needs must have been completed prior to applying for a SECURE Implementation Grant. A municipality may apply for up to 20% of net eligible costs, up to \$100,000.

Objectives:

- Implement technical and administrative controls to protect system CIA.
- Strengthen resilience and incident response capabilities for IT, OT, ICS and SCADA systems.
- Establish and maintain ongoing cybersecurity governance, monitoring, and maintenance processes.

Eligible Activities:

- Procurement and installation of security equipment (firewalls, network segmentation devices, access control systems, etc.).
- Development and implementation of Incident Response Plans (IRPs) and Continuity of Operations Plans (COOPs).
- Deployment of monitoring, alerting, and backup/recovery solutions.

Subscription-based software products **are not eligible** under this program.

Expected Deliverables:

- Demonstrated progress toward compliance with DEC/DOH/DPS regulations.
- Functional Incident Response and Continuity Plan in accordance with NIST Cybersecurity Framework (NIST CSF) 2.0
- Documented evidence of implemented controls.
- Updated cybersecurity policies and standard operating procedures.

ELIGIBILITY REQUIREMENTS

SECURE grants will be awarded to municipalities, defined as a county, city, town, village, district corporation, county or town improvement district, school district, Indian nation or tribe recognized by the state or the United States with a reservation wholly or partly within the boundaries of New York State, any public benefit corporation or public authority established pursuant to the laws of New York or any agency of the State that is empowered to construct and operate a water quality infrastructure project.

APPLICATIONS

Applicants who would like to be considered for a SECURE Assessment or Implementation grant must submit a grant application to EFC no later than 5:00 p.m., on **May 15, 2026**. Information provided with the application will not be shared with third parties.

Applicants who would like to be considered for a SECURE Implementation grant must submit the additional documentation listed below as part of their application:

- Cybersecurity assessment of system addressing:
 - System risks and vulnerabilities in accordance with NIST Cybersecurity Framework (NIST CSF) 2.0.
 - Exposure of ICS/OT and SCADA systems and define mitigation priorities.
 - Gaps in CIA protection.
 - Compliance readiness report identifying needs and next steps to comply with relevant DEC, DOH, and DPS regulations.

Applications must be submitted using the online Application Form located on EFC's Portal at <https://portal.efc.ny.gov>. Applications that are submitted without all required information and documentation will be deemed incomplete and will not be processed.

CONTACT US

Please direct all questions about the SECURE grant program and application to:

Máire Cunningham
New York State Environmental Facilities Corporation
625 Broadway
Albany, New York 12207-2997
Phone: (518) 402-6924
E-mail: SECURE@efc.ny.gov

GRANT SUMMARY

Strengthening Essential Cybersecurity for Utilities and Resiliency Enhancement (SECURE) Program

OVERVIEW

The New York State Environmental Facilities Corporation (EFC) is offering \$2.5 million dollars to strengthen cybersecurity readiness and resilience and support operational continuity for eligible water and wastewater systems across New York State. The SECURE program will provide funding for projects that enhance cyber protections, modernize digital infrastructure and reduce vulnerabilities for critical drinking water and wastewater systems. This strategic initiative expands upon Governor Hochul's commitment to safeguard essential services, improve risk management practices, and support communities meeting evolving cybersecurity expectations. Funding is available for both cybersecurity assessments and implementation based on best practices and regulatory requirements. Based on the grant criteria for each program EFC will evaluate all project applications received by the due date of **May 15, 2026**. Information provided with the application will not be shared with third parties.

SECURE Assessment Grant

The SECURE Assessment grant will assist eligible clean water and drinking water systems to evaluate their cybersecurity posture, identify vulnerabilities, and prioritize risk mitigation needs. A municipality may apply for up to \$50,000 with a 0% match.

Objectives:

- Assess system risks and vulnerabilities in accordance with [NIST Cybersecurity Framework \(NIST CSF\) 2.0](#) and the [NIST Guide to Operational Technology \(OT\) Security](#)
- Evaluate vulnerabilities of industrial control systems (ICS), operational technologies (OT) and supervisory control and data control and data acquisition (SCADA) systems and define mitigation priorities.
- Develop and/or validate OT Asset Inventory by identifying and documenting all in-scope OT assets.
- Determine any gaps in Confidentiality, Integrity, and Availability (CIA) protections.
- Conduct a training and workforce needs assessment to identify operator training gaps and required cybersecurity competencies.
- Develop new or review existing cybersecurity policies, procedures and roles, including inventory ownership and updating processes taken.
- Conduct readiness reviews for compliance with relevant DEC, DOH, and DPS regulations.

Eligible Activities:

- Third-party cybersecurity risk assessments and penetration testing
- Network architecture reviews and asset inventories
- Creation of system-specific cybersecurity implementation roadmaps

Expected Deliverables:

- A written cybersecurity risk assessment report aligned with NIST Cybersecurity Framework (NIST CSF) 2.0
- A list of prioritized vulnerabilities and remediation or mitigation strategies
- A report identifying needs and next steps to comply with relevant DEC, DOH, and DPS regulations

SECURE Implementation Grant

The SECURE Implementation Grant will fund deployment and enhancement of cybersecurity controls, technologies, and response capabilities identified during the assessment phase. The funded activities will be in response to a submitted cybersecurity assessment of the system. Completion of a prior assessment using a SECURE Assessment Grant is not required to apply; however a comparable assessment of the system's cybersecurity needs must have been completed prior to applying for a SECURE Implementation Grant. A municipality may apply for up to 20% of net eligible costs, up to \$100,000.

Objectives:

- Implement technical and administrative controls to protect system CIA.
- Strengthen resilience and incident response capabilities for IT, OT, ICS and SCADA systems.
- Establish and maintain ongoing cybersecurity governance, monitoring, and maintenance processes.

Eligible Activities:

- Procurement and installation of security equipment (firewalls, network segmentation devices, access control systems, etc.).
- Development and implementation of Incident Response Plans (IRPs) and Continuity of Operations Plans (COOPs).
- Deployment of monitoring, alerting, and backup/recovery solutions.

Subscription-based software products **are not eligible** under this program.

Expected Deliverables:

- Demonstrated progress toward compliance with DEC/DOH/DPS regulations.
- Functional Incident Response and Continuity Plan in accordance with NIST Cybersecurity Framework (NIST CSF) 2.0
- Documented evidence of implemented controls.
- Updated cybersecurity policies and standard operating procedures.

ELIGIBILITY REQUIREMENTS

SECURE grants will be awarded to municipalities, defined as a county, city, town, village, district corporation, county or town improvement district, school district, Indian nation or tribe recognized by the state or the United States with a reservation wholly or partly within the boundaries of New York State, any public benefit corporation or public authority established pursuant to the laws of New York or any agency of the State that is empowered to construct and operate a water quality infrastructure project.

APPLICATIONS

Applicants who would like to be considered for a SECURE Assessment or Implementation grant must submit a grant application to EFC no later than 5:00 p.m., on **May 15, 2026**. Information provided with the application will not be shared with third parties.

Applicants who would like to be considered for a SECURE Implementation grant must submit the additional documentation listed below as part of their application:

- Cybersecurity assessment of system addressing:
 - System risks and vulnerabilities in accordance with NIST Cybersecurity Framework (NIST CSF) 2.0.
 - Exposure of ICS/OT and SCADA systems and define mitigation priorities.
 - Gaps in CIA protection.
 - Compliance readiness report identifying needs and next steps to comply with relevant DEC, DOH, and DPS regulations.

Applications must be submitted using the online Application Form located on EFC's Portal at <https://portal.efc.ny.gov>. Applications that are submitted without all required information and documentation will be deemed incomplete and will not be processed.

CONTACT US

Please direct all questions about the SECURE grant program and application to:

Máire Cunningham
New York State Environmental Facilities Corporation
625 Broadway
Albany, New York 12207-2997
Phone: (518) 402-6924
E-mail: SECURE@efc.ny.gov

RESOLUTION NO.: 80 - 2026

OF

APRIL 27, 2026

**A RESOLUTION AUTHORIZING THE CITY MANAGER TO EXECUTE
A SECOND AMENDMENT TO A SITE DEVELOPMENT AGREEMENT WITH
THE KEARNEY REALTY & DEVELOPMENT GROUP INC. FOR THE TRANSFER
AND REDEVELOPMENT OF PROPERTIES LOCATED AT
137 SMITH STREET (SECTION 12, BLOCK 4, LOT 4.1),
140 MONTGOMERY STREET (SECTION 12, BLOCK 4, LOT 10), AND
146 MONTGOMERY STREET (SECTION 12, BLOCK 4, LOT 2.1)**

WHEREAS, by Resolution No. 249-2022, the City of Newburgh authorized execution of a Site Development Agreement (“Agreement”) with The Kearney Realty & Development Group Inc. for the transfer and redevelopment of properties located at 137 Smith Street (Section 12, Block 4, Lot 4.1), 140 Montgomery Street (Section 12, Block 4, Lot 10), and 146 Montgomery Street (Section 12, Block 4, Lot 2.1); and

WHEREAS, by Resolution 199-2025, the City of Newburgh authorized an amendment to the Agreement extending key performance dates; and

WHEREAS, after completing certain site investigation work and other work related to the redevelopment project, The Kearney Realty & Development Group Inc. has proposed certain changes to project representations as set forth in Schedule E of the Agreement; and

WHEREAS, the City Council of the City of Newburgh finds that approving an amendment to the Site Development Agreement that modifies Schedule E of the Agreement is in the best interests of the City of Newburgh;

NOW, THEREFORE, BE IT RESOLVED, by the Council of the City of Newburgh, New York that the City Manager be and he is hereby authorized to enter into the attached Amendment (amending Schedule E) to the Site Development Agreement with The Kearney Realty & Development Group Inc. for the transfer and redevelopment of properties located at 137 Smith Street (Section 12, Block 4, Lot 4.1), 140 Montgomery Street (Section 12, Block 4, Lot 10), and 146 Montgomery Street (Section 12, Block 4, Lot 2.1).

SECOND AMENDMENT TO SITE DEVELOPMENT AGREEMENT

THIS SECOND AMENDMENT TO SITE DEVELOPMENT AGREEMENT (“Amendment”), made as of this _____ day of _____, 2026, by and between the City of Newburgh, a New York municipal corporation, with offices at 83 Broadway, City Hall, Newburgh, New York 12550 (“City”) and The Kearney Realty & Development Group Inc., a domestic business corporation having an address of 57 Route 6, Baldwin Place, New York 10505 (“Developer”).

WITNESSETH:

WHEREAS, pursuant to City Council Resolution 249-2022, on October 24, 2022, the City and Developer executed a Site Development Agreement (“Agreement”) for, among other things, the transfer and redevelopment of properties located at 137 Smith Street (Section 12, Block 4, Lot 4.1), 140 Montgomery Street (Section 12, Block 4, Lot 10), and 146 Montgomery Street (Section 12, Block 4, Lot 2.1) (the “Project”); and

WHEREAS, pursuant to City Council Resolution 199-2025, on September 21, 2025, the City and Developer executed an Amendment to the Agreement extending key performance dates in the Agreement; and

WHEREAS, Developer desires to continue developing the Project to its completion; and

WHEREAS, after completing certain site investigation work and other work related to the Project, the Developer has proposed changes to certain project representations as contained in Schedule E of the Agreement;

WHEREAS, Developer and the City now desire to further amend the Agreement as set forth herein;

NOW, THEREFORE, in consideration of the premises and other good and valuable consideration, the receipt and sufficiency of which are hereby acknowledged, the parties agree as follows:

1. Schedule E as originally set forth in the Agreement shall be replaced in total with the “Amended Schedule E,” annexed hereto and made a part hereof.
2. All other terms and conditions set forth in the Agreement shall remain in full force and effect.

[Remainder of page intentionally left blank. Signature page follows.]

IN WITNESS WHEREOF, the City and the Developer have duly executed this Amendment as of the day and year first above written.

THE CITY OF NEWBURGH

THE KEARNEY REALTY &
DEVELOPMENT GROUP INC.

By: Jason Morris, Interim City Manager
Per Resolution No.: _____-2026

By: Sean Kearney, Vice President

DRAFT

AMENDED SCHEDULE "E"
ADDITIONAL DEVELOPER REPRESENTATIONS

Project Name: The Green

Property: Covering three (3) parcels of real property all located in the City of Newburgh, County of Orange, State of New York, known as 137 Smith Street (Section 12, Block 4, Lot 4.1), 140 Montgomery Street (Section 12, Block 4, Lot 10), and 146 Montgomery Street (Section 12, Block 4, Lot 2.1), all as listed and described on the Official Tax Map of the City of Newburgh.

1. Developer is fully familiar with the City's zoning laws and requirements. Developer's plan does not contemplate requests for use variances or area variances, with the exception of an area variance for off-street parking.
2. Developer's plan shall include a central greenway and courtyard, community garden, rain garden, and community garden which comprise a minimum of approximately 2,000 square feet of space on the Premises.
3. Developer's plan shall include a permanent, on-site property manager to address residential and commercial tenant concerns.
4. Developer's plan shall include free wi-fi access for residential tenants.

5. ~~Developer's plan shall include two (2) retail spaces comprising approximately 2,488 square feet and 2,829 square feet, respectively, subject to changes requested or required by City land use boards in connection with Developer's pursuit of the Approvals and Permits.~~

Developer's plan shall include three (3) retail spaces comprising approximately 2,723 square feet, 893 square feet, and 797 square feet, respectively, subject to changes requested or required by City land use boards in connection with Developer's pursuit of the Approvals and Permits.

6. ~~Developer's plan shall include a third retail space comprising approximately 1,580 square feet. Developer shall be responsible for obtaining a Certificate of Occupancy for a proposed retail use and renting said retail space to a minority or woman-owned business, where the principal operator of said business is a resident of the City of Newburgh, and rent is fixed at no greater than \$10,400.00 annually (\$866.67 monthly) for a period of 3 years.~~

Developer's plan shall include a fourth retail space comprising approximately 1,199 square feet. Developer shall be responsible for obtaining a Certificate of Occupancy for a proposed retail use and renting said retail space to a minority or woman-owned business, where the principal operator of said business is a resident of the City of Newburgh, and rent is fixed at no greater than \$7,889.42 annually (\$657.45 monthly) for a period of 3 years. Thereafter, provided that said retail tenant is otherwise compliant in all respects with the lease in effect at the end of the third year, Developer shall offer subsequent renewal leases term(s) no less than one (1) year in length and rent increases (for the fourth and fifth years only) of no greater than four percent (4%) of the prior year's annual lease amount. .

6.7. ~~Developer's plan shall include approximately 101-122 residential units, serving households earning 40%, 60%, 80%, and approximately 110%100% of the then current Average~~

Median Income for Orange County. Developer shall, subject to the review and approval by New York State Homes and Community Renewal's Fair and Equitable Housing Office, develop and administer an application process that gives primary priority rental preference to prospective tenants who:

- a) Currently reside within three (3) square miles of the project area; and
- b) Can demonstrate that he/she/they had one or more ancestor(s) in a direct line of descendancy (i.e. parent, grandparent, great grandparent, etc.) who owned property that was later acquired by the Newburgh Urban Renewal Agency or was the subject of an "Urban Renewal Land Disposition Agreement."

and gives secondary priority rental preference to prospective tenants who meet either of the above criteria.

~~7.8.~~ Developer's final plan shall include a certification from Developer and Developer's Architect that its plan complies with both the New York State Energy Code and Leadership in Energy and Environmental Design ("LEED") minimum requirements.

~~8.9.~~ Supplementing Section 2.01(d), should Developer fail to receive a Governmental Award, Developer shall have one additional opportunity to apply for such Governmental Award at the next available award cycle. Should said Governmental Award no longer be available, Developer fail to timely apply, or Developer not receive said Governmental award at the next available award cycle, the City may cancel this Agreement its sole discretion, and the Parties shall owe no further obligations to each other.

~~9.10.~~ Developer shall comply with the requirements of Section 3 of the Housing and Urban Development Act of 1968, as amended, 12 U.S.C. 1701u ("Section 3"), as follows:

- a) Developer agrees to comply with federal regulations in 24 CFR part 75, which implements Section 3. Developer certifies that it is under no contractual or other impediment that would prevent it from complying with the Part 75 regulations.
- b) Developer agrees to agrees to notify potential contractors and subcontractors that are associated with Section 3 covered projects and activities about the requirements of Section 3, to include this Section 3 clause in every contract and subcontract subject to compliance with regulations in 24 CFR Part 75, and to ensure that any subcontractors also include this Section 3 clause in their subcontracts for work performed on the project.
- c) Developer will not subcontract with any subcontractor where the contractor has notice or knowledge that the subcontractor has been found in violation of the regulations in 24 CFR Part 75.
- d) Developer agrees to maintain hiring and contracting practices to the greatest extent feasible so that 25 percent of the total labor hours expended on the project are by Section 3 Workers, of which 5 percent are by Targeted Section 3 Workers as defined in 24 CFR part 75. As part of these practices, Developer agrees to provide priority consideration to eligible residents and businesses in accordance with 24 CFR Part 75, and eligible residents who reside within one (1) square mile of the Project

Premises. If Developer is not able to meet this benchmark goal, it must provide a narrative of efforts taken and supporting documentation explaining why it was unable to meet that goal, despite greatest extent feasible efforts taken.

- e) Developer shall offer opportunities to Section 3 Workers to attend social and networking events related to the Project, opportunities to attend project management meetings, and opportunities to meet and interact with Developer's senior management team throughout the course of the Project. Said efforts shall be documented in accordance with this paragraph (9).
- f) Developer agrees to comply with all monitoring, reporting, recordkeeping, and other procedures specified by the City. Developer is responsible for providing Section 3 performance metrics and supporting documentation for all its subrecipients, contractors, and subcontractors, as applicable. At a minimum, Developer shall complete and submit to City a "New York State Homes and Community Renewal Section 3 Sub Reporting Form & Greatest Extent Feasible Efforts Checklist" within the first six (6) months of the Project start and every six (6) months thereafter until Project completion. Developer shall also submit a final report at the completion of the Project.
- g) Noncompliance with HUD's regulations in 24 CFR Part 75 may result in sanctions, penalties, and/or termination of this contract for default.

11. The Developer will commit to incorporating an internship program for two (2) City of Newburgh residents during the construction phase of the Project. The internships will be paid and will provide experience in general contracting, real estate development, and real estate management.

RESOLUTION NO.: 199 - 2025

OF

SEPTEMBER 8, 2025

A RESOLUTION AUTHORIZING THE CITY MANAGER TO EXECUTE AN
AMENDMENT TO A SITE DEVELOPMENT AGREEMENT WITH
THE KEARNEY REALTY & DEVELOPMENT GROUP INC. FOR THE TRANSFER
AND REDEVELOPMENT OF PROPERTIES LOCATED AT
137 SMITH STREET (SECTION 12, BLOCK 4, LOT 4.1),
140 MONTGOMERY STREET (SECTION 12, BLOCK 4, LOT 10), AND
146 MONTGOMERY STREET (SECTION 12, BLOCK 4, LOT 2.1)

WHEREAS, by Resolution No. 249-2022, the City of Newburgh authorized execution of a Site Development Agreement with The Kearney Realty & Development Group Inc. for the transfer and redevelopment of properties located at 137 Smith Street (Section 12, Block 4, Lot 4.1), 140 Montgomery Street (Section 12, Block 4, Lot 10), and 146 Montgomery Street (Section 12, Block 4, Lot 2.1); and

WHEREAS, The Kearney Realty & Development Group Inc. requested a six (6) month extension of time to close title in accordance with the Site Development Agreement, and the City Manager granted the request to extend the time to close title until April 24, 2025; and

WHEREAS, Sean Kearney, Vice President of The Kearney Realty & Development Group Inc., has requested an extension of time to meet certain key performance dates contained in the Site Development Agreement; and

WHEREAS, the City Council of the City of Newburgh finds that approving an amendment to the Site Development Agreement that modifies said key performance dates is in the best interests of the City of Newburgh;

NOW, THEREFORE, BE IT RESOLVED, by the Council of the City of Newburgh, New York that the City Manager be and he is hereby authorized to enter into the attached Amendment to the Site Development Agreement with The Kearney Realty & Development Group Inc. for the transfer and redevelopment of properties located at 137 Smith Street (Section 12, Block 4, Lot 4.1), 140 Montgomery Street (Section 12, Block 4, Lot 10), and 146 Montgomery Street (Section 12, Block 4, Lot 2.1).

I, Katrina Cotten, City Clerk of the City of Newburgh hereby certify that I have compared the foregoing with the original resolution adopted by the Council of the City of Newburgh at a regular meeting held Sept. 8, 2025 and that it is a true and correct copy of such original.

Witness my hand and seal of the City of Newburgh this 9th day of Sept. 20 25

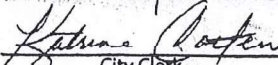
City Clerk

RESOLUTION NO.: 249 - 2022

OF

OCTOBER 11, 2022

A RESOLUTION AUTHORIZING THE CITY MANAGER TO EXECUTE A SITE DEVELOPMENT AGREEMENT WITH THE KEARNEY REALTY & DEVELOPMENT GROUP INC. FOR THE TRANSFER AND REDEVELOPMENT OF PROPERTIES LOCATED AT 137 SMITH STREET (SECTION 12, BLOCK 4, LOT 4.1), 140 MONTGOMERY STREET (SECTION 12, BLOCK 4, LOT 10), AND 146 MONTGOMERY STREET (SECTION 12, BLOCK 4, LOT 2.1)

WHEREAS, the City of Newburgh wishes to redevelop City-owned properties located at 137 Smith Street (Section 12, Block 4, Lot 4.1), 140 Montgomery Street (Section 12, Block 4, Lot 10), and 146 Montgomery Street (Section 12, Block 4, Lot 2.1) (collectively the "Properties"); and

WHEREAS, the City of Newburgh issued Request for Proposals ("RFP") No. 6.21 to solicit for plans to redevelop the Properties; and

WHEREAS, the Mayor's Strategic Economic Development Advisory Committee ("SEDAC") reviewed all of the proposals submitted in connection with the RFP and recommended the proposal to redevelop the Properties set forth by The Kearney Realty & Development Group Inc. to the City Council; and

WHEREAS, the City Council caused a public hearing to be duly noticed and convened and completed a public hearing on September 12, 2022; and

WHEREAS, the parties have negotiated a site development agreement for the transfer and redevelopment of the Property, which is annexed hereto; and

WHEREAS, this Council finds that the Properties are not required for public use and that approving such site development agreement is necessary, appropriate and in the best interests of the City;

NOW, THEREFORE, BE IT RESOLVED, by the Council of the City of Newburgh that the City Manager be and he is hereby authorized to execute on behalf of the City of Newburgh the site development agreement with The Kearney Realty & Development Group Inc. (by Kenneth Kearney, as president), in substantially the same form as annexed hereto with other provisions as Corporation Counsel may require, for the transfer and redevelopment of the properties located at 137 Smith Street, 140 Montgomery Street, and 146 Montgomery Street.

I, Lorene Vitek, City Clerk of the City of Newburgh, hereby certify that I have compared the foregoing with the original resolution adopted by the Council of the City of Newburgh at a regular meeting held Oct 11, 2022 and that it is a true and correct copy of such original.

Witness my hand and seal of the City of Newburgh this 11 day of Oct, 20 22

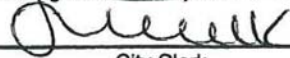
City Clerk

RESOLUTION NO.: 81 - 2026

OF

APRIL 27, 2026

**A RESOLUTION AUTHORIZING THE CITY MANAGER TO EXECUTE
AN AGREEMENT FOR THE PAYMENT IN LIEU OF TAXES BETWEEN
THE CITY OF NEWBURGH, THE GREEN HOUSING DEVELOPMENT FUND
COMPANY, INC., AND NEWBURGH GREEN APARTMENTS LIMITED PARTNERSHIP**

WHEREAS, the City of Newburgh (the “City”) encourages a sufficient supply of adequate, safe and sanitary dwelling accommodations properly planned for low and moderate-income individuals; and

WHEREAS, by Resolution No. 249-2022, the City Council selected The Kearney Realty & Development Group Inc. for the transfer and development of property located at City-owned properties located at 137 Smith Street (Section 12, Block 4, Lot 4.1), 140 Montgomery Street (Section 12, Block 4, Lot 10), and 146 Montgomery Street (Section 12, Block 4, Lot 2.1) (collectively the “Properties”) in a manner that would provide affordable housing options to persons of low and moderate-income; and

WHEREAS, The Kearney Realty & Development Group Inc. intends to become a partner in a housing development fund corporation (“HDFC”) known as The Green Housing Development Fund Company, Inc., a New York not-for-profit corporation organized under Article XI of the New York Private Housing Finance Law (“PHFL”) and Section 402 of the New York State Not-for-Profit Corporation Law; and

WHEREAS, the HDFC will become the record owner of the Properties, which shall be used for the purpose of providing approximately 122 residential units for individuals and families of low to moderate income, an on-site superintendent unit, and approximately 5,612 square feet of commercial space (the “Project”); and

WHEREAS, the HDFC’s plan for the continued use of the Properties constitutes a “housing project” as that term is defined in the PHFL; and

WHEREAS, the HDFC is a “housing development fund company” as the term is defined in Section 572 of the PHFL, and Section 577 of the PHFL authorizes the City Council to exempt the Properties from real property taxes; and

WHEREAS, The Kearney Realty & Development Group Inc., acting on behalf of The Green Housing Development Fund Company, Inc. and Newburgh Green Apartments Limited Partnership, seeks a PILOT agreement (“Agreement”) whereby the HDFC will make annual payments in lieu of taxes to the City as set forth in the Agreement below, now presented to the City Council for approval; and

NOW THEREFORE, BE IT RESOLVED, that the members of the City Council hereby exempts the Properties from real property taxes to the extent authorized by Section 577 of the PHFL and approve the proposed PILOT Agreement by and among the City of Newburgh, the HDFC, and Newburgh Green Apartments Limited Partnership, which provides for annual payments as set forth in such agreement; and

BE IT FURTHER RESOLVED, that the City Manager is hereby authorized to execute and deliver the foregoing PILOT Agreement, in substantially the same form with other documents as Corporation Counsel may require, on behalf of the City.

AGREEMENT FOR PAYMENT IN LIEU OF TAXES (“PILOT”) BY AND AMONG THE CITY OF NEWBURGH, THE GREEN HOUSING DEVELOPMENT FUND COMPANY, INC. AND NEWBURGH GREEN APARTMENTS LIMITED PARTNERSHIP

THIS AGREEMENT FOR PAYMENT IN LIEU OF TAXES (the “PILOT Agreement” or “Agreement”), dated as of _____, 2026, by and among the **CITY OF NEWBURGH, NEW YORK**, a New York municipal corporation, having its principal office located at 83 Broadway, Newburgh, New York 12550 (the “City”) and **THE GREEN HOUSING DEVELOPMENT FUND COMPANY, INC.**, a New York not-for-profit corporation and entity organized pursuant to Article XI of the Private Housing Finance law, having its principal place of business at c/o RUPCO, Inc., 289 Fair Street, Kingston, New York 12401 (the “HDFC”), which HDFC will hold title to the Property (as hereinafter defined) for the benefit of **NEWBURGH GREEN APARTMENTS LIMITED PARTNERSHIP**, a New York Limited Partnership, having its principal office located at c/o The Kearney Realty & Development Group Inc., 57 Route 6, Suite 207, Baldwin Place, New York 10505 (the “Company”), (the City, the HDFC, and the Company are collectively referred to as the “Parties”).

WHEREAS, by the First Taxable Status Date as defined in Section 2, below, the HDFC will be the bare legal or record owner, and the Company will be the beneficial and equitable owner, of three (3) parcels of real property all located in the City of Newburgh, County of Orange, State of New York, known as 137 Smith Street (Section 12, Block 4, Lot 4.1), 140 Montgomery Street (Section 12, Block 4, Lot 10), and 146 Montgomery Street (Section 12, Block 4, Lot 2.1), all as listed and described on the Official Tax Map of the City of Newburgh (collectively hereafter referred to as the “Property”); and

WHEREAS, the HDFC is a corporation established pursuant to Section 402 of the Not-For-Profit Corporation Law and Article XI of the Private Housing Finance Law (“PHFL”); and

WHEREAS, by the First Taxable Status Date, as defined in Section 2 below, the HDFC will be the co-general partner of the Company; and

WHEREAS, the HDFC and the Company have each been formed for the primary purpose of providing residential rental accommodations for persons of middle and low income, as well as the construction of approximately 5,612 square feet of commercial retail space; and

WHEREAS, the Company will develop, own, construct, maintain and operate a housing project for persons of middle income and low income on the Property, as well as develop, own, construct, and maintain the commercial retail space (the “Project”); and

WHEREAS, the HDFC’s and the Company’s plan for the use of the Property constitutes a “housing project” as that term is defined in the PHFL; and

WHEREAS, the HDFC is a “housing development fund company” as the term is defined in Section 572 of the PHFL; and

WHEREAS, pursuant to Section 577 of the PHFL, the local legislative body of a municipality may exempt the real property of a housing project of a housing development fund company from local and municipal taxes, including school taxes, other than assessments for local improvements, to the extent of all or a part of the value of the property included in the completed project; and

WHEREAS, the Council Members of the City of Newburgh, New York, by resolution number [REDACTED]-2026 adopted [REDACTED], 2026, approved and authorized the execution of this Agreement;

NOW, THEREFORE, it is agreed as follows:

1. Pursuant to Section 577 of the PHFL, the City hereby exempts from local and municipal taxes, other than assessments for local improvements, one hundred percent (100%) of the value of the Property, including both land and improvements. “Local and Municipal Taxes” shall mean any and all real estate taxes levied by Orange County (“County”), the City, and the Newburgh Enlarged City School District (the “School District”) (the City, the County, and the School District collectively referred to as the “Taxing Jurisdictions”).
2. This tax exemption will operate for a period of **thirty (30) years**, measured from the City’s first taxable status date following the date that a permanent certificate of occupancy (“Certificate of Occupancy”) is issued by the City (“First Taxable Status Date”). This Agreement shall not limit or restrict the HDFC’s or Company’s right to apply for or obtain any other tax exemption to which it might be entitled upon the expiration of this Agreement. The parties understand that the exemption extended pursuant to Section 577 of the PHFL and this Agreement does not include exemption from assessments for local improvements, special assessments, or special ad valorem levies. During the period of this Agreement, the Company shall pay any service charges, special ad valorem levies, special assessments and improvement district charges or similar tax equivalents which are or would be levied upon or with respect to the Project by the Taxing Jurisdictions or any other taxing authority.
3. So long as the exemption hereunder continues, the Company shall make annual payments in lieu of taxes (“PILOT”) in the amounts set forth in section 3(a) below, measured from the First Taxable Status Date, which payments shall cover all Local and Municipal Taxes owed in connection with the Property and the Project, and which payment shall be shared by Taxing Jurisdictions on the same basis as property taxes would be shared if the Property and the Project were fully taxed. So long as the tax exemption remains in effect, tenant rental charges shall not exceed the maximum established or allowed by law, rule or regulation, and the Property shall be operated in conformance with the provisions of Article XI of PHFL.
4. The first PILOT for the Property shall be in the amount of \$175,700.00 for the first taxable year and shall increase annually at the rate of three percent (3%). The annual payment schedule is annexed hereto as **Exhibit A**.
 - a. The first PILOT payment shall be made on or before February 15 of the calendar year following the first taxable year as contemplated in Section 2. Subsequent PILOT payments shall be due and received by the City on or before **February 15** of the calendar year to which this Agreement applies. The PILOT payment shall be payable to the “City of

Newburgh.” The PILOT payment shall be mailed via first class mail through the United States Postal Service or personally delivered to the City of Newburgh, attention Tax Collector, 83 Broadway, Newburgh, New York 12550, or such other address as the City may specify in writing.

- b. The HDFC and the Company agree that any PILOT payment will not be reduced for any reason, nor will the HDFC or the Company seek to commence any action(s) to reduce a PILOT payment, as these factors have been considered in arriving at the payment amounts reflected in this Agreement.
 - c. The HDFC and the Company shall continue to pay all water, sewer, and sanitation charges in accordance with the assessments and rates established by the City.
5. The tax exemption provided by this Agreement will continue for the term described above provided that (a) the Property continues to be used in accordance with certain representations made in Schedule E of a Site Development Agreement dated October 24, 2022 (and as may be amended from time to time) between the City of Newburgh and The Kearney Realty & Development Group Inc., and (b) any of the following occur (i) the HDFC and the Company operate the Property in conformance with Article XI of the PHFL; or (ii) the HDFC assumes sole legal ownership of the Property and the Company assumes sole beneficial ownership of the Property and operates the Property in conformance with Article XI of the PHFL; or (iii) in the event an action is brought to foreclose a mortgage upon the HDFC, and the legal and beneficial interest in the Project shall be acquired at the foreclosure sale or from the mortgagee, or by a conveyance in lieu of such sale, by a housing development fund corporation organized pursuant to Article XI of the PHFL, or by the Federal government or an instrumentality thereof, or by a corporation which is, or by agreement has become subject to the supervision of the superintendent of banks or the superintendent of insurance, such successor in interest, such successor in interest shall operate the property in conformance with Article XI of the PHFL; and (c) none of the Parties are in default under this Agreement.
6. Following the issuance of a permanent Certificate of Occupancy, the HDFC and the Company shall be required to obtain a Rental License from the City in accordance with Chapter 240 of the City of Newburgh Code of Ordinances (and as may be amended) (the “Code”). The HDFC and the Company shall make application to the City’s Code Compliance Bureau for a Rental License and any subsequent Rental License renewals no later than 60 days prior to the expiration date of the Rental License then in effect. Inability to provide access to a dwelling unit shall not be a defense to the HDFC’s and/or the Company’s ability to obtain a Rental License.
- i. The expiration or lapse of a Rental License for more than 60 days after the expiration date of the Rental License then in effect shall be grounds for default and termination of this Agreement, unless:
 - 1. The expiration or lapse results from a *force majeure*, a casualty caused by anyone other than an employee or agent of Company or the HDFC, the actions of an occupant of the Property, or the actions of a guest or invitee of an occupant of the Property, including but not limited to actions outlined in Code Sections 240-14(E)(3), (4), (5), (6), (7), or (8); and

2. The Company and HDFC are diligently taking steps to abate and resolve such actions, including, without limitation, seeking to evict such offending occupant, or taking steps to remedy the casualty.

~~6.7.~~ Failure to make a scheduled PILOT Payment will be treated as failure to make payment of taxes and will be governed by the same provisions of law as apply to the failure to make payment of taxes, including but not limited to imposition of penalty and interest charges as allowed under state and local law, and enforcement and collection of taxes to the extent permitted by law. Any payment not received by its due date shall accrue interest and penalties at the rates provided for late payment of taxes to the Taxing Jurisdictions.

~~7.8.~~ Failure to make PILOT payments when due, as required pursuant to Section 4 of this Agreement, and which failure continues for more than thirty (30) days following written notice from the City shall constitute an Event of Default hereunder (“Event of Default” or “Default”).

- a. Whenever an Event of Default under this Agreement for failure to make required PILOT Payments shall have occurred and be continuing, the City shall have the following remedies: The City may terminate this Agreement and exercise all of the rights and remedies available for failure to pay property taxes accruing following the date of termination as and when due had this Agreement not been in effect. The City may take whatever action at law or in equity as may appear necessary or desirable to collect the amount then in default or to enforce the performance and observance of the obligations, agreements and covenants of HDFC and the Company under this Agreement, and the Company shall further pay the reasonable fees and disbursements of such attorneys as the City shall engage for the enforcement of performance or observance of any obligation, covenant or agreement on the part of HDFC and the Company and all other reasonable expenses, costs and disbursements so incurred.
- b. No remedy herein conferred reserved is intended to be exclusive of any other available remedy or remedies, but each and every such remedy shall be cumulative and shall be in addition to every other remedy given under this Agreement or now or hereafter existing at law or in equity or by statute.
- c. No delay or omission in exercising any remedy shall impair any such remedy or construed to be a waiver thereof. It shall not be necessary to give any notice other than as expressly required under this Agreement. In the event any provision contained in this Agreement should be breached and thereafter duly waived by the party or parties so empowered to act, such waiver shall be limited to the particular breach so waived and shall not be deemed to be a waiver of any other breach hereunder.

~~8.9.~~ All notices and other communications hereunder shall be in writing and shall be sufficiently given when delivered to the applicable addresses stated in **Exhibit B** (or such other address as the party to whom notice is given shall have specified to the party giving notice) by registered or certified mail, return receipt requested or by such other means as shall provide the sender with documentary evidence of such delivery. This provision shall not apply in the event that the HDFC, its successors or assigns, become subject to the City’s procedures with respect to the collection of delinquent taxes.

- a. With respect to any notice(s) of Default in accordance with Section 8 that may be issued by the City to the HDFC and/or the Company under the terms of this Agreement, the City shall also provide Project lenders with such notice(s) of Default at the following addresses (or such other address(es) as any Project lender shall provide in writing to the City Clerk and City's Office of the Corporation Counsel):

Lender: New York State Housing Finance Agency
attn: President, Finance and Development
641 Lexington Avenue
New York, New York 10022

with copy to:

New York State Housing Finance Agency
Attn: Senior Vice President and Counsel
641 Lexington Avenue
New York, New York 10022

Bank: TD Bank, N.A.
One Vanderbilt, 14th Floor
New York, NY 10017
Attention: Matthew Schatz, Market Leader

Investor: RJ MT Newburgh Green Apartments L.L.C.
c/o Raymond James Affordable Housing Investments, Inc.
880 Carillon Parkway
St. Petersburg, Florida 33716
Email Address: Steve.Kropf@RaymondJames.com
Attention: Steven J. Kropf, President

With copies to:
Dawna J. Steelman, Esq.
Klein Hornig LLP
1325 G Street NW, Suite 770
Washington, DC 20005
mail Address: dsteelman@kleinhornig.com

[]

[]

[]

9.10. This Agreement shall inure to the benefit of and shall be binding upon the City the Company and the HDFC and their respective successors and assigns, including the successors in interest of the Company and the HDFC. There shall be no assignment of this Agreement except with consent of the other party, which consent shall not be unreasonably withheld. In the event that the Company and the HDFC seeks to assign this agreement, the Company and the HDFC must demonstrate to the City, at a minimum, that the record owner of the Property is a housing development fund company subject to Article XI of the PHFL, the assignee is willing to assume the obligations of this Agreement in writing, and the assignee shall have

provided such financial and other information as shall be reasonably requested by the City in order to assure the proper completion and operation of the housing project and the compliance with the terms of this Agreement and all applicable laws, regulations and covenants.

~~10.11.~~ If any provision of this Agreement or its application is held invalid or unenforceable to any extent, the remainder of this Agreement and the application of that provision to other persons or circumstances shall be enforced to the greatest extent permitted by law.

~~11.12.~~ This Agreement may be executed in any number of counterparts with the same effect as if all the signing parties had signed the same document. All counterparts shall be construed together and shall constitute the same instrument.

~~12.13.~~ This Agreement constitutes the entire agreement of the parties relating to payments in lieu of taxes with respect to the Property and supersedes all prior contracts, or agreements, whether oral or written, with respect thereto.

~~13.14.~~ Each of the parties individually represents and warrants that the execution, delivery and performance of this Agreement, (i) has been duly authorized by proper action of its governing body and does not require any other consent or approval for the execution thereof by such municipality, (ii) does not violate any law, rule, regulation, order, writ, judgment or decree by which it is bound, and (iii) will not result in or constitute a default under any agreement or instrument to which it is a party. Each such party represents that this Agreement shall constitute the legal, valid and binding agreement of such party enforceable in accordance with its terms.

~~14.15.~~ The Company and HDFC jointly and severally make the following representations, warranties and covenants:

- a. The HDFC is a “housing development fund company” under Article XI of the PHFL, and the Company is a limited partnership, the co-general partner of which is the HDFC, each of which is organized, validly existing and in good standing under the laws of the State and is authorized under the laws of the State to do business in the State, has the power to enter into this Agreement and to perform the transactions contemplated hereby and its obligations hereunder and by proper action has duly authorized the execution and delivery of this Agreement and the performance of its obligations hereunder, and the execution, delivery and performance of this Agreement does not require any other consent or approval. This Agreement shall constitute the legal, valid and binding agreement of HDFC and the Company enforceable in accordance with its terms.
- b. Neither the Company nor HDFC is in default under, or in violation of, any indenture, mortgage, declaration, lien, lease, contract, note, order, judgment, decree or other instrument of any kind to which any of its assets are subject, and the execution, delivery and compliance by the Company or HDFC with the terms and conditions of this Agreement do not and will not conflict with or constitute or result in a default by the Company or HDFC in any material respect under or violation of, (1) the entity’s organizational documents, (2) any agreement or other instrument to which such entity is a party or by which, to such entity’s knowledge, it is bound, or (3) any constitutional or statutory provision or order, rule, regulation, decree or ordinance of any court, government or

governmental authority having jurisdiction over the Company or HDFC or its property, and no event has occurred and is continuing which, with the lapse of time or the giving of notice, or both, would constitute or result in such a default or violation.

- c. The Company has provided to the City true and complete financial information with respect to the Property, including without limitation project costs, financing sources, rents and income limitations.
- d. The Company covenants and agrees to operate the Property in accordance with all applicable rules and regulations of Article XI of the PFHL.
- e. The Company covenants and agrees to provide to the City any information or documents reasonably requested in writing by the City in order to provide any federal, state or local entity with information or reports required under any applicable law, rule or regulation.

15.16. The City shall file a copy of the fully-executed Agreement with the City Assessor. The Company shall be responsible for taking such actions as may be necessary to ensure that the Property shall be assessed as exempt upon the assessment rolls of the respective Taxing Jurisdictions, including without limitation ensuring that any required exemption form shall be filed with the appropriate officer or officers of each respective Taxing Jurisdiction. Such exemption shall be effective as of the first taxable status date of the applicable Taxing Jurisdiction following the date of this Agreement, provided that the Company shall timely file any requisite exemption forms.

16.17. This Agreement shall be governed by and construed in accordance with the laws of the State of New York. The Parties each consent to the jurisdiction of the New York courts in and for the County of Orange regarding any and all matters, including interpretation or enforcement of this Agreement or any of its provisions. Accordingly, any litigation arising hereunder shall be brought solely in such courts.

17.18. Entire Agreement. The Parties agree that this is the entire, fully integrated Agreement between them.

18.19. Amendments. This Agreement may not be amended, changed, modified, altered or terminated except by an instrument in writing executed by the Parties hereto.

19.20. No Third Party Beneficiaries. The Parties state that there are no third-party beneficiaries to this Agreement.

20.21. All Terms Material. Each and every term and condition of this Agreement is of the essence and constitutes a material part of the bargained-for consideration, without which this Agreement would not have been executed.

21.22. This Agreement shall be deemed withdrawn unless fully-executed by the Parties on or before December 31, 2026.

[Remainder of page intentionally left blank.
Signature page to follow.]

IN WITNESS WHEREOF, the City, the HDFC and the Company have caused this Agreement to be executed in their respective names by their duly authorized representatives and their respective seals to be hereunder affixed, all as of the date above-written.

DATED: _____, 2026

CITY OF NEWBURGH

By: _____

Name:

Title: City Manager

DATED: _____, 2026

THE GREEN HOUSING DEVELOPMENT
FUND COMPANY, INC.

By: _____

Name: Kevin O'Connor

Title: President

DATED: _____, 2026

NEWBURGH GREEN APARTMENTS LIMITED
PARTNERSHIP

By: THE GREEN ASSOCIATES MGP, LLC
its managing general partner

By: _____

Name: Kenneth Kearney

Title: Manager

Exhibit A (Payment Schedule)

(Numeric Refers to the Annual PILOT Year)

| | |
|-----|---------------------|
| 1. | <u>\$175,700.00</u> |
| 2. | <u>\$180,971.00</u> |
| 3. | <u>\$186,400.13</u> |
| 4. | <u>\$191,992.13</u> |
| 5. | <u>\$197,751.90</u> |
| 6. | <u>\$203,684.45</u> |
| 7. | <u>\$209,794.99</u> |
| 8. | <u>\$216,088.84</u> |
| 9. | <u>\$222,571.50</u> |
| 10. | <u>\$229,248.65</u> |
| 11. | <u>\$236,126.11</u> |
| 12. | <u>\$243,209.89</u> |
| 13. | <u>\$250,506.19</u> |
| 14. | <u>\$258,021.37</u> |
| 15. | <u>\$265,762.01</u> |
| 16. | <u>\$273,734.88</u> |
| 17. | <u>\$281,946.92</u> |
| 18. | <u>\$290,405.33</u> |
| 19. | <u>\$299,117.49</u> |
| 20. | <u>\$308,091.01</u> |
| 21. | <u>\$317,333.74</u> |
| 22. | <u>\$326,853.76</u> |
| 23. | <u>\$336,659.37</u> |
| 24. | <u>\$346,759.15</u> |
| 25. | <u>\$357,161.92</u> |
| 26. | <u>\$367,876.78</u> |
| 27. | <u>\$378,913.09</u> |
| 28. | <u>\$390,280.48</u> |
| 29. | <u>\$401,988.89</u> |
| 30. | <u>\$414,048.56</u> |

Exhibit B (Notices)

City of Newburgh

City of Newburgh
attn: City Clerk
83 Broadway
Newburgh, New York 12550

City of Newburgh
attn: Office of the Corporation Counsel
83 Broadway
Newburgh, New York 12550

The Green Housing Development Fund Company, Inc.

c/o RUPCO, Inc.
attn: Kevin O'Connor, Chief Executive Officer
289 Fair Street
Kingston, New York 12401

Newburgh Green Apartments Limited Partnership

c/o The Kearney Realty & Development Group Inc.
attn: Kenneth Kearney
57 Route 6, Suite 207
Baldwin Place, New York 10505

Project Lender

New York State Housing Finance Agency
attn: President, Finance and Development
641 Lexington Avenue
New York, New York 10022

New York State Housing Finance Agency
attn: Senior Vice President and Counsel
641 Lexington Avenue
New York, New York 10022



57 Route 6, Suite 207
Baldwin Place, New York 10505
Telephone: 845.306.7705
Fax: 845.306.7707

January 2, 2026

Todd Venning
City Manager
City of Newburgh
83 Broadway
Newburgh, NY 12550

Re: Request for Payment-In-Lieu-Of-Taxes (PILOT) Agreement – The Green

Dear City Manager Venning,

On behalf of Kearney Realty & Development Group, Inc., I respectfully submit this letter to formally request the City of Newburgh's consideration of a Payment-In-Lieu-Of-Taxes (PILOT) Agreement for the development known as The Green.

As you are aware, The Green is being developed pursuant to the existing Site Development Agreement between Kearney Realty & Development Group, Inc. and the City of Newburgh, which was authorized by City of Newburgh's Common Council Resolution No. 249-2022. That resolution followed the recommendation of the Strategic Economic Development Committee and the Common Council's selection of Kearney Realty & Development Group's response to the City's Request for Proposals "RFP #6.21 – Purchase and Development of City-Owned Parcels at 140 & 146 Montgomery Street, and 137 Smith Street."

We are pleased to confirm that The Green has been developed consistent with the Developer Representations set forth in Schedule E of the Site Development Agreement, specifically, The Green will include mixed-income housing for households earning up to 40%, 60%, 80%, and 100% of Orange County's Area Median Income, The Green will be mixed-use (commercial and residential), The Green will include a commercial space at below market rent for a minority or woman-owned small business owner, The Green will be LEED Certified, and The Green will include a local preference as well as a "Right of Return" preference to individuals or families who were displaced by Urban Renewal.

The project is currently scheduled to close with the New York State Housing Finance Agency (HFA) in March 2026. In order to support that closing timeline and provide certainty to all financing partners, we respectfully request that the PILOT Agreement be finalized by mid-February 2026, if possible.

To assist the City in its review, Cheryl Sarjeant of Cannon Heyman & Weiss, LLP will be working with Kearney Realty & Development Group, Inc. on the preparation of a draft PILOT Agreement for the

Common Council's consideration. Copies of the proposed agreement will also be provided to the Corporation Counsel for review and comment.

We appreciate the City of Newburgh's continued partnership and support of The Green, and we look forward to working collaboratively with your office, the Common Council, and City staff to advance this request in a timely manner. Please do not hesitate to contact me should you require any additional information or documentation.

Respectfully submitted,



Sean Kearney

President

Kearney Realty & Development Group, Inc.

cc:

Mike Neppl

Omar E. Balbuena-Palma

Michelle Kelson

Jeremy Kaufman

Richard J. Lampert

Real Estate Consulting and Market Research

Richard.Lampert@verizon.net

March 31, 2026

Mr. Sean Kearney – Managing Member
Kearney Realty & Development Group, Inc.
57 Route 6, Suite 207
Baldwin Place, New York 10505

Re: The Green Apartments – 581(a) Appraisal:

Dear Mr. Kearney,

In accordance with your requirements, I have undertaken an appraisal of an affordable development property located in the City of Newburgh, New York. This appraisal is being prepared for refinancing apparition. The valuation method as mandated by RPTL 581-a is only the income approach. This has created a *Jurisdictional Exception*, as noted in this report.

The proposed property is a 122-unit apartment development located at 140 Montgomery Street Newburgh New York 12555. The site is situated in a low-income neighborhood of the city that is occupied by high percentage of renters -75%.

The property could be assessed and conforms to the S-581-A, the assessment of residential properties.

I believe that the estimate is a reasonable reflection of the real estate taxes for 2024/ 2025 and is subject to your review and analysis of all revenues, expenses, and guidelines. The 581a analysis only impacts expenses based on mill rate calculation - (assessment x mill rate).

However, the actual real estate taxes are based on the date the property enters service, the rents at that time (*HUD/NYS-HCR – formula*), estimate tenant utility allowances by unit type, actual expenses, mill rates and effective capitalization rates for similar factors and conditions.

The subject property is appraised to estimate its market value, in a fee simple interest, as of March 26, 2026. After carefully considering supply and demand factors influencing the property, and transactions of competitive properties, I conclude the Market Value with 2025 rents and expenses of the fee simple interest of the Green Apartments, as of March 26, 2026, as follows:

Eight Million Seven Hundred Fifty Thousand Dollars
\$8,750,000 - \$71,800+/- per unit

Attached herewith is my consulting report that outlines all computations, methods of approach and pertinent facts that were considered in estimating the assessment value of the subject property.

Respectively submitted,



Richard J. Lampert
NYS - General Certified Real Estate Appraiser # 6405

Table of Contents

| | |
|--|----|
| Report Certification | 1 |
| Trends in Affordable Housing and 581 (a) Analysis | 2 |
| S-581-a Stature | 4 |
| Valuation Analysis Chart – Calculation of 581a Real Estate Taxes | 5 |
| Income Approach to Valuations | 6 |
| Rent Roll | 7 |
| Projected Expenses | 9 |
| Capitalization Rate Development` | 8 |
| Capitalization Rate Survey | 10 |
| Final Reconciliation - Market and Assessment Values | 11 |
| Property and Demographics Summy | 12 |
| Proposed Development..... | 14 |
| Tax Parcel Map | 15 |
| Flood Plain Map | 16 |
| Photographs of the property | 17 |
| Demographic Overview of the City of Newburg..... | 19 |
| Use, intended users, Rights Appraised, Personal Property, and History of Property | 33 |
| Scope of The Assignment..... | 33 |
| Definition of Value, other definitions, and Exposure and Marketing Time..... | 34 |
| Contingent and Limited Conditions | 36 |
| Professional Qualifications of the Appraiser | 38 |
| Addenda | 40 |

Report Certification

I certify that, to the best of my knowledge and belief:

- The statements of fact contained in this report are true and correct.
- The reported analysis, opinions, and conclusions are limited only by the reported assumptions and limiting conditions, and is my personal, unbiased professional analysis, opinions, and conclusions.
- I have no present or prospective interest in the property that is the subject of this report, and I have no personal interest or basis with respect to the parties involved.
- My compensation is not contingent upon the reporting of a predetermined value or direction in value that favors the cause of the client, the amount of the value estimate, the attainment of a stipulated result, or the occurrence of a subsequent event resulting from the analysis, opinions, or conclusions in, or the use, of this report.
- My analysis, opinions, and conclusions were developed, and this report has been prepared, in conformity with the Uniform Standards of Professional Appraisal Practice. The use of this report is subject to the requirements of the Appraisal Institute relating to review by its duly authorized representatives.
- I, Richard J. Lampert, did inspect the site on March 26, 2026, that is the subject of this report. No one provided significant professional assistance to the person(s) signing this report.
- The appraisal was not based on a requested minimum valuation, a specific valuation, or the approval of a loan.
- I, Richard J. Lampert, hereby acknowledge that I have the appropriate education and experience to complete the assignment in a competent manner.
- I have performed no services, as an appraiser or in any other capacity, regarding the property that is the subject of this report within the three-year period immediately preceding acceptance of this assignment.
- The valuation method for this assignment is based on 581-a Stature.

The subject property is appraised to estimate its market value, in a fee simple interest, as of March 26, 2026. After carefully considering supply and demand factors influencing the property, and transactions of competitive properties, I conclude the Market Value with 2025 rents and expenses of the fee simple interest of the Green Apartments, as of March 26, 2026, as follows:

Eight Million Seven Hundred Fifty Thousand Dollars
\$8,750,000 - \$71,800+/- per unit

Attached herewith is my detailed appraisal report that outlines all computations, methods of approach and pertinent facts that were considered in estimating the Market Value of the property.

Respectively submitted,

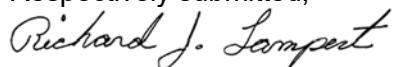

Richard J. Lampert

NYS - General Certified Real Estate Appraiser #6405

Trends in Affordable Rental Housing and 581-a Stature.

Prior to 1980's, the Federal Government policy toward housing was to provide development and operating assistance for low-income housing via the older 236 Program with HAP contracts, Section Eight (*New construction and existing housing*) and the smaller 515 Rural Development and 202 Senior Housing programs.

Both the Federal government and state government wanted to exit out of the annual rental subsidy program because of increasing costs and only marginal increases in new affordable housing stock.

By the year 2000, the Federal government had exited the standard operating subsidy program for housing, except for the 515 Rural Development Program and 202 housing programs for seniors. Over 90+% of all new affordable housing is developed under the Low-Income Housing Tax Credit (*LIHTC*) program.

Some states, including New York, have developed a State Low Income Housing Tax Credit (*SLIHTC*) for state Income taxes which this program has a few projects.

The concept of this program is to offset the development costs and expenses of new construction and renovations and limit the Federal government exposure for operating subsidies. Once the property is built, it should operate on its own cash flow, subject to HUD and New York Division of Housing and Community Renewal (*NYS-HCR*) requirements. In the long-term, the Federal and State governments will save billions of dollars. The rents will stay low because the debt structure is minimal.

However, the low rents and government restrictions result in marginal financially viable development. Currently, many areas of the state affordable housing market are experiencing cash flow issues, especially New York City.

Further impacting on the analysis is that the rental rates (*Government Standards*) are generally below market standards causing the effective operating expense ratio to be **significantly higher**. This results in a substantially lower net operating income.

For valuation purposes, the housing development is highly restricted and has a higher investment risk. The effective market capitalization rate will increase by 150 to 300 basis points because of risk, limited long-term appreciation, and restrictions.

The actual gross rent is determined by a formula that is based on average median income for the area (*MSA or County*) and is adjusted annually based on this formula. Given the marginal growth of income in upstate New York, effective values for most affordable housing development could be significantly financially impaired in limited growth regions.

The 202 program is very similar to the RD 515 program, which also may effectively end as an on-going program soon. The long-term view on the future of the Low-Income Housing Tax Credit (*LIHTC*) program is not highly positive currently.

The statute has created areas of interest. Many assessors attempt to utilize Institutional Investment quality capitalization rate surveys as the basis of the market rate capitalization factor, but clearly affordable housing **is not** institutional quality investment.

The owners view the low rents and government restriction to result in marginally viable development. A further impact on the analysis is that the rental rates (*Government Standards*) are below market standards causing the effective operating expense ratio to be significantly higher than market rate projects. This results in a substantially lower net operating income.

In addition, Housing Community Renewal (HCR) has increased the quality and overall operating efficiency of affordable housing. This is to protect Housing Trust Investment and other related funding programs and results in significant increase in reserve requirements over market rate developments. For some development, the reserves are the second highest expense item.

Programs under Housing and Community Renewal (HCR) have a greater percentage of lower income units for seniors than many of the existing NYS-HFA developments. While both are serving the community, the newer HCR senior developments have less revenue.

Disclosure to the Users of this Report

We believe that the estimate is a reasonable reflection of the real estate taxes for 20242/2025 and is subject to your review and analysis of all revenues, expenses, and guidelines. We are submitting this report as part of our application.

However, the actual real estate taxes are based on the date the property enters service, the rents at that time (*HUD/NYS-HCR – formula*), estimate tenant utility allowances by unit type, actual expenses, mill rates and effective capitalization rates for similar properties.

This report does not in any way bind the assessor(s) to agree to our analysis. Other than that, the property is to be assessed under the standards of 581-(a)

The property operates in a heavily regulated environment. The operations of the property are subject to the administrative directives, rules and regulations of federal, state and local regulatory agencies, including, but not limited to, HUD, NYS-DCR, NYS-HFA, Rural Development and other State Housing Agency. Such administrative directives, rules and regulations are subject to change by an act of Congress, or an administrative change mandated by HUD or the State Housing Agency. Such changes may occur with little notice or inadequate funding to pay for the related cost, including the additional administrative burden, to comply with the changes.

Jurisdictional Exception Rule:

If any part of USPAP is contrary to the law or public policy of any jurisdiction, only that part shall be void and no force or effect in that jurisdiction. An appraiser using the **JURISDICTIONAL EXCEPTION RULE** must properly identify and comply with the law or regulation that precludes compliance with USPAP. In addition, the appraiser must disclose in the report the part of USPAP that is voided by that law and regulation, and also cite in the report the specific law or regulation that precludes compliance with USPAP

The valuation method as mandated by RPTL 581-a is only the income approach. This has created a *Jurisdictional Exception*, as noted in this report. 581a also requires that reserves be assumed to be an operating expense for analysis and calculation basis.

The 581a Stature

§ 581 Note 5

810, 534 N.Y.S.2d 938, 531 N.E.2d 658. Taxation \Leftrightarrow 2517; Taxation \Leftrightarrow 2521

6. Sales

Towns' appraisal and tax assessment of multiple dwelling condominium property associated with large, wilderness recreational retreat was erroneous and unsupported; towns' appraiser failed to consider value of condominiums sold in bona fide arms length market transactions; appraiser relied on the properties as potential timber resources, although property had always been used as wilderness retreat and was subject to conservation easement, and increase in value for waterfront property was based on four sales and resales, none of which were within the towns. *Bay Pond Condominiums v. Town of Waverly*, 2003, 195 Misc.2d 489, 760 N.Y.S.2d 298. Taxation \Leftrightarrow 2515; Taxation \Leftrightarrow 2518.

Recent sales of condominiums, if not extraordinary, lessen the need of the appraiser or the court to engage in speculation in making tax assessments. *Bay Pond Condominiums v. Town of Waverly*, 2003, 195 Misc.2d 489, 760 N.Y.S.2d 298. Taxation \Leftrightarrow 2515

7. Aggregate value

Where some, but not all, units in condominium complex were subject of petitions to reduce tax assessments, court could properly affix value to all units, in order to comply with statutory requirement that aggregate of unit valuations not exceed valuation of property as single parcel. *East Medical Center, L.P. v. Assessor of Town of Manlius* (4 Dept. 2005) 16 A.D.3d 1119, 791 N.Y.S.2d 778. Taxation \Leftrightarrow 2699(11)

Taxing authority must assess value of condominium unit as if it were rental property, but aggregate of unit valuations plus their common interests may not exceed valuation of property if it were being assessed as single, rent-producing unit. *East Medical Center, L.P. v. Assessor of Town of Manlius* (4 Dept. 2005) 16 A.D.3d 1119, 791 N.Y.S.2d 778. Taxation \Leftrightarrow 2478

§ 581-a. Assessment of residential real property

Notwithstanding any other provision of law, the assessed valuation of real property used for residential rental purposes where at least

408

ASSESSMENT PROCEDURE Art. 5

Taxing authority must assess value of condominium unit as if it were rental property, but aggregate of unit valuations plus their common interests may not exceed valuation of property if it were being assessed as single, rent-producing unit. *East Medical Center, L.P. v. Assessor of Town of Manlius* (4 Dept. 2005) 16 A.D.3d 1119, 791 N.Y.S.2d 778. Taxation \Leftrightarrow 2478

That assessed values of some condominiums approximated recent sales prices of those units was not enough, without more, to warrant inference that property tax assessments were derived solely or substantially from those prices, as basis for claim that values ascribed to individual units, taken together, exceeded value that would be assigned to property as single parcel, or that assessed values were greater than those that would be placed on property if it were merely conventional apartments. *Board of Managers of the Harbor Condominiums v. Board of Assessors of the Village of Lake Placid* (3 Dept. 1997) 238 A.D.2d 825, 656 N.Y.S.2d 531, leave to appeal denied 91 N.Y.2d 802, 667 N.Y.S.2d 682, 690 N.E.2d 491. Taxation \Leftrightarrow 2722

8. Apportionment of value

Where condominium complex consisted of both finished and unfinished units, court could properly utilize data from comparable condominium sales to appportion value of individual units, for tax assessment purposes. *East Medical Center, L.P. v. Assessor of Town of Manlius* (4 Dept. 2005) 16 A.D.3d 1119, 791 N.Y.S.2d 778. Taxation \Leftrightarrow 2515

9. Evidence, generally

Where condominium complex consisted of both finished and unfinished units, court could properly utilize data from comparable condominium sales to appportion value of individual units, for tax assessment purposes. *East Medical Center, L.P. v. Assessor of Town of Manlius* (4 Dept. 2005) 16 A.D.3d 1119, 791 N.Y.S.2d 778. Taxation \Leftrightarrow 348(3)

MISCELLANEOUS PROVISIONS Title 4

§ 581-b

Twenty percent of the residential units are subject to an agreement with a municipality, the state, the federal government, or an instrumentality thereof, which agreement restricts occupancy of those units to tenants who qualify in accordance with an income test, shall be determined using the income approach as applied to the actual net operating income, after deducting for reserves required by any federal, state or municipal programs. For the purposes of this section "net operating income" shall mean the actual or anticipated net income that remains after all operating expenses are deducted from effective gross income, but before mortgage debt service and book depreciation are deducted. The assessed valuation of real property used for such residential rental purposes shall be determined using the actual net operating income, and shall not include federal, state or municipal income tax credits, subsidized mortgage financing, or project grants, where such subsidies are used to offset the project development cost in order to provide for lower initial rents as determined by regulations promulgated by the division of housing and community renewal.

Added L.2005, c. 714, § 1, eff. Oct. 11, 2005.)

Historical and Statutory Notes

L.2005, c. 714 legislation status dates occurring on or after the first of January next succeeding the date on which it shall take effect immediately (Oct. 11, 2005) and shall apply to taxable

Library References

Municipal Corporations \Leftrightarrow 972.
Taxation \Leftrightarrow 2478, 2521.
Westlaw Topic Nos. 268, 371.
C.J.S. Municipal Corporations §§ 1783, 1786 to 1794.

Research References

Encyclopedias
NY Jur. 2d, Taxation & Assessment § 338, Residential Rental Property.

§ 581-b. Assessment of parcels used for residential purposes and registered as family day care homes

Notwithstanding any inconsistent provision of law, in the assessment of any parcel used for residential purposes and registered as a family day care home pursuant to section three hundred ninety of the social services law, the use or registration of such parcel as a family day care home shall be completely disregarded in assessing the value of such parcel.

Added L.2006, c. 319, § 2, eff. July 26, 2006.)

409

Valuation Analysis of the 581(a)

Year 2025

Calculation of 581a – Real Estate Taxes – New York

| The Green Apt Newburgh, NY 581-a Analysis -revised | 122 | 122 | 122 | 122 | 122 |
|---|-------------------------|---------------------|------------------------|--------------------------|-------------------------|
| | Valuation Conclusion | Base Case One | Chg of Cap Rate Two | Chg of Cap Rate Three | Chg of Cap Rate Four |
| Total Revenue 100% | 2,112,000 | 2,112,000 | 2,112,000 | 2,112,000 | 2,112,000 |
| Vacancy Factor - 3.00% | (63,360) | (63,360) | (63,360) | (63,360) | (63,360) |
| Adjusted Revenue | 2,048,640 | 2,048,640 | 2,048,640 | 2,048,640 | 2,048,640 |
| Adminstration | 33,630 | 33,630 | 33,630 | 33,630 | 33,630 |
| Payroll and Related | 190,000 | 190,000 | 190,000 | 190,000 | 190,000 |
| Repairs and related | 244,000 | 244,000 | 244,000 | 244,000 | 244,000 |
| Water & Sewer | 58,520 | 58,520 | 58,520 | 58,520 | 58,520 |
| Utilities | 130,602 | 130,602 | 130,602 | 130,602 | 130,602 |
| Elevator | 7,000 | 7,000 | 7,000 | 7,000 | 7,000 |
| Insurance | 92,000 | 92,000 | 92,000 | 92,000 | 92,000 |
| Management fee | 160,308 | 160,308 | 160,308 | 160,308 | 160,308 |
| Total Expenses | 916,060 | 916,060 | 916,060 | 916,060 | 916,060 |
| Required Reserves | 36,600 | 36,600 | 36,600 | 36,600 | 36,600 |
| Operating Expenses | 952,660 | 952,660 | 952,660 | 952,660 | 952,660 |
| Adjusted Cash Flow | 1,095,980 | 1,095,980 | 1,095,980 | 1,095,980 | 1,095,980 |
| Equalization Rate | 100% | 100% | 100% | 100% | 100% |
| Mill Rates per \$1,000 | | | | | |
| County tax - Orange Cty | 2.009620 | 2.009620 | 2.009620 | 2.009620 | 2.009620 |
| Newburgh City | 14.630390 | 14.630390 | 14.630390 | 14.630390 | 14.630390 |
| School | 12.869339 | 12.869339 | 12.869339 | 12.869339 | 12.869339 |
| Library | 0.679345 | 0.679345 | 0.679345 | 0.679345 | 0.679345 |
| Other | 0.000000 | 0.000000 | 0.000000 | 0.000000 | 0.000000 |
| Total Mill Rates | 30.188694 | 30.188694 | 30.188694 | 30.188694 | 30.188694 |
| Adjusted Mill Rates | 30.1887 | 30.1887 | 30.1887 | 30.1887 | 30.1887 |
| Market Cap Rate | | | | | |
| Standard Rate | 9.50% | 9.00% | 8.50% | 8.00% | 7.50% |
| Adjustment - restrictions | 0.00% | 0.00% | 0.00% | 0.00% | 0.00% |
| Aadjusted Market Cap rate | 9.50% | 9.00% | 8.50% | 8.00% | 7.50% |
| Assessor Cap Rate | | | | | |
| Adjusted Market Cap rate | 9.5000% | 9.0000% | 8.5000% | 8.0000% | 7.5000% |
| Total Mill Rate | 3.0189% | 3.0189% | 3.0189% | 3.0189% | 3.0189% |
| Aessor's Cap Rate | 12.5189% | 12.0189% | 11.5189% | 11.0189% | 10.5189% |
| Concluded Value | \$ 8,754,624 | \$ 9,118,828 | \$ 9,514,649 | \$ 9,946,393 | \$ 10,419,181 |
| Value per unit | \$ 71,759 | \$ 74,744 | \$ 77,989 | \$ 81,528 | \$ 85,403 |
| Real Estate Taxes | | | | | |
| County tax - Orange Cty | \$ 17,593.47 | \$ 18,325.38 | \$ 19,120.83 | \$ 19,988.47 | \$ 20,938.59 |
| Newburgh City | \$ 128,083.57 | \$ 133,412.01 | \$ 139,203.03 | \$ 145,519.60 | \$ 152,436.68 |
| School | \$ 112,666.23 | \$ 117,353.29 | \$ 122,447.24 | \$ 128,003.50 | \$ 134,087.97 |
| Library | \$ 5,947.41 | \$ 6,194.83 | \$ 6,463.73 | \$ 6,757.03 | \$ 7,078.22 |
| Other | \$ - | \$ - | \$ - | \$ - | \$ - |
| Total Real Estate taxes | \$ 264,290.68 | \$ 275,285.50 | \$ 287,234.83 | \$ 300,268.60 | \$ 314,541.45 |
| Per Unit - RET | \$ 2,166.32 | \$ 2,256.44 | \$ 2,354.38 | \$ 2,461.22 | \$ 2,578.21 |
| Operating Expenses | 952,660 | 952,660 | 952,660 | 952,660 | 952,660 |
| Per Unit - RET | 264,291 | 275,286 | 287,235 | 300,269 | 314,541 |
| Total Expenses | 1,216,951 | 1,227,946 | 1,239,895 | 1,252,929 | 1,267,201 |
| Expenses -% Revenue | 59.40% | 59.94% | 60.52% | 61.16% | 61.86% |
| Taxes - % Revenue | 12.90% | 13.44% | 14.02% | 14.66% | 15.35% |
| Taxes - % Expenses | 21.72% | 22.42% | 23.17% | 23.97% | 24.82% |

Income Approach to Valuation:

The Income Approach is defined as,

"a set of procedures in which an appraiser derives a value indication for income producing property by converting anticipated benefits into property value. This conversion is accomplished either by:

- o Capitalizing a single-year's income expectancy or an annual average of several years' income expectancies at a market-derived capitalization rate or a capitalization rate that reflects a specified income pattern return on investment, and change in the value of the investment.

- o Discounting the annual cash flows for the holding period and the reversion at a specified yield rate."

The Income Approach views the property as a revenue producing asset whose value is dependent upon its ability to satisfy investment criteria. The general steps include:

- o Understanding the revenue producing potential of the property.

- o Considering appropriate expenses including a vacancy and rent loss factor as well as normal recurring operating expenses and real estate taxes. A careful study is undertaken to insure the level of operating expenses represents typical management.

- o Subtracting periodic operating expenses from anticipated revenues results in a net operating income stream. Then, deducting capital expenditures results in a pretax cash flow.

Under S-581-a. *ASSESSMENT OF RESIDENTIAL REAL PROPERTY* provides for net operating income to be reduced by required reserve requirements.

After, we have calculated the adjusted Net Operating Income (NOI), we are required to divide the adjusted Net Operating Income by a calculated capitalization rate to determine the assessed value of the property. I also reviewed comparable affordable family developments for operating expenses. I only adjusted payroll and related by increasing by \$24,000 to reflect an additional part-time employee.

Before I can finalize the overall rate, I need to calculate and include an effective tax rate. I used the rate supply to me by the assessor's records

I have not deducted the actual tax bill as an operating expense because the proper real estate taxes are still unknown. This is because real estate taxes are based on the property value, which we have not yet calculated.

In concluding the final capitalization rate for the value conclusion, I will add the market capitalization rate and the real estate tax capitalization rate.

Generally, the assessor is applying only a zero percent contingency factor on actual operating revenues that is based on 581a standards for actual operating properties. . However, most state agencies for housing are using 5% to 7% as a standard.

The property cash flow is based on 100% revenue for analysis purposes. Given standard tenant turnover, the actual percentage varies from 2.5% to 5.00%. I have concluded a 3.00% factor

Valuation Analysis of the 581(a)

Year 2025

Analysis of Revenues

//

| | | | | | |
|-------------------------|--|-------------------------|--|------------|--|
| Project Name: The Green | | HFA Project # (ProLink) | | Units: 122 | |
| Orange County | | | | | |

| UNITS & INCOME | | | | | |
|-------------------|-----|------------|--------------|------------|------------------------------|
| UNIT DISTRIBUTION | | | | | |
| | Mix | # of Units | # of Rms/ DU | # Rooms | PLEASE INPUT Avg. NSF/ DU |
| Studio | 3% | 4 | 2 | 8 | 580 |
| 1BR | 65% | 79 | 3 | 237 | 743 |
| 2BR | 27% | 33 | 4 | 132 | 944 |
| 3BR | 4% | 5 | 5 | 25 | 1,161 |
| 4BR | 0% | 0 | 6 | 0 | |
| Subtotal | | 121 | | 402 | |
| Super's Unit | | 1 | 4 | 4 | |
| Total | | 122 | | 406 | 97,974 |

| SF DISTRIBUTION | | | |
|-----------------|----------------|--------------------------|----------------|
| | GSF | Efficiency | NSF |
| 96.26% | 144,246 | Residential GSF 97% | 140,009 |
| 3.74% | 5,612 | Commercial GSF 95% | 5,328 |
| 0.00% | | Community GSF | 0 |
| 0.00% | | Parking GSF | 0 |
| | 149,858 | Total Project GSF | 145,338 |
| Lot SF: | 40,075 | | |

| COMMERCIAL AND ANCILLARY INCOME | | | |
|--|-------------|------------------|---|
| | # of Spaces | Monthly per unit | Annual Income |
| Parking | 42 | \$ - | \$0 |
| Total s.f. Annual Rent / Per SF | | | |
| Commercial | 5,612 | \$ 8 | \$44,896 |
| Community Facility | 0 | | \$0 |
| | # units | Annual per unit | |
| Laundry | 122 | \$ 110 | \$13,420 |
| Total Commercial & Ancillary Income | | | \$58,316 2.76% (% of total income) |

| RESIDENTIAL INCOME UPON OCCUPANCY | | | | | | | | | | | | |
|-------------------------------------|-------|----------------------------------|-----------------|--------------------|---------------------------|------------|-------------------------|------------------|-------------------|----------|---------------------|----------------------------|
| Unit size | Rooms | Qualified HH Income Limit (AMI)* | Number of Units | Tax Credit Program | Rental Assistance Program | Gross Rent | Rent per Applicable AMI | Underwritten AMI | Utility Allowance | Max Net | Annual Rent | |
| Studio | 2 | 40% | 1 | LIHTC & SLIHC | | \$ 861 | \$ 861 | 40% | \$ 68 | \$ 793 | \$ 9,516 | |
| 1BR | 3 | 40% | 23 | LIHTC & SLIHC | | \$ 922 | \$ 923 | 40% | \$ 79 | \$ 843 | \$ 232,668 | |
| 2BR | 4 | 40% | 10 | LIHTC & SLIHC | | \$ 1,107 | \$ 1,107 | 40% | \$ 87 | \$ 1,020 | \$ 122,400 | |
| 3BR | 5 | 40% | 1 | LIHTC & SLIHC | | \$ 1,279 | \$ 1,280 | 40% | \$ 95 | \$ 1,184 | \$ 14,208 | |
| 4BR | 6 | 40% | | LIHTC & SLIHC | | | \$ 1,476 | 0% | | \$ - | \$ - | |
| Studio | 2 | 60% | 1 | LIHTC & SLIHC | | \$ 1,291 | \$ 1,291 | 60% | \$ 68 | \$ 1,223 | \$ 14,676 | |
| 1BR | 3 | 60% | 26 | LIHTC & SLIHC | | \$ 1,383 | \$ 1,384 | 60% | \$ 79 | \$ 1,304 | \$ 406,848 | |
| 2BR | 4 | 60% | 10 | LIHTC & SLIHC | | \$ 1,660 | \$ 1,660 | 60% | \$ 87 | \$ 1,573 | \$ 188,760 | |
| 3BR | 5 | 60% | 1 | LIHTC & SLIHC | | \$ 1,919 | \$ 1,920 | 60% | \$ 95 | \$ 1,824 | \$ 21,888 | |
| 4BR | 6 | 60% | | LIHTC & SLIHC | | | \$ 2,214 | 0% | | \$ - | \$ - | |
| Studio | 2 | 80% | 1 | LIHTC & SLIHC | | \$ 1,593 | \$ 1,722 | 74% | \$ 68 | \$ 1,525 | \$ 18,300 | |
| 1BR | 3 | 80% | 23 | LIHTC & SLIHC | | \$ 1,729 | \$ 1,846 | 75% | \$ 79 | \$ 1,650 | \$ 455,400 | |
| 2BR | 4 | 80% | 10 | LIHTC & SLIHC | | \$ 2,062 | \$ 2,214 | 75% | \$ 87 | \$ 1,975 | \$ 237,000 | |
| 3BR | 5 | 80% | 1 | LIHTC & SLIHC | | \$ 2,395 | \$ 2,560 | 75% | \$ 95 | \$ 2,300 | \$ 27,600 | |
| 4BR | 6 | 80% | | LIHTC & SLIHC | | | \$ 2,952 | 0% | | \$ - | \$ - | |
| Studio | 2 | 100% | 1 | None | | \$ 1,718 | \$ 2,152 | 80% | \$ 68 | \$ 1,650 | \$ 19,800 | |
| 1BR | 3 | 100% | 7 | None | | \$ 1,854 | \$ 2,307 | 80% | \$ 79 | \$ 1,775 | \$ 149,100 | |
| 2BR | 4 | 100% | 3 | None | | \$ 2,212 | \$ 2,767 | 80% | \$ 87 | \$ 2,125 | \$ 76,500 | |
| 3BR | 5 | 100% | 2 | None | | \$ 2,570 | \$ 3,200 | 80% | \$ 95 | \$ 2,475 | \$ 59,400 | |
| 4BR | 6 | 100% | | None | | | \$ 3,690 | 0% | | \$ - | \$ - | |
| Total Annual Rental Income | | | | | | | | | | | \$ 2,054,064 | |
| Total Revenue units | | | | | | | | | | | 121 | LIHTC Applicable Fraction: |
| Total LIHTC units | | | | | | | | | | | 108 | 88.84% |
| Total SLIHC units | | | | | | | | | | | 108 | |
| Total Revenue NSF | | | | | | | | | | | 97,974 | SLIHC Applicable Fraction: |
| Total LIHTC NSF | | | | | | | | | | | 87,039 | 88.84% |
| Total SLIHC NSF | | | | | | | | | | | 87,039 | |
| TOTAL ANNUAL PROJECT INCOME: | | | | | | | | | | | \$ 2,112,380 | |

| SUMMARY | | |
|--------------|------------|-----|
| AMI Tier | # D/Us | |
| 30% | 0 | 0% |
| 40% | 35 | 29% |
| 50% | 0 | 0% |
| 60% | 38 | 31% |
| 70% | 0 | 0% |
| 80% | 35 | 29% |
| 90% | 0 | 0% |
| 100% | 13 | 11% |
| 110% | 0 | 0% |
| 120% | 0 | 0% |
| 130% | 0 | 0% |
| 140% | 0 | 0% |
| 150% | 0 | 0% |
| 160% | 0 | 0% |
| 165% | 0 | 0% |
| Market | 0 | 0% |
| Total | 121 | |

| LIHTC INCOME AVERAGING SET-ASIDE | |
|---|----------------------|
| 60% | Average LIHTC Income |
| Income Averaging projects should have a maximum average income below 60%. | |

| ESSHI Award | |
|------------------------------|----------|
| ESSHI units | 0 |
| ESSHI individuals | 0 |
| ESSHI Award Per Unit | \$25,000 |
| Total ESSHI Award | \$0 |
| Average Tenant Contribution | \$0 |
| Operations/Rental Allocation | #DIV/0! |
| Services Allocation | #DIV/0! |

*Include a note in Rental Assistance Program column if applicable.

Valuation Analysis of the 581(a)

Year 2025

Operating Expense Analysis

| | | | | | | |
|--|--|---------------------------------|-----------------|--|---|-----------------------------------|
| Project Name: The Green | | Units | 122 | | | |
| Orange County | | Rooms | 406 | | | |
| MAINTENANCE & OPERATING EXPENSES | | | | | | |
| <i>Please add/modify categories as needed:</i> | | | | | | |
| | Comments | Expenses/ Unit | Expenses/ Room | Two Year Old Financial Statement <small>(preservation only)</small> | Last Year's Financial Statement <small>(preservation only)</small> | Borrower Projected Expenses |
| Tax & Insurance | | | | | | |
| Real Estate Taxes | | \$1,440 | \$433 | | | \$175,700 |
| Insurance | | \$754 | \$227 | | | \$92,000 |
| | Subtotal | \$2,194 | \$659 | | | \$267,700 |
| Administrative | | | | | | |
| Professional Fees | | \$38 | \$11 | | | \$4,600 |
| Accounting | | \$153 | \$46 | | | \$18,610 |
| Office Supplies/Equipment | | \$38 | \$11 | | | \$4,650 |
| Phone Lines/Fire Alarms | | \$42 | \$13 | | | \$5,170 |
| Benchmarking | | \$5 | \$1 | | | \$600 |
| Manager | | \$492 | \$148 | | | \$60,000 |
| | Subtotal | \$767 | \$231 | | | \$93,630 |
| Management Fee | | | | | | |
| | | \$1,314 | \$395 | | | \$160,308 |
| Utilities | | | | | | |
| Heating | <i>Electric</i> | \$455 | \$137 | | | \$55,522 |
| Electricity (common areas) | | \$375 | \$113 | | | \$45,800 |
| Gas (cooking) (preservation only) | | \$0 | \$0 | | | |
| Water/Sewer | | \$480 | \$144 | | | \$58,520 |
| Broadband Internet | | \$240 | \$72 | | | \$29,280 |
| | Subtotal | \$1,550 | \$466 | | | \$189,122 |
| Repairs and Maintenance | | | | | | |
| Supplies/Cleaning/Exterminating | | \$381 | \$115 | | | \$46,525 |
| Landscaping/Snow Removal | | \$576 | \$173 | | | \$70,305 |
| Repairs/Replacement | | \$661 | \$199 | | | \$80,645 |
| Superintendent & Maintenance Staff Salaries including Benefits | | \$869 | \$261 | | | \$106,000 |
| | Super | <i>Salaries</i> \$58,000 | <i>No.</i> 1 | | | |
| | Porter | \$48,000 | 1 | | | |
| Elevator Maintenance and Repairs | | \$57 | \$17 | | | \$7,000 |
| | | <i>Cost/Elevator</i> \$7,000 | <i>No.</i> 1 | | | |
| | Subtotal | \$2,545 | \$765 | | | \$310,475 |
| Total Operating Expenses | | \$8,371 | \$2,515 | | | \$1,021,235 |
| Total Expenses Net of Management Fee | | \$7,057 | \$2,121 | | | \$860,927 |
| Reserves | | | | | | |
| Replacement Reserves | <i>\$300/du = NC, \$350/du = Pres.</i> | \$300 | \$90 | | | \$36,600 |
| | Subtotal | \$300 | \$90 | | | \$36,600 |
| Total Operating Expenses and Reserves | | \$8,671 | \$2,606 | | | \$1,057,835 |

Capitalization Rate Development

The development of a real estate value under RPTL 581-a is relatively straight forward. The value is determined by actual revenues and expenses divided by a defined assessor's formula for the capitalization rate. The capitalization rate is based on three major factors:

- (1) Perceived Risk
- (2) Appreciation Expectations
- (3) Required Returns in alternative investment vehicles

Capitalization Rate Analysis Method

The capitalization of Net Operating Income (NOI) before and after reserves is a very gray area in the appraisal industry. The one factor is that the appraiser must be consistent in the application of its use. I always capitalized before reserves. In support of my view is the following:

- 1. Capitalization rates from sales comparable are based usually on NOI before reserves.
- 2. Reserves could be a major asset in some projects, and we should not treat it like a long-term liability.

However, the 581-a statute requires reserves to be deducted.

Development of The Assessor's Capitalization Rate

The Assessor's Capitalization rate consists of two rates. The first is the market rate, which is from the market rate or affordable sales data, if available. The second is the effective tax rate or ratio %, which is the sum of the mill rates (County, Town, School, Etc.)

Market Rate Capitalization Rate (+) Effective Tax Rate or Ratio %

Equals (=)

The Assessor's Capitalization Rate

The statute has created areas of interest. Many assessors attempt to utilize Institutional Investment quality capitalization rate surveys as the basis of the market rate capitalization factor, but clearly affordable housing **is not** institutional quality investment.

Capitalization Rate Survey

The RealtyRates.com™ quarterly **Investor Survey** includes national mortgage terms and interest rates, equity requirements, cap and discount rates, reserve requirements, and interim financing rates and terms for [32 income producing property types](#), plus financial indicators, historical cap rate trend data, and land lease cap and discount rates, likewise by property type.

The actual process of collection from our third-party sources is via online forms subsequently downloaded into Excel, converted to graphics and published to the Internet in HTML and PDF formats. Robert. G. Watts / RealtyRates.com™ conducts no data analysis itself, but rather collects, collates and presents the data for you to use in your own analyses. Likewise, we provide very limited commentary and offer virtually no prognostications, although the built-up overall cap rates in the *Investor Survey* tend to be forward-looking.

With 10 years on the Web, The RealtyRates.com™ serves more than 4,000 companies, government agencies, universities and individuals in all U. S. states and territorial possessions and more than 25 other countries. The Surveys are utilized as collateral material in more than 60 college and university programs including eight overseas, as well as by several trade and professional organizations including the CCIM Institute and IREM Institute of Real Estate Management. Survey extracts are included in three college texts as well as numerous published articles, monographs and scholarly reports

| RealtyRates.com INVESTOR SURVEY - 3rd Quarter 2023* | | | | | | |
|---|----------|-------------------------------------|------|----------|----------|--------------|
| APARTMENTS - GARDEN/SUBURBAN TOWNHOUSE | | | | | | |
| Item | Input | | | | | OAR |
| Minimum | | | | | | |
| Spread Over 10-Year Treasury | 0.75% | DCR Technique | 1.00 | 0.052567 | 0.90 | 4.73 |
| Debt Coverage Ratio | 1.00 | Band of Investment Technique | | | | |
| Interest Rate | 4.32% | Mortgage | 90% | 0.052567 | 0.047310 | |
| Amortization | 40 | Equity | 10% | 0.047040 | 0.004704 | |
| Mortgage Constant | 0.052567 | OAR | | | | 5.20 |
| Loan-to-Value Ratio | 90% | Surveyed Rates | | | | 4.89 |
| Equity Dividend Rate | 4.70% | | | | | |
| Maximum | | | | | | |
| Spread Over 10-Year Treasury | 3.65% | DCR Technique | 1.61 | 0.109341 | 0.65 | 11.44 |
| Debt Coverage Ratio | 1.61 | Band of Investment Technique | | | | |
| Interest Rate | 7.22% | Mortgage | 65% | 0.109341 | 0.071071 | |
| Amortization | 15 | Equity | 35% | 0.125446 | 0.043906 | |
| Mortgage Constant | 0.109341 | OAR | | | | 11.50 |
| Loan-to-Value Ratio | 65% | Surveyed Rates | | | | 10.81 |
| Equity Dividend Rate | 12.54% | | | | | |
| Average | | | | | | |
| Spread Over 10-Year Treasury | 2.20% | DCR Technique | 1.26 | 0.072612 | 0.78 | 7.06 |
| Debt Coverage Ratio | 1.26 | Band of Investment Technique | | | | |
| Interest Rate | 5.77% | Mortgage | 78% | 0.072612 | 0.056275 | |
| Amortization | 28 | Equity | 23% | 0.082323 | 0.018523 | |
| Mortgage Constant | 0.072612 | OAR | | | | 7.48 |
| Loan-to-Value Ratio | 78% | Surveyed Rates | | | | 7.56 |
| Equity Dividend Rate | 8.23% | | | | | |

Given the subject is a lower income development with restrictions, the market standard capitization rate will need to be increased by 100 to 150 basis points. The standard rates for occupied apartment complex is 6.5% to 8.5%. Generally, proposed developments have increase risks and a higher cape,rate.. Our conclusion to subject capitization rate indcates a range from 8..5% to 9.5%. I have concluded a rate of 9.50%, given the status and location.

Final Reconciliation – Market Value

Final reconciliation is the application of the process of evaluation. Choice and selection of the indications of value derived from each of the approaches are utilized in the appraisal at hand to arrive at the final estimate of value.

The Cost Approach: The cost approach does not represent the market dynamics for the valuation of the property. The valuation method as mandated by RPTL 581-A is only the income approach. This has created a Jurisdictional Exception, as noted in this report.

The Market Approach: The Market Approach to value presents sales of properties considered comparable to the appraised property. In arriving at a value indication, I have not analyzed sales of comparable apartments complexes located in the surrounding area.

However, the valuation method as mandated by the RPTL 581-A is only the income approach. This has created a Jurisdictional Exception, as noted in this report.

The Income Approach: The income methodology involves the capitalization of an estimated stabilized net operating income for the property, by a market derived overall rate or discounting of the income stream by market derived rates. The direct capitalization method is utilized since buyers usually will obtain third party financing and the rates provide a sufficient adjustment range to provide a basic level for underwriting the loan. The valuation method as mandated by RPTL 581-A is only the income approach.

The subject property is appraised to estimate its market value, in a fee simple interest, as of March 26, 2026. After carefully considering supply and demand factors influencing the property, and transactions of competitive properties, I conclude the Market Value with 2025 rents and expenses of the fee simple interest of the Green Apartments, as of March 26, 2026, as follows:

Eight Million Seven Hundred Fifty Thousand Dollars
\$8,750,000 - \$71,800+/- per unit

Estimated Assessment Value

The assessment of the property is as follows based on equalization rate of 100%. This concludes an assessment amount of \$8,750,000, which indicates real estate taxes of \$264,000.

As discussed in the report the projected real estate taxes did vary from 264,000 to \$300,000 based on various assumptions, conditions, and terms.

Valuation Analysis of the 581(a)

Year 2025

Property Name: An assemblage Site – Three parcels - The Green Apartments

Location: City of Newburgh, Orange County, New York

Address 140 & 146 Montgomery Street , Newburgh, New York 12550
137 Smith Street Newburgh, New York 12550

Owner of Record

| Property | Tax Number | Owner | Book/ Page | Date of Sale |
|-----------------------|------------|------------------|------------|--------------|
| 140 Montgomery Street | 12-4-10 | City of Newburgh | 13076/1034 | Oct 2010 |
| 146 Montgomery Street | 12-4-2.1 | City of Newburgh | 13078/1034 | Oct 2020 |
| 137 Smith Street | 12-4-4.1 | City of Newburgh | 12814/1203 | Feb 2009 |
| | | | | |

Client: Kearney Realty & Development Group, Inc.

Type of Report Appraisal Report -561(A)

Date of Report March 31, 2026

Date of Appraisal March 26, 2026

Hypothetical Condition Yes: The analysis assumes an operating commercial property. The existing site is vacant development site

Extraordinary Assumptions Assumes that all sites will be legally assembled into one ownership. The Yes: building will be constructed and property will be leased.

Property Rights Fee Simple (as is)

Intended Users City of Newburgh, New York

Acquisition \$200,000

Highest & Best Use Affordable Rental Housing - 122 units

Property Vacant Los – Three Lots

Improvements None

Area Overview The City of Newburgh is the largest city in the County of Orange and has the lowest household income. The city has one of the largest areas of historic houses in the region. Newburgh is a working-class neighborhood of the Hudson Valley, and most residents are renters.

Census Tract 4.00 - please see pages 30 and 31

Area

| Property | Tax Number | Area SF | Zoning | Site Class |
|-----------------------|------------|------------|--------|------------|
| 140 Montgomery Street | 12-4-10 | 25,258 | WG | 311 |
| 146 Montgomery Street | 12-4-2.1 | 17,835 | WG | 311 |
| 137 Smith Street | 12-4-4.1 | 14,388 | WG | 311 |
| | | 57,481 +/- | | |

Flood Plain No – see page 16

Valuation Analysis of the 581(a)

Year 2025

Assessment

| Property | Tax Number | Assessment | Ass/factor (%) | If market |
|-----------------------|------------|------------|----------------|-----------|
| 140 Montgomery Street | 12-4-10 | \$132,000 | 100% | \$132,000 |
| 146 Montgomery Street | 12-4-2.1 | \$123,200 | 100% | \$123,200 |
| 137 Smith Street | 12-4-4.1 | \$67,800 | 100% | \$67,800 |
| | | \$323,000 | | \$323,000 |

Real Estate Taxes None – City of Newburgh owned

Utilities: Electric, cable, telephone, gas, and water

Road Frontage Road Frontage on South Street, Montgomery Street and Smith Street

Location The neighborhood is a low-income area with a high rate of 75[^] renters

Market Trends The demand for low-income and affordable housing is increasing.

The Town of Newburgh is significantly a higher income area than the City of Newburgh

Household Median Income – City- \$61,831
Household Income – Town- \$105,789

Median Priced Housing – City \$246,838
Median Price housing – Town \$404,843

Wetland Not apparent per review of map – see page 16

Site Plan Note Proposed apartment building

Valuation Conclusion and Analysis – AS IS

| | |
|-------------------------------|--------------------|
| Cost Approach | <i>n/a</i> |
| Market Approach | <i>n/a</i> |
| Income Approach | <i>n/a</i> |
| Final Value Conclusion | \$8,750,000 |
| Exposure Time Estimate | <i>n/a</i> |
| Marketing Time Est | <i>n/a</i> |

View of Proposed Improvements – 122 units

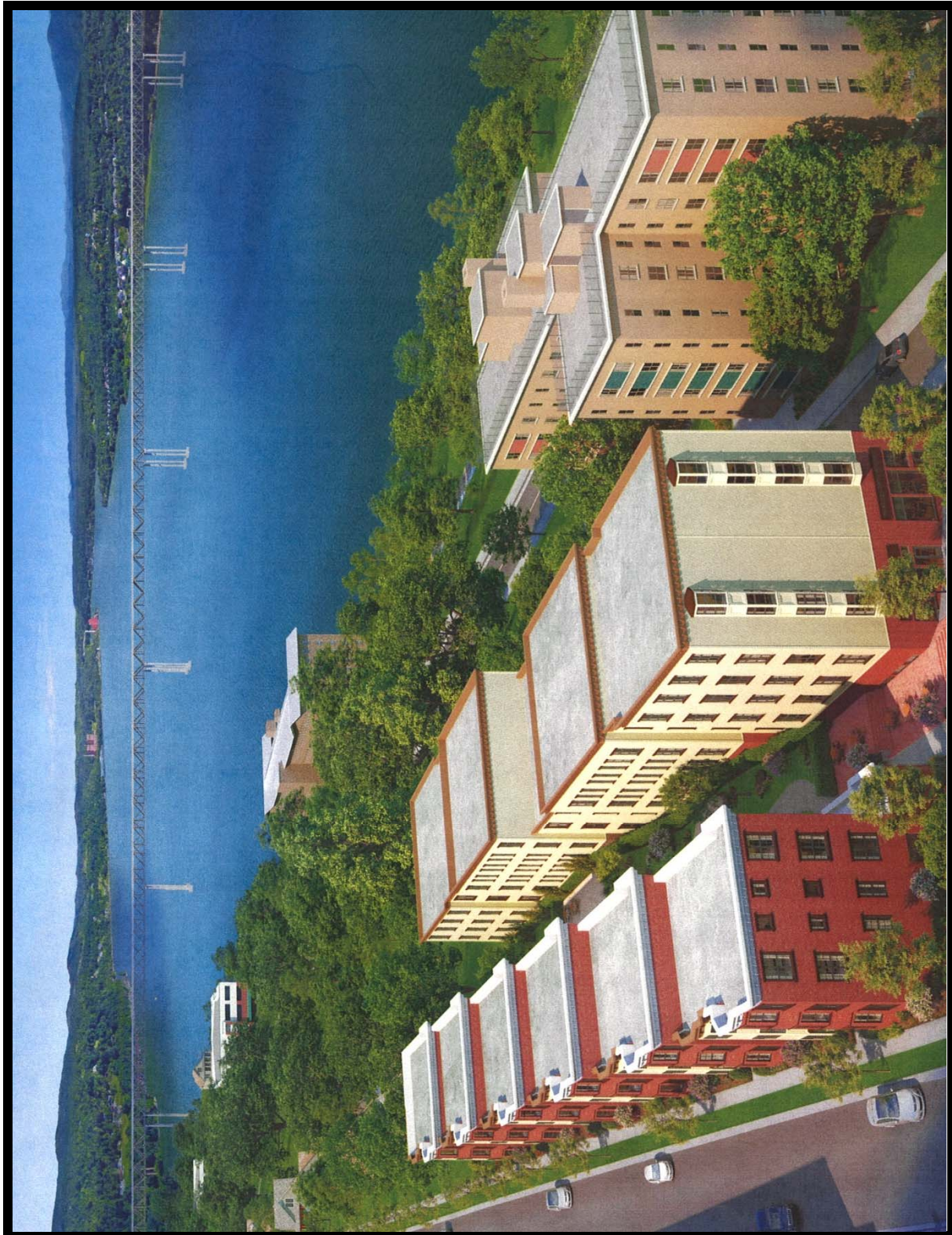

Valuation Analysis of the 581(a)

Year 2025

Tax Parcel Map – Three Parcels 140, 146 and 137

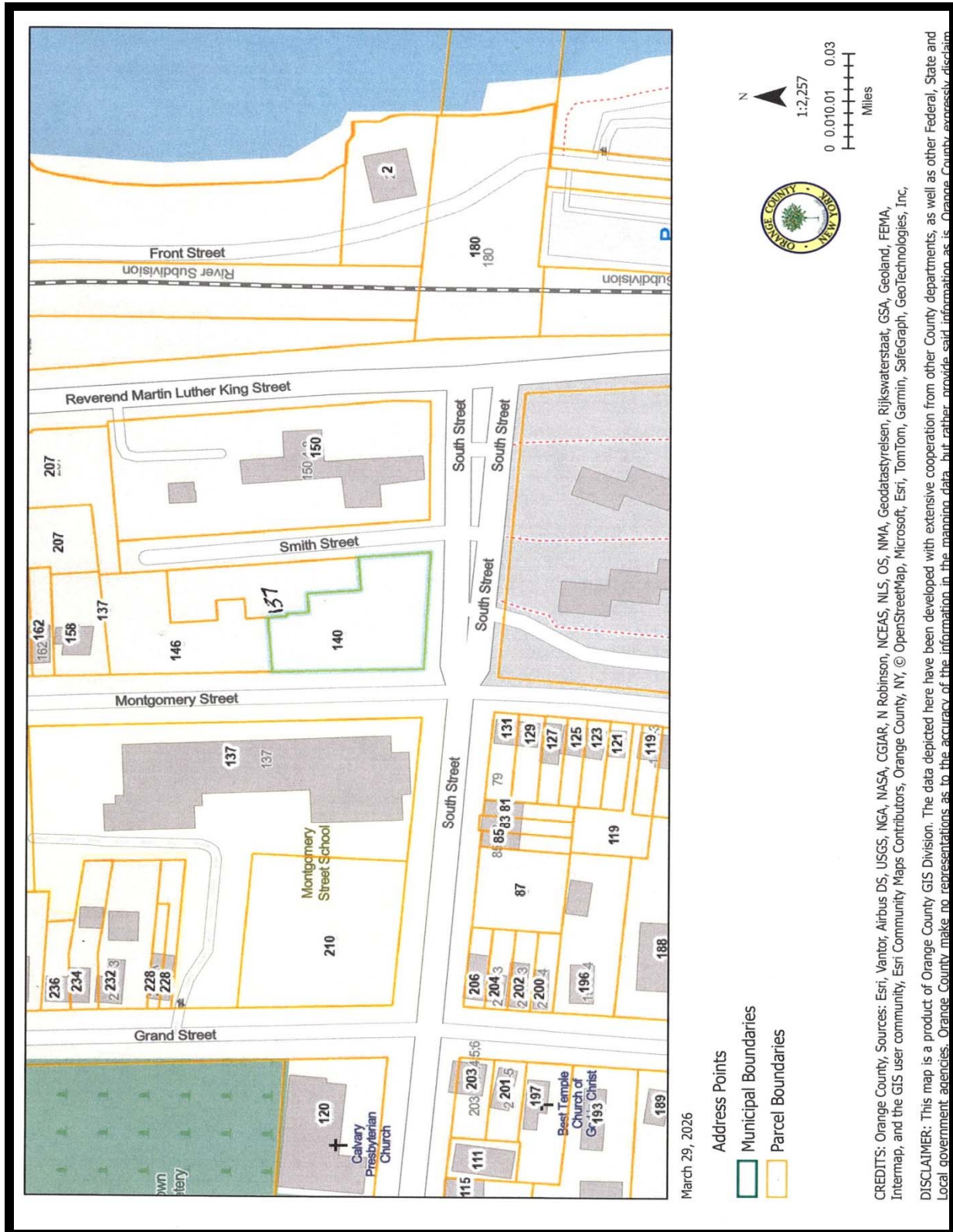

Valuation Analysis of the 581(a)

Year 2025

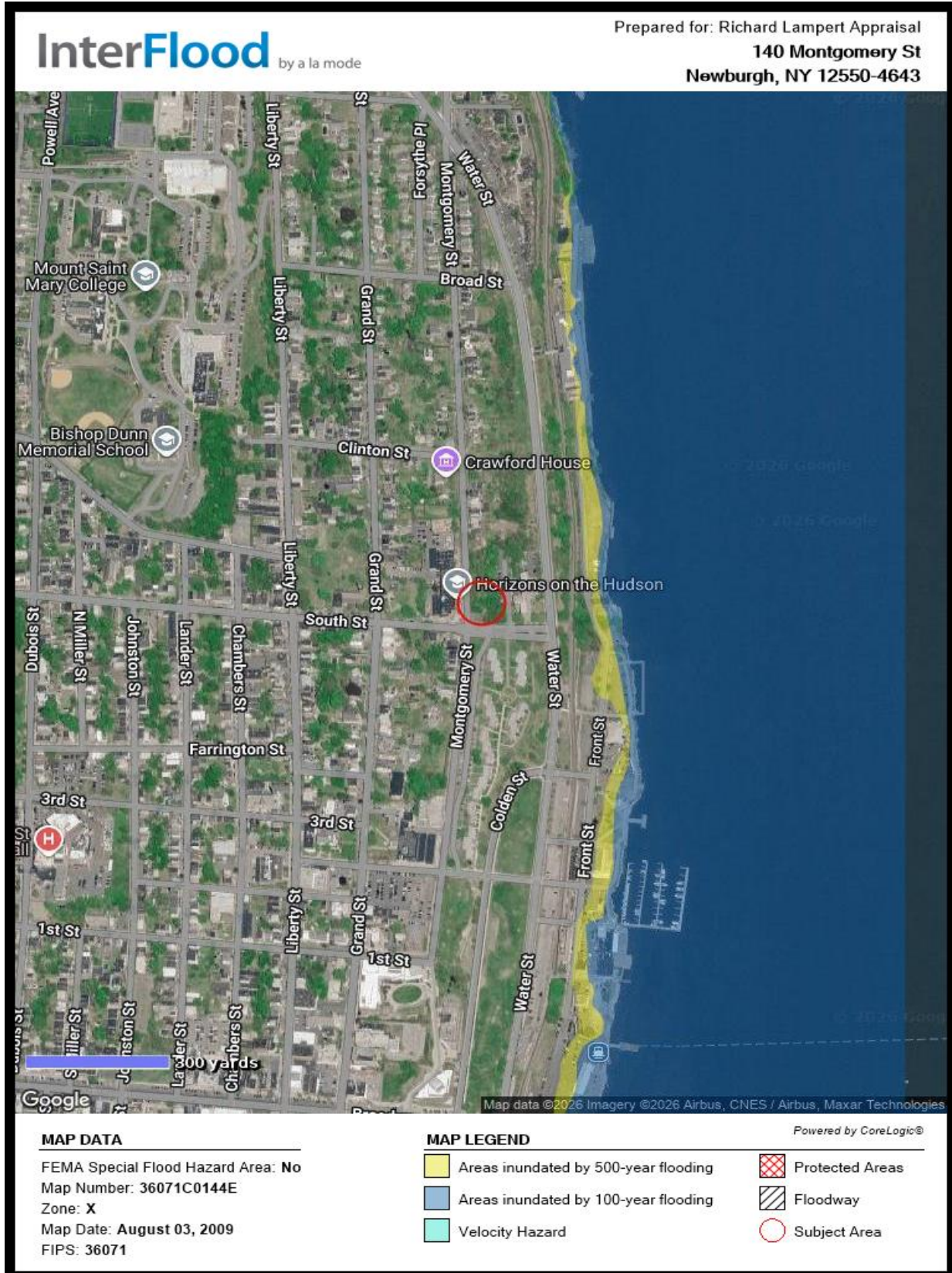

Valuation Analysis of the 581(a)

Year 2025

Upper: West side of property - Looking north
Lower: East side of property - Looking north



Valuation Analysis of the 581(a)

Year 2025

Upper: Looking South on Montgomery Street - Subject property to the left
Lower Looking south on South Street – Subject property to the left



Market Area Analysis - City of Newburgh

The city's population has continued to increase during the last twenty years by immigration and limited internal growth. The City of Newburgh has a population (2025) of over 28,760 persons in over 10,000 households. The median household income is \$61,831 and average household income is \$68,048. The median house value is \$246,838 and average value is \$329,155. The City of Newburgh has the highest unemployment rates in the county. The city has one of the largest areas of historic houses in the region. The city is mainly a renter community with 27% of population are owners, 61% are renters, and 12% is vacant non-occupied housing.

The City of Newburgh is the largest city in the County of Orange and the poorest. The city has one of the largest areas of historic houses in the region.

The city's population has continued to increase during the last twenty years by immigration and limited internal growth. The City of Newburgh has a population (2009) of over 28,000 persons. The City of Newburgh has the highest unemployment rates in the county.

The city consists of eight census tracts of 001, 002, 003.01, 003.02, 004, 005.01, 005.02, and 006. The subject property is in Census Tract 4, which is a lower income area of the City of Newburgh.

During the last 20 years, over 50% of the population growth within the City of Newburgh had incurred in Census Tract 4.00, which is also dominated by highest percentage of renters in the city. The city was considered an affordable community in the lower Hudson Region.

The major employers in Newburgh include St. Luke's Cornwall Hospital, 105th Airlift Wing- USAF Air National Guard, Stewart, C & S Wholesale Grocers Inc, Key Bank, Mid-Hudson Processing and Distribution USPS, Mount St. Mary College, AHRC-MR/DD Services and numerous large law firms.

Housing values in the City of Newburgh are 38% to 40% less than overall values in the County of Orange. Higher income families populate the area towards the east and many of these households have renovated their historic houses. In addition, this area has had some townhouse development in the 1980's and 1990's.

As 2025, renters in the city contain 61% of all households, the Town of Newburgh has only a 20% renter base.

The Town of Newburgh has a median household income of \$94,318 versus the City of Newburgh of only \$43,341.

Both the Town and City of Newburgh continue to have increases in population and households.

The poverty percentage of households in the City of Newburgh is 24%, but only 5.00% for the town. Education levels are significantly higher in the town with only 7% not having a high school diploma versus the city at 25%.

Demographic and Income Profile

Newburgh city, NY (3650034)
 Newburgh city, NY (3650034)
 Geography: Place



| Summary | Census 2020 | 2025 | 2030 |
|-------------------------------|-------------|--------|--------|
| Total Population | 28,856 | 28,760 | 29,005 |
| Total Households | 9,771 | 10,154 | 10,421 |
| Family Households | 6,351 | 6,386 | 6,497 |
| Average Household Size | 2.89 | 2.77 | 2.72 |
| Owner Occupied Housing Units | 2,952 | 3,074 | 3,240 |
| Renter Occupied Housing Units | 6,819 | 7,080 | 7,181 |
| Median Age | 31.7 | 32.9 | 33.7 |

| Trends 2025 - 2030 | Area | State | National |
|------------------------------|------|-------|----------|
| Population | 0.2% | -0.1% | 0.4% |
| Households | 0.5% | 0.2% | 0.6% |
| Family Population | 0.3% | 0.1% | 0.5% |
| Owner Occupied Housing Units | 1.1% | 0.3% | 0.0% |
| Median Household Income | 2.3% | 2.3% | 2.5% |

| Population by Age | Census 2020 | | 2025 | | 2030 | |
|-------------------|-------------|---------|--------|---------|--------|---------|
| | Number | Percent | Number | Percent | Number | Percent |
| 0-4 | 1,986 | 6.9% | 1,936 | 6.7% | 1,941 | 6.7% |
| 5-9 | 2,278 | 7.9% | 1,924 | 6.7% | 1,823 | 6.3% |
| 10-14 | 2,431 | 8.4% | 2,067 | 7.2% | 1,803 | 6.2% |
| 15-19 | 2,434 | 8.4% | 2,565 | 8.9% | 2,262 | 7.8% |
| 20-24 | 2,262 | 7.8% | 2,563 | 8.9% | 2,765 | 9.5% |
| 25-29 | 2,180 | 7.5% | 2,094 | 7.3% | 2,466 | 8.5% |
| 30-34 | 2,192 | 7.6% | 2,132 | 7.4% | 1,974 | 6.8% |
| 35-39 | 2,095 | 7.3% | 2,011 | 7.0% | 1,989 | 6.9% |
| 40-44 | 1,863 | 6.5% | 1,947 | 6.8% | 1,897 | 6.5% |
| 45-49 | 1,702 | 5.9% | 1,722 | 6.0% | 1,835 | 6.3% |
| 50-54 | 1,677 | 5.8% | 1,577 | 5.5% | 1,587 | 5.5% |
| 55-59 | 1,529 | 5.3% | 1,515 | 5.3% | 1,437 | 5.0% |
| 60-64 | 1,333 | 4.6% | 1,414 | 4.9% | 1,427 | 4.9% |
| 65-69 | 1,047 | 3.6% | 1,163 | 4.0% | 1,278 | 4.4% |
| 70-74 | 744 | 2.6% | 859 | 3.0% | 979 | 3.4% |
| 75-79 | 521 | 1.8% | 612 | 2.1% | 723 | 2.5% |
| 80-84 | 308 | 1.1% | 402 | 1.4% | 495 | 1.7% |
| Age 85+ | 274 | 0.9% | 257 | 0.9% | 324 | 1.1% |

Source: Esri forecasts for 2025 and 2030. U.S. Census Bureau 2020 decennial Census data

Valuation Analysis of the 581(a)

Year 2025

| Households by Income | 2025 | | 2030 | |
|--------------------------|----------|---------|----------|---------|
| | Number | Percent | Number | Percent |
| <\$10,000 | 905 | 8.9% | 817 | 7.8% |
| \$10,000-14,999 | 678 | 6.7% | 666 | 6.4% |
| \$15,000-19,999 | 376 | 3.7% | 305 | 2.9% |
| \$20,000-24,999 | 354 | 3.5% | 310 | 3.0% |
| \$25,000-29,999 | 486 | 4.8% | 423 | 4.1% |
| \$30,000-34,999 | 379 | 3.7% | 352 | 3.4% |
| \$35,000-39,999 | 274 | 2.7% | 270 | 2.6% |
| \$40,000-44,999 | 394 | 3.9% | 392 | 3.8% |
| \$45,000-49,999 | 424 | 4.2% | 413 | 4.0% |
| \$50,000-59,999 | 686 | 6.8% | 672 | 6.5% |
| \$60,000-74,999 | 834 | 8.2% | 881 | 8.4% |
| \$75,000-99,999 | 1,506 | 14.8% | 1,622 | 15.6% |
| \$100,000-124,999 | 867 | 8.5% | 948 | 9.1% |
| \$125,000-149,999 | 662 | 6.5% | 757 | 7.3% |
| \$150,000-199,999 | 950 | 9.4% | 1,116 | 10.7% |
| \$200,000-249,999 | 183 | 1.8% | 225 | 2.2% |
| \$250,000-299,999 | 119 | 1.2% | 156 | 1.5% |
| \$300,000-399,999 | 51 | 0.5% | 62 | 0.6% |
| \$400,000-499,999 | 19 | 0.2% | 27 | 0.3% |
| \$500,000+ | 7 | 0.1% | 7 | 0.1% |
| Median Household Income | \$61,831 | - | \$69,392 | - |
| Average Household Income | \$78,058 | - | \$84,316 | - |
| Per Capita Income | \$27,818 | - | \$30,550 | - |

| Race and Ethnicity | Census 2020 | | 2025 | | 2030 | |
|---------------------|-------------|---------|--------|---------|--------|---------|
| | Number | Percent | Number | Percent | Number | Percent |
| White Alone | 6,554 | 22.7% | 5,822 | 20.2% | 5,428 | 18.7% |
| Black Alone | 8,167 | 28.3% | 8,478 | 29.5% | 8,515 | 29.4% |
| American Indian | 656 | 2.3% | 686 | 2.4% | 700 | 2.4% |
| Asian Alone | 260 | 0.9% | 262 | 0.9% | 273 | 0.9% |
| Pacific Islander | 24 | 0.1% | 24 | 0.1% | 24 | 0.1% |
| Some Other Race | 9,737 | 33.7% | 10,058 | 35.0% | 10,560 | 36.4% |
| Two or More Races | 3,458 | 12.0% | 3,430 | 11.9% | 3,505 | 12.1% |
| Hispanic (Any Race) | 15,085 | 52.3% | 15,639 | 54.4% | 16,320 | 56.3% |

 **Source:** Esri forecasts for 2025 and 2030. U.S. Census Bureau 2020 decennial Census data

© 2026 Esri

Housing Profile

Newburgh city, NY (3650034)
 Newburgh city, NY (3650034)
 Geography: Place



Population

| | |
|-----------------------|--------|
| 2020 Total Population | 28,856 |
| 2025 Total Population | 28,760 |
| 2030 Total Population | 29,005 |
| 2025-2030 Annual Rate | 0.17% |

Households

| | |
|------------------------------|----------|
| 2025 Median Household Income | \$61,831 |
| 2030 Median Household Income | \$69,392 |
| 2025-2030 Annual Rate | 2.33% |

Housing Units by Occupancy Status and Tenure

| | Census 2020 | | 2025 | | 2030 | |
|---------------------|-------------|---------|--------|---------|--------|---------|
| | Number | Percent | Number | Percent | Number | Percent |
| Total Housing Units | 11,099 | 100.0% | 11,609 | 100.0% | 11,918 | 100.0% |
| Occupied | 9,771 | 88.0% | 10,154 | 87.5% | 10,421 | 87.4% |
| Owner | 2,952 | 30.2% | 3,074 | 30.3% | 3,240 | 31.1% |
| Renter | 6,819 | 69.8% | 7,080 | 69.7% | 7,181 | 68.9% |
| Vacant | 1,328 | 12.0% | 1,455 | 12.5% | 1,497 | 12.6% |

Owner Occupied Housing Units by Value

| | 2025 | | 2030 | |
|-------------------------|-----------|---------|-----------|---------|
| | Number | Percent | Number | Percent |
| Total | 3,068 | 100.0% | 3,234 | 100.0% |
| <\$50,000 | 90 | 2.9% | 115 | 3.6% |
| \$50,000-\$99,999 | 207 | 6.8% | 151 | 4.7% |
| \$100,000-\$149,999 | 361 | 11.8% | 220 | 6.8% |
| \$150,000-\$199,999 | 476 | 15.5% | 404 | 12.5% |
| \$200,000-\$249,999 | 427 | 13.9% | 444 | 13.7% |
| \$250,000-\$299,999 | 345 | 11.3% | 365 | 11.3% |
| \$300,000-\$399,999 | 480 | 15.7% | 512 | 15.8% |
| \$400,000-\$499,999 | 257 | 8.4% | 284 | 8.8% |
| \$500,000-\$749,999 | 223 | 7.3% | 405 | 12.5% |
| \$750,000-\$999,999 | 51 | 1.7% | 104 | 3.2% |
| \$1,000,000-\$1,499,999 | 121 | 3.9% | 190 | 5.9% |
| \$1,500,000-\$1,999,999 | 27 | 0.9% | 36 | 1.1% |
| \$2,000,000+ | 3 | 0.1% | 4 | 0.1% |
| Median Value | \$246,838 | | \$288,767 | |
| Average Value | \$329,155 | | \$393,596 | |

Data Note: Persons of Hispanic Origin may be of any race.

Source: Esri forecasts for 2025 and 2030. U.S. Census Bureau 2020 decennial Census data.

© 2026 Esri

Housing Profile | Newburgh city, NY (3650034) | Geography: Place

Census 2020 Housing Units

| | Number | Percent |
|---------------------|--------|---------|
| Total | 11,099 | 100.0% |
| Urban Housing Units | 11,099 | 100.0% |
| Rural Housing Units | 0 | 0.0% |

Census 2020 Owner Occupied Housing Units by Mortgage Status

| | Number | Percent |
|----------------------------|--------|---------|
| Total | 2,952 | 100.0% |
| Owned with a Mortgage/Loan | 2,138 | 72.4% |
| Owned Free and Clear | 814 | 27.6% |

Census 2020 Vacant Housing Units by Status

| | Number | Percent |
|--------------------------------------|--------|---------|
| Total | 1,328 | 100.0% |
| For Rent | 471 | 35.5% |
| Rented- Not Occupied | 42 | 3.2% |
| For Sale Only | 69 | 5.2% |
| Sold - Not Occupied | 42 | 3.2% |
| Seasonal/Recreational/Occasional Use | 52 | 3.9% |
| For Migrant Workers | 0 | 0.0% |
| Other Vacant | 652 | 49.1% |

Census 2020 Occupied Housing Units by Age of Householder and Home Ownership

| | Occupied Units | Owner Occupied Units | |
|-------|----------------|----------------------|---------------|
| | | Number | % of Occupied |
| Total | 9,771 | 2,952 | 30.2% |
| 15-24 | 391 | 29 | 1.0% |
| 25-34 | 1,799 | 264 | 8.9% |
| 35-44 | 2,131 | 523 | 17.7% |
| 45-54 | 1,871 | 651 | 22.1% |
| 55-59 | 870 | 328 | 11.1% |
| 60-64 | 837 | 338 | 11.4% |
| 65-74 | 1,147 | 494 | 16.7% |
| 75-84 | 529 | 224 | 7.6% |
| 85+ | 196 | 101 | 3.4% |

Data Note: Persons of Hispanic Origin may be of any race.

 **Source:** Esri forecasts for 2025 and 2030. U.S. Census Bureau 2020 decennial Census data.

© 2026 Esri

Housing Profile | Newburgh city, NY (3650034) | Geography: Place

Census 2020 Occupied Housing Units by Race/Ethnicity of Householder and Home Ownership

| | Occupied Units | Owner Occupied Units | |
|-------------------------------------|----------------|----------------------|---------------|
| | | Number | % of Occupied |
| Total | 9,771 | 2,952 | 30.2% |
| White Alone | 2,773 | 1,325 | 44.9% |
| Black/African American Alone | 3,003 | 628 | 21.3% |
| American Indian/Alaska Native Alone | 184 | 53 | 1.8% |
| Asian Alone | 102 | 59 | 2.0% |
| Pacific Islander Alone | 9 | 0 | 0.0% |
| Other Race Alone | 2,639 | 585 | 19.8% |
| Two or More Races | 1,061 | 302 | 10.2% |
| Hispanic Origin | 4,175 | 1,011 | 34.3% |

Census 2020 Occupied Housing Units by Size and Home Ownership

| | Occupied Units | Owner Occupied Units | |
|-----------|----------------|----------------------|---------------|
| | | Number | % of Occupied |
| Total | 9,771 | 2,952 | 30.2% |
| 1-Person | 2,769 | 759 | 25.7% |
| 2-Person | 2,320 | 831 | 28.1% |
| 3-Person | 1,610 | 452 | 15.3% |
| 4-Person | 1,438 | 414 | 14.0% |
| 5-Person | 897 | 239 | 8.1% |
| 6-Person | 447 | 155 | 5.3% |
| 7+ Person | 290 | 102 | 3.5% |

2025 Housing Affordability

| | |
|--------------------------------|-------|
| Housing Affordability Index | 79 |
| Percent of Income for Mortgage | 25.0% |

Data Note: Persons of Hispanic Origin may be of any race.

 Source: Esri forecasts for 2025 and 2030. U.S. Census Bureau 2020 decennial Census data.

© 2026 Esri

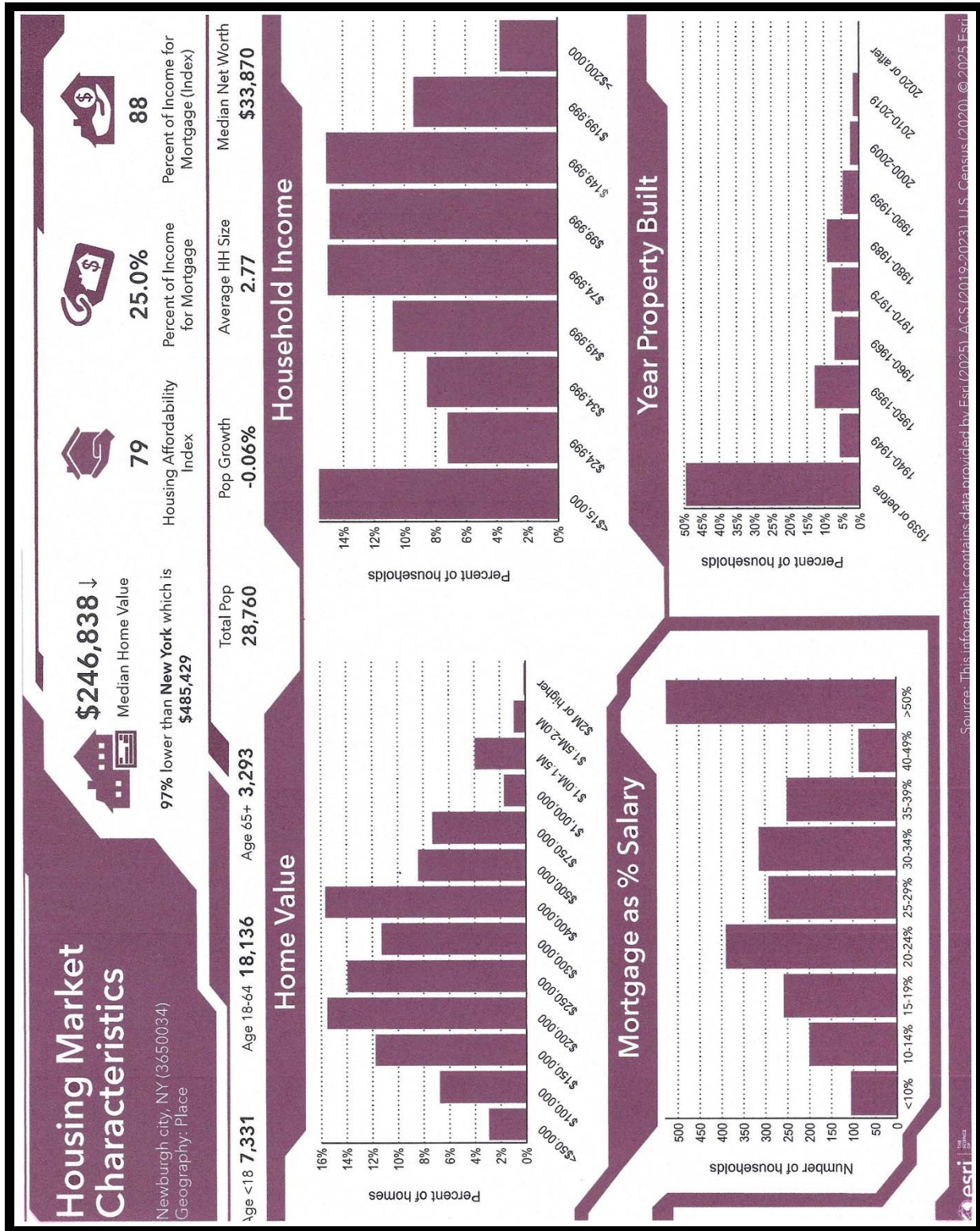

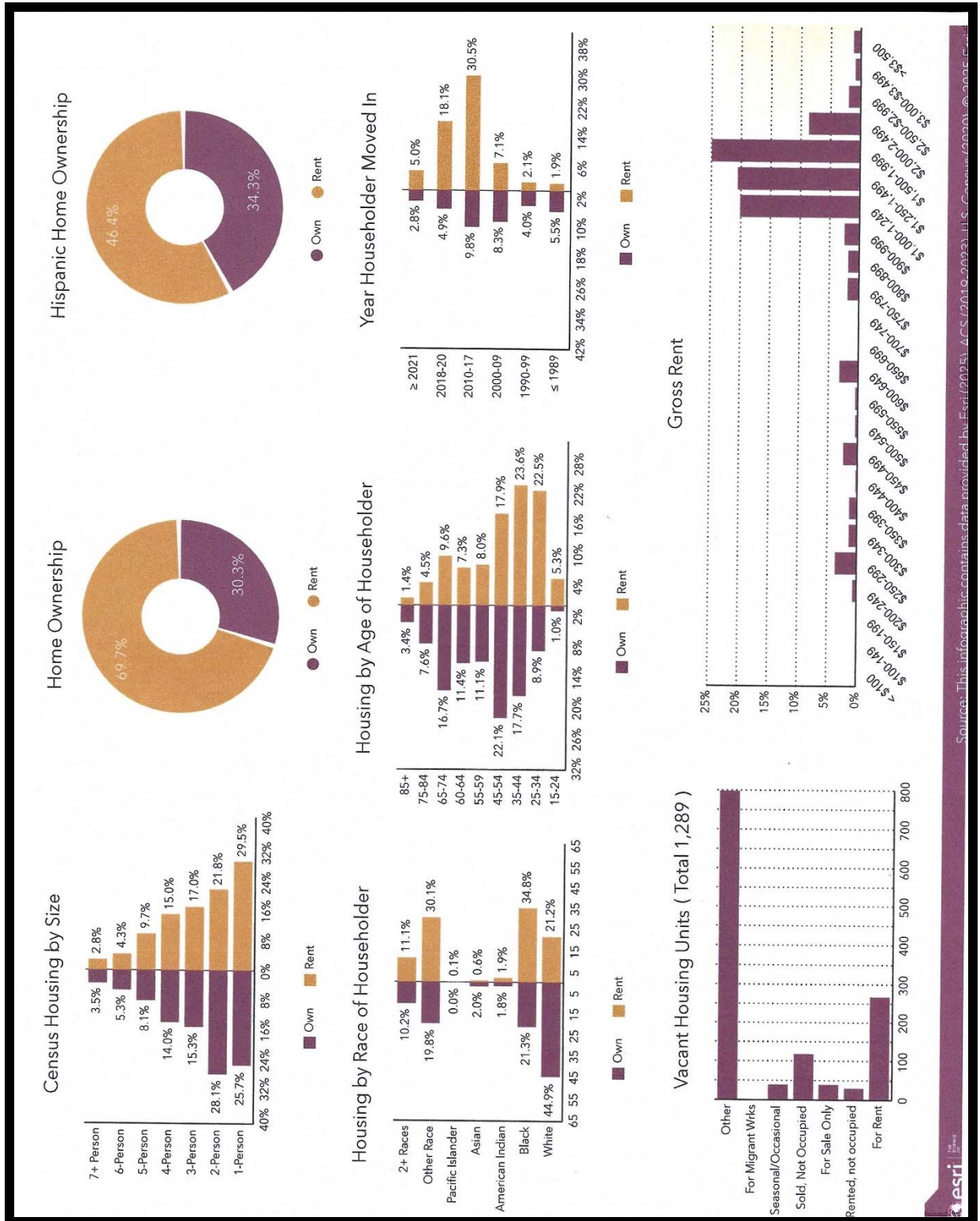



Source: This infographic contains data provided by Esri (2025). ACS (2019, 2023). U.S. Census Bureau. Esri

| Community Profile | | Newburgh city, NY (3650034) Geography: Place | |
|---|--|--|-----------|
| Per Capita Income | | Newburgh city... | |
| 2025 | | | \$27,818 |
| 2030 | | | \$30,550 |
| 2025 Households by Income | | | |
| Household Income Base | | | 10,154 |
| <\$10,000 | | | 8.9% |
| \$10,000-14,999 | | | 6.7% |
| \$15,000-19,999 | | | 3.7% |
| \$20,000-24,999 | | | 3.5% |
| \$25,000-29,999 | | | 4.8% |
| \$30,000-34,999 | | | 3.7% |
| \$35,000-39,999 | | | 2.7% |
| \$40,000-44,999 | | | 3.9% |
| \$45,000-49,999 | | | 4.2% |
| \$50,000-59,999 | | | 6.8% |
| \$60,000-74,999 | | | 8.2% |
| \$75,000-99,999 | | | 14.8% |
| \$100,000-124,999 | | | 8.5% |
| \$125,000-149,999 | | | 6.5% |
| \$150,000-199,999 | | | 9.4% |
| \$200,000-249,999 | | | 1.8% |
| \$250,000-299,999 | | | 1.2% |
| \$300,000-399,999 | | | 0.5% |
| \$400,000-499,999 | | | 0.2% |
| \$500,000+ | | | 0.1% |
| Average Household Income | | | \$78,058 |
| 2025 Affordability, Mortgage and Wealth | | | |
| Housing Affordability Index | | | 79 |
| Percent of Income for Mortgage | | | 25.0% |
| Wealth Index | | | 46 |
| Median Home Value | | | |
| 2025 | | | \$246,838 |
| 2030 | | | \$288,767 |
| <p><small>Source: Esri forecasts for 2025 and 2030. U.S. Census 2010 and 2020 Census data converted by Esri into 2020 geography. Consumer Spending data are derived from the 2022 and 2023 Consumer Expenditure Surveys, Bureau of Labor Statistics.</small></p> | | | |

| Community Profile | | Newburgh city, NY (3650034) Geography: Place | |
|------------------------------------|--|--|-------------------------|
| 2025 Home Value | | | Newburgh city... |
| Total Owner Occupied Housing Units | | | 3,068 |
| <\$50,000 | | | 2.9% |
| \$50,000 - \$99,999 | | | 6.8% |
| \$100,000 - \$149,999 | | | 11.8% |
| \$150,000 - \$199,999 | | | 15.5% |
| \$200,000 - \$249,999 | | | 13.9% |
| \$250,000 - \$299,999 | | | 11.3% |
| \$300,000 - \$399,999 | | | 15.7% |
| \$400,000 - \$499,999 | | | 8.4% |
| \$500,000 - \$749,999 | | | 7.3% |
| \$750,000 - \$999,999 | | | 1.7% |
| \$1,000,000 - \$1,499,999 | | | 3.9% |
| \$1,500,000 - \$1,999,999 | | | 0.9% |
| \$2,000,000 + | | | 0.1% |
| Average Home Value | | | \$329,155 |
| Housing Unit Summary | | | |
| 2010 Total Housing Units | | | 10,505 |
| Owner Occupied Housing Units | | | 31.8% |
| Renter Occupied Housing Units | | | 68.3% |
| Vacant Housing Units | | | 14.0% |
| 2020 Housing Units | | | 11,099 |
| Owner Occupied Housing Units | | | 30.2% |
| Renter Occupied Housing Units | | | 69.8% |
| Vacant Housing Units | | | 12.0% |
| 2025 Housing Units | | | 11,609 |
| Owner Occupied Housing Units | | | 30.3% |
| Renter Occupied Housing Units | | | 69.7% |
| Vacant Housing Units | | | 12.5% |
| 2030 Total Housing Units | | | 11,918 |
| Owner Occupied Housing Units | | | 31.1% |
| Renter Occupied Housing Units | | | 68.9% |
| Vacant Housing Units | | | 12.6% |

Source: Esri forecasts for 2025 and 2030. U.S. Census 2010 and 2020 Census data converted by Esri into 2020 geography. Consumer Spending data are derived from the 2022 and 2023 Consumer Expenditure Surveys, Bureau of Labor Statistics.

© 2026 Esri

| Community Profile | |  |
|--|--|---|
| Newburgh city, NY (3650034) | | |
| Newburgh city, NY (3650034) | | |
| Geography: Place | | |
| Population Summary | | Newburgh city... |
| 2010 Total Population | | 28,866 |
| 2020 Total Population | | 28,856 |
| 2020 Group Quarters | | 647 |
| 2025 Total Population | | 28,760 |
| 2025 Group Quarters | | 635 |
| 2030 Total Population | | 29,005 |
| 2025-2030 Annual Rate | | 0.17% |
| 2025 Total Daytime Population | | 27,479 |
| Workers | | 11,580 |
| Residents | | 15,899 |
| Household Summary | | |
| 2010 Total Households | | 9,030 |
| 2010 Average Household Size | | 3.09 |
| 2020 Total Households | | 9,771 |
| 2020 Average Household Size | | 2.89 |
| 2025 Total Households | | 10,154 |
| 2025 Average Household Size | | 2.77 |
| 2030 Total Households | | 10,421 |
| 2030 Average Household Size | | 2.72 |
| 2025-2030 Annual Rate | | 0.52% |
| 2025 Families | | 6,386 |
| 2025 Average Family Size | | 3.53 |
| 2030 Families | | 6,497 |
| 2030 Average Family Size | | 3.48 |
| 2025-2030 Growth Rate | | 0.3% |
| Median Household Income | | |
| 2025 | | \$61,831 |
| 2030 | | \$69,392 |
| <p> Source: Esri forecasts for 2025 and 2030. U.S. Census 2010 and 2020 Census data converted by Esri into 2020 geography. Consumer Spending data are derived from the 2022 and 2023 Consumer Expenditure Surveys, Bureau of Labor Statistics.</p> | | © 2026 Esri |

Census Tract Map

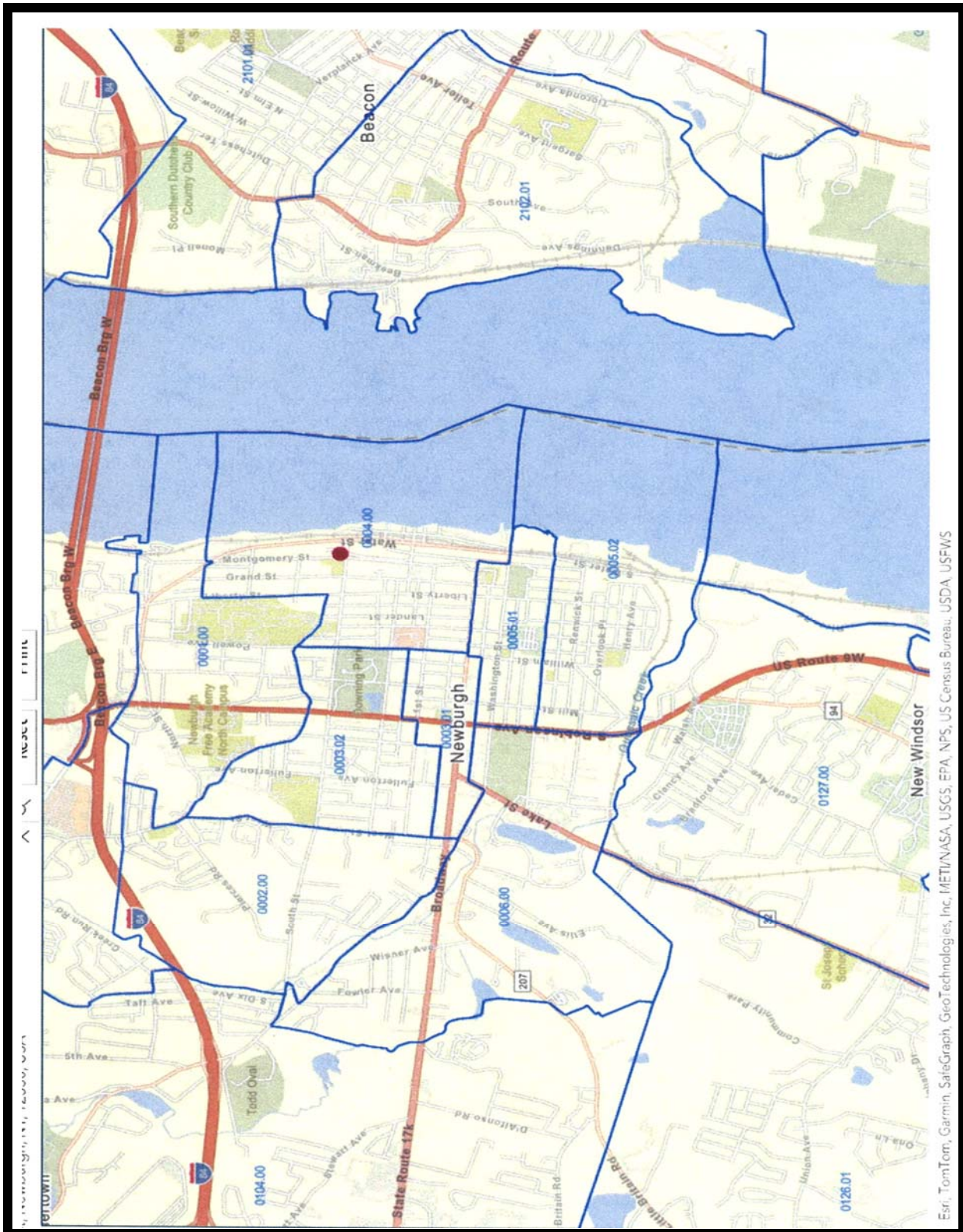

Esri, TomTom, Garmin, SafeGraph, GeoTechnologies, Inc., METI/NASA, USGS, EPA, NPS, US Census Bureau, USDA, USFWS

Valuation Analysis of the 581(a)

Year 2025

Census Tract Analysis – City of Newburgh

The following is summary analysis of the city by census track data. The subject is located in census track 4.00

| Census Tract | 1.00 | 2.00 | 3.01 | 3.02 |
|----------------------|-----------|-----------|-----------|----------|
| Median HH Income | \$42,127 | \$83,669 | \$100,700 | \$77,388 |
| Mean HH Income | \$95,869 | \$100,622 | \$117,118 | \$81,610 |
| % Families - Poverty | 14.8% | 14.7% | 0.0% | 21.9% |
| Population | 3,537 | 2,695 | 1,650 | 5,001 |
| Households | 1,277 | 953 | 526 | 1,469 |
| Median House Price | \$305,500 | \$255,400 | \$95,300 | 207,000 |
| Owner Occupied | 522 | 630 | 60 | 804 |
| Renter Occupied | 755 | 323 | 466 | 665 |

| Census Tract | 4.00 | 5.01 | 5.02 | 6.00. |
|----------------------|-----------|-----------|-----------|-----------|
| Median HH Income | \$36,091 | n/a | n/a | \$35,903 |
| Mean HH Income | \$62,068 | \$82,930 | \$83,390 | \$48,905 |
| % Families - Poverty | 39.0% | 33.7% | 7.8% | 21.2% |
| Population | 4,608 | 4,193 | 4,191 | 4,024 |
| Median House Price | \$228,000 | \$198,800 | \$339,900 | \$185,300 |
| Households | 1,803 | 1,474 | 1,474 | 1,740 |
| Owner Occupied | 596 | 418 | 1,313 | 249 |
| Renter Occupied | 1,297 | 1,056 | 740 | 1,391 |

Source: Census Data 2025

Police: The City of Newburgh Police Department is located at 55 Broadway, Newburgh New York. The department is comprised of eighty-three officers and 13 staff personnel. The City of Newburgh Police Department maintains several divisions including a crime unit, scuba/marine unit, motorcycle unit, bicycle unit, animal control, joint crimes task force to name a few.

Fire: The City of Newburgh Fire Department is located at 22 Grand Street, Newburgh, New York.

Post Office: The main Post Office for the City of Newburgh is located at 215-217 Liberty Street and the zip code is 12550. The area code is 845. The Town of Newburgh does not have a main Post Office they use the one located at 215-217 Liberty Street.

Medical: The Beacon/Newburgh area has two major medical centers. The closest hospital is Saint Lukes Hospital in the City of Newburgh, Saint Luke’s Cornwall-Hospital located at 70 Dubois Street in Newburgh, New York.

Major Roads: The New York State Thruway (I-87/90) has an interchange west of the city. The city has direct access to Interstate Highway I-84. Other major roads within the city are Routes 9W, 17K, and 32.

Transportation: Amtrak at Beacon provides rail transportation, across the Hudson River and there is a Metro North Station located to the southwest in Cornwall. The county maintains a bus system within the area, along Broadway, Liberty and Lake Streets. Stewart International Airport is located within a 10–minute drive of the site.

Valuation Analysis of the 581(a)

Year 2025

Utilities: The Central Hudson Gas and Electric Corporation supply electricity and natural gas to the area. The city is the supplier of water and sewer facilities. Electric, Gas, Sewer and Water are available to the sites.

Education: In 1963 the Newburgh Enlarged City School District was formed. It consisted of the City of Newburgh and most of the Town of New Windsor and several school districts in the Town of Newburgh. The Newburgh Enlarged City School District directs the public schools of the City of Newburgh, the Town of Newburgh, and the Town of New Windsor.

The District serves 12,000 students with 9 elementary schools, 3 Junior High's North, South and Heritage for grades 7-9 and 1 High School the New Free Academy with 2,685 students in grades 10-12.

Mount Saint Mary College is a 4-year liberal arts college with majors in Nursing and Education located at 330 Powell Avenue in Newburgh. SUNY Orange, a 2-year community college, operates a branch in Newburgh. A major expansion of the Newburgh campus is expected in the next few years.

Library: The Newburgh Enlarged City School District also operates the Newburgh Free Public Library located at 124 Grand Street, Newburgh.

Shopping: There are no major food stores within the City of Newburgh. The Rite Aid Drug chain has recently completed a store on Broadway. Most stores are convenience type establishments. However, there are numerous service type shops available within the city. The main local shopping is located along Route 300 (Union Avenue) near the intersection of Route

300 and I-84. There is a Walmart, Home Depot, The Newburgh Shopping Mall and other major retailers along this road.

There are some addition strip shopping center and food store along Route 52. The Newburgh Mall is conveniently located at 1401 Route 300 in Newburgh. The mall is a regional indoor shopping center with over 65 stores and services.

The area has several supermarkets, they include Shop Rite Supermarket, Price Chopper and Garcia's Supermarket, all located in Newburgh. There is a Hannaford Supermarket and Pharmacy in New Windsor at 2636 State Route 32. Additional pharmacies include Wal-Mart Pharmacy, Rite Aid Pharmacy, and Ace Drug Co. Inc.

Recreation: The City of Newburgh has numerous parks, memorials, and smaller open spaces they include Delano-Hitch Recreational Park, Downing Park, and the Audrey Carney Park.

Identification of the Property: The subject properties are located in the City of Newburgh, New York.

| Property | Tax Number | Owner | Book/ Page | Date of Sale |
|-----------------------|------------|------------------|------------|--------------|
| 140 Montgomery Street | 12-4-10 | City of Newburgh | 13076/1034 | Oct 2010 |
| 146 Montgomery Street | 12-4-2.1 | City of Newburgh | 13078/1034 | Oct 2020 |
| 137 Smith Street | 12-4-4.1 | City of Newburgh | 12814/1203 | Feb 2009 |
| | | | | |

Purpose of the Appraisal: The purpose of the appraisal is to estimate the market value of the fee simple interest of the building and related land parcel son March 7 2026, subject to zoning and site approval.

Property Rights Appraised: As of the appraisal date, March 26, 2026, the property is vacant land. The properties are being appraised as fee simple.

Use of the Appraisal: This appraisal is intended for the use by developer to calculate the tax under the 581-a

Other Untended users: The report may be NYS HFA

Personal Property: Included in the valuation is no personal property.

History of the Property; The property has not been sold for the last five years.

Hypothetical Condition: Yes

Extraordinary Assumptions Yes

Jurisdictional Exception: The valuation method as mandated by the RPTL 581-A is only the income approach. This has created a Jurisdictional Exception, as noted in this report.

Scope of the Assignment

The scope of an appraisal is defined as “the amount and type of information researched, and the analysis applied in an assignment” (USPAP). In accordance with our Letter of Engagement, this assignment involves:

- Research and analysis in preparation of a credible appraisal.
- Presentation of our research, analysis, and final opinions in a summary report format.

Additionally, this appraisal assignment was prepared to conform to the applicable requirements set forth under:

This appraisal is being prepared for refinancing apparition. The valuation method as mandated by RPTL 581-a is only the income approach. **This has created a *Jurisdictional Exception*.**

1. Obtained property data and related documents for the property.
2. Obtain financial data, real estate tax bills, and other needed data
3. Analyze revenues and expenses for trends and conditions
4. Estimated the value of the property by means of the income Approach -581(a)

Finally, I correlated and applied the resulting information in the valuation analysis.

Definition of Value and Interest Appraised

Market Value: Title XI of the Federal Financial Institutions Reform, Recovery, and Enforcement Act of 1989 (FIRREA) requires the Office of the Comptroller of the Currency (OCC) to adopt regulations regarding the performance and utilization of appraisals by national banks. Regulations under 12CFR, Part 34, Subpart C-Appraisers, 34.42 Definitions (f) specifies that all real estate appraisal reports be based upon the following definition of "market value":

The most probable price which a property should bring in a competitive and open market under all condition's requisite to a fair sale, the buyer and seller each acting prudently and knowledgeably, and assuming the price is not affected by undue stimulus. Implicit in this definition is the consummation of a sale as of a specified date and the passing of title from seller to buyer under conditions whereby:

- (1) Buyer and seller are typically motivated.
- (2) Both parties are well informed or well advised, and acting in what they consider their own best interests.
- (3) A reasonable time is allowed for exposure in the open market.
- (4) Payment is made in cash in U.S. dollars or in terms of financial arrangements comparable thereto; and
- (5) The price represents the normal consideration for the property sold unaffected by special or creative financing or sales concessions granted by anyone associated with the sale.

“As Is “ Value: The value of the property in its current condition and subject to the zoning in effect as of the current date of value.

Fee Simple Estate: Fee simple estate as defined in the *Dictionary of Real Estate Appraisal - Second Edition* and published by the American Institute of Real Estate Appraisers is as follows:

"Absolute ownership unencumbered by any other interest or estate; subject only to the limitations imposed by the government powers of taxation, eminent domain, police power, and escheat."

“As Is “ Value : The value of the property in its current condition and subject to the zoning in effect as of the current date of value.

Fee Simple Estate : Fee simple estate as defined in the *Dictionary of Real Estate Appraisal - Second Edition* and published by the American Institute of Real Estate Appraisers is as follows:

"Absolute ownership unencumbered by any other interest or estate; subject only to the limitations imposed by the government powers of taxation, eminent domain, police power, and escheat."

Leased Fee Estate: Leasehold Interest estate as defined in the *Dictionary of Real Estate Appraisal - Second Edition* and published by the American Institute of Real Estate Appraisers is as follows: "An ownership interest held by a landlord with the right of use and occupancy conveyed by lease to others; the rights of lesser or the Leasehold Interest owner and Leasehold Interest are specified by contract terms contained within the lease."

Leasehold Interest: Leasehold interest as defined in the “*The Appraisal of Real Estate -12th*” edition by the Appraisal Institute states as follows: The interest held by the lessee (*the tenant or renter*) through a lease transferring the rights of use and occupancy for a stated term under certain conditions.

Jurisdictional Exception Rule: If any part of USPAP is contrary to the law or public policy of any jurisdiction, only that part shall be void and no force or effect in that jurisdiction.

An appraiser using the **JURISDICTIONAL EXCEPTION RULE** must properly identify and comply with the law or regulation that precludes compliance with USPAP. In addition, the appraiser must disclose in the report the part of USPAP that is voided by that law and regulation and also cite in the report the specific law or regulation that precludes compliance with USPAP.

Extraordinary Assumption: An extraordinary assumption is defined as an assumption, directly related to a specific assignment, which, if found to be false, could alter the appraiser’s opinions or conclusions.

Hypothetical Condition: A hypothetical condition is defined as condition that which is contrary to what exists but is supposed for the purpose of the analysis.

Exposure Time: Under Paragraph 3 of the Definition of Market Value, the value opinion presumes that “A reasonable time is allowed for exposure in the open market”. Exposure time is defined as the length of time the property interest being appraised would have been offered on the market prior to the hypothetical consummation of a sale at the market value on the effective date of the appraisal. Exposure time is presumed to precede the effective date of the appraisal. The reasonable exposure period is a function of price, time and use. It is not an isolated opinion of time alone. Exposure time is different for various types of real estate and under various market conditions. As noted above, exposure time is always presumed to precede the effective date of appraisal. It is the length of time the property would have been offered prior to a hypothetical market value sale on the effective date of appraisal. It is a retrospective opinion based on an analysis of recent past events, assuming a competitive and open market. It assumes not only adequate, sufficient and reasonable time but adequate, sufficient and a reasonable marketing effort. Exposure time and conclusion of value are therefore interrelated.

Marketing Time: Marketing time is an opinion of the time that might be required to sell a real property interest at the appraised value. Marketing time is presumed to start on the effective date of the appraisal. (Marketing time is subsequent to the effective date of the appraisal and exposure time is presumed to precede the effective date of the appraisal). The opinion of marketing time uses some of the same data analyzed in the process of estimating reasonable exposure time and it is not intended to be a prediction of a date of sale.

*

Contingent and Limiting Conditions

This appraisal report has been made with the following general assumptions:

1. No opinion is intended to be expressed, and no responsibility is assumed for the legal description or for any matters which are legal in nature or require legal expertise or specialized knowledge beyond that of a real estate appraiser. Title to the Property is assumed to be good and marketable and the Property is assumed to be free and clear of all liens unless otherwise stated. No survey of the Property was undertaken.
2. The information contained in the Appraisal or upon which the Appraisal is based has been gathered from sources the Appraiser assumes to be reliable and accurate. Some of such information may have been provided by the owner of the Property. Neither the Appraiser shall be responsible for the accuracy or completeness of such information, including the correctness of opinions, dimensions, sketches, exhibits and factual matters.
3. The opinion of value is only as of the date stated in the Appraisal. Changes since that date in external and market factors or in the Property itself can significantly affect property value.
4. The Appraisal is to be used in whole and not in part. No part of the Appraisal shall be used in conjunction with any other appraisal. Publication of the Appraisal or any portion thereof without the prior written consent of Ferrigno Realty Advisors is prohibited. Except as may be otherwise stated in the letter of engagement, the Appraisal may not be used by any person other than the party to whom it is addressed or for purposes other than that for which it was prepared. No part of the Appraisal shall be conveyed to the public through advertising or used in any sales or promotional material without Richard Lampert Appraisal written consent..
5. Except as may be otherwise stated in the letter of engagement, the Appraiser shall not be required to give testimony in any court or administrative proceeding relating to the Property or the Appraisal.
6. The Appraisal assumes (a) responsible ownership and competent management of the Property; (b) there are no hidden or unapparent conditions of the Property, subsoil or structures that render the Property more or less valuable (no responsibility is assumed for such conditions or for arranging for engineering studies that may be required to discover them); (c) full compliance with all applicable federal, state and local zoning and environmental regulations and laws, unless noncompliance is stated, defined and analyzed in the Appraisal; and (d) all required licenses, certificates of occupancy and other governmental consents have been or can be obtained and renewed for any use on which the value opinion contained in the Appraisal is based.
7. The physical condition of the improvements analyzed within the Appraisal is based on visual inspection by the Appraiser or other person identified in the Appraisal. Ferrigno, LLC, Realty Advisors assumes no responsibility for the soundness of structural members or for the condition of mechanical equipment, plumbing or electrical components.
8. The projected potential gross income referred to in the Appraisal may be based on lease summaries provided by the owner or third parties. The Appraiser has not reviewed lease documents and assumes no responsibility for the authenticity or completeness of lease information provided by others. Richard Lampert Appraisal recommends that legal advice be obtained regarding the interpretation of lease provisions and the contractual rights of parties.

Contingent and Limiting Conditions

9. The projections of income and expenses are not predictions of the future. Rather, they are the Appraiser's opinion of current market thinking on future income and expenses. The Appraiser make no warranty or representation that these projections will materialize. The real estate market is constantly fluctuating and changing. It is not the Appraiser's task to predict or in any way warrant the conditions of a future real estate market; the Appraiser can only reflect what the investment community, as of the date of the Appraisal, envisages for the future in terms of rental rates, expenses, supply and demand.
10. Unless otherwise stated in the Appraisal, the existence of potentially hazardous or toxic materials which may have been used in the construction or maintenance of the improvements or may be located at or about the Property was not analyzed in arriving at the opinion of value. These materials (such as formaldehyde foam insulation, asbestos insulation and other potentially hazardous materials) may adversely affect the value of the Property. The Appraisers are not qualified to detect such substances. Richard Lampert Appraisal recommends that an environmental expert be employed to determine the impact of these matters on the opinion of value.
11. The author of this report is not qualified to comment on environmental issues that may affect the market value of the property appraised, including but not limited to pollution or contamination of land, buildings, water, groundwater or air. Unless expressly stated, the property is assumed to be free and clear of pollutants and contaminants, including but not limited to molds or mildews or the conditions that might give rise to either, and in compliance with all environmental condition, past, present, or future, that might affect the market value of the property appraised. If the party relying on this report requires information about environmental issues, then that party is cautioned to retain an expert qualified in such issues. We expressly deny any legal liability relating to the effect of environmental issues on the market value of the property being appraised
12. Unless otherwise stated in the Appraisal, compliance with the requirements of the Americans with Disabilities Act of 1990 (ADA) has not been analyzed in arriving at the opinion of value. Failure to comply with the requirements of the ADA may adversely affect the value of the property. Richard Lampert Appraisal recommends that an expert in this field be employed.
13. Additional work requested by the client beyond the scope of this assignment will be billed at our prevailing hourly rate. Preparation for court testimony, update valuations, additional research, depositions, travel or other proceedings will be billed at our prevailing hourly rate, plus reimbursement of expenses.
14. The reader acknowledges that Richard Lampert Appraisal been retained hereunder as an independent contractor to perform the services described herein and nothing in this agreement shall be deemed to create any other relationship between us. This assignment shall be deemed concluded and the services hereunder completed upon delivery to you of the appraisal report discussed herein.
15. This study has not been prepared for use in connection with litigation and this document is not suitable for use in a litigation action. Accordingly, no rights to expert testimony, pretrial or other conferences, deposition, or related services are included with this appraisal. Professional fees and expenses of Richard Lampert Appraisal either in accordance with the provisions of the engagement letter or arrangements at the time, as the case may be.

Report Support and Other

Richard J. Lampert

Summary of Professional Experience:

Actively engaged in real estate consulting, market analysis, investment research and appraisal since 1975. Market research assignments on senior citizens and multi-family projects in New York, Connecticut, New Jersey, Rhode Island and South Carolina.

Editor and Publisher of *The Waterbury Industrial and Office Report*, *The Greater Glens Falls & Saratoga Real Estate Report*, *Southeastern Connecticut Real Estate Report*, and *The Greater Danbury Office and Industrial Report*.

Extensive appraisal and consulting experience appraising all types of real property including office buildings, shopping centers, apartment buildings, and vacant land.

Richard J. Lampert - Real Estate Consultant and Appraiser, Pleasantville, NY

Cushman & Wakefield - Tri-State Financial Services Group, New York, NY

VMS Realty Partners, Vice President - Acquisitions & Technical Services, New York, NY

Landauer Associates, Assistant Vice President - Appraisal, New York, NY

Forest City Enterprises, Senior Analyst - Land Division, Cleveland, Ohio

NYS Urban Development Corporation, Real Estate Analyst, New York, NY

Education

Long Island University, Master of Science, *Taxation & Finance* - 1975

Saint Vincent College, Bachelor of Science, *Accounting* - 1973

Professional Affiliations

New York State Rural Advocates

New York - State Certified General Real Estate Appraiser NYS#: 46000006405

State of Connecticut - Certified General Real Estate Appraiser Conn # 0000354

Selected Clients

Clients include major commercial bank, local savings banks, Industrial corporations, law firms, accounting firms, developers, and real estate consulting firms.

Report Support and Other

Selected 581-A Assignments

| Property | Location | Units | Type |
|-----------------------|--------------|-------|--------|
| Rhinebeck | Rhinebeck | 80 | Family |
| Manor Lofts | Monticello | 75 | Family |
| Independence Square | Newburgh | 80 | Family |
| John Warren Apts | Mexico | 36 | Family |
| Greenwood Apartments | Mohawk | 8 | Family |
| Old Erie Place 1 | Jordan | 24 | Senior |
| Old Erie Place 2 | Jordan | 24 | Senior |
| Old Erie Place 3 | Jordan | 24 | Senior |
| Old Erie Place 4 | Jordan | 24 | Senior |
| Campus Apartments | Frankfort | 22 | Senior |
| Litchfield Apartments | Frankfort | 24 | Senior |
| Streamside Apartments | Frankfort | 20 | Senior |
| Paddocks Landing | Phoenix | 32 | Senior |
| Village Center | Phoenix | 25 | Family |
| Bradley Place | Phoenix | 24 | Family |
| Christopher Court | Phoenix | 40 | Family |
| Patrick Court | Phoenix | 24 | Senior |
| Austin Court | Phoenix | 24 | Family |
| Wolcott Meadows -1 | Wolcott | 40 | Family |
| Wolcott Meadows - 2 | Wolcott | 30 | Senior |
| Pendell Commons | Poughkeepsie | 72 | Mixed |
| Murphy Manor | Haverstraw | 28 | Family |
| Kensico Terrace | White Plains | 42 | Family |
| Poughkeepsie Commons | Poughkeepsie | 72 | Mixed |
| Ulster Gardens | Ulster | 164 | Mixed |
| Pawling Seniors | Pawling | 74 | Senior |
| Union School | Syracuse | 40 | Senior |
| Independence Square | Newburgh | 72 | Mixed |
| Minetto Seniors | Minetto | 39 | Senior |
| Woodrow Wilson | Amsterdam | 100 | Family |

Report Support and Other

The following documents are included in the addenda.

| Document | Description |
|-----------------------|--|
| Assignment Letter | Oral over telephone |
| Appraisal License | Page 41 |
| Property Card 1 | Page 42 |
| Property Card 2 | Page 44 |
| Property Card 3 | Page 46 |
| ESRI Demographic Data | In files additional data |
| Additional Data | Additional data and materials are maintained in the subject's and regional files in my office. |

Support Data and Documents

New York State Appraisal License

UNIQUE ID NUMBER
46000006405

State of New York
Department of State
DIVISION OF LICENSING SERVICES

PURSUANT TO THE PROVISIONS OF ARTICLE 6E OF THE
EXECUTIVE LAW AS IT RELATES TO R. E. APPRAISERS.

LAMPERT RICHARD J
C/O RICHARD J LAMPERT REAL EST
231B HERITAGE HILLS DR
SOMERS, NY 10589

HAS BEEN DULY CERTIFIED TO TRANSACT BUSINESS AS A
R. E. GENERAL APPRAISER

FOR OFFICE USE ONLY
Control No. 1581121

EFFECTIVE DATE
MO. | DAY | YR.
01 | 07 | 26

EXPIRATION DATE
MO. | DAY | YR.
01 | 06 | 28



In Witness Whereof, The Department of State has caused
its official seal to be hereunto affixed.

WALTER T. MOSLEY
SECRETARY OF STATE

DCS-1098 (Rev. 3-07)

Support Data and Documents

Tax Parcel 1

| | | | |
|---|--------------------------------------|---|--|
|  | | Property Description Report For: 140 Montgomery St, Municipality of City of Newburgh | |
|  | | Status: | Active |
| | | Roll Section: | Wholly Exem |
| | | Swis: | 331100 |
| | | Tax Map ID #: | 12-4-10 |
| | | Property Class: | 311 - Res vac land |
| | | Site: | RES 1 |
| | | In Ag. District: | No (1.0000) |
| | | Site Property Class: | 311 - Res vac land |
| | | Zoning Code: | WG |
| | | Neighborhood Code: | 00004 - N East |
| | | School District: | Newburgh |
| | | Total Assessment: | 2025 - \$132,000 2024 - \$120,000 |
| Total Acreage/Size: | 146 x 173 | Property Desc: | 140-144 Montgomery St fka 62-74 South |
| Land Assessment: | 2025 - \$132,000 2024 - \$120,000 | Deed Page: | 1034 |
| Full Market Value: | 2025 - \$132,000 2024 - \$120,000 | Grid North: | 974296 |
| Equalization Rate: | ---- | | |
| Deed Book: | 13076 | | |
| Grid East: | 627049 | | |
| Area | | | |
| Living Area: | 0 sq. ft. | First Story Area: | 0 sq. ft. |
| Second Story Area: | 0 sq. ft. | Half Story Area: | 0 sq. ft. |
| Additional Story Area: | 0 sq. ft. | 3/4 Story Area: | 0 sq. ft. |
| Finished Basement: | 0 sq. ft. | Number of Stories: | 0 |
| Finished Rec Room: | 0 sq. ft. | Finished Area Over Garage: | 0 sq. ft. |
| Structure | | | |
| Building Style: | 0 | Bathrooms (Full - Half): | 0 - 0 |
| Bedrooms: | 0 | Kitchens: | 0 |
| Fireplaces: | 0 | Basement Type: | 0 |
| Porch Type: | 0 | Porch Area: | 0.00 |
| Basement Garage Cap: | 0 | Attached Garage Cap: | 0.00 sq. ft. |
| Overall Condition: | 0 | Overall Grade: | |
| Year Built: | | Eff Year Built: | |
| Owners | | | |
| City of Newburgh 83 Broadway Newburgh NY 12550 | | | |

Support Data and Documents

3/28/26, 7:51 PM

Printer Friendly Report - Image Mate Online

Sales

| Sale Date | Price | Property Class | Sale Type | Prior Owner | Value Usable | Arms Length | Add. Parcels | Deed Book and Page |
|------------|-------|--------------------|-----------|----------------|--------------|-------------|--------------|--------------------|
| 10/18/2010 | \$1 | 350 - Urban renewl | Land Only | Newburgh Urban | No | No | Yes | 13076/1034 |

Utilities

| | | | |
|--------------------|-------------|----------------------|-------------|
| Sewer Type: | Comm/public | Water Supply: | Comm/public |
| Utilities: | Gas & elec | Heat Type: | 0 |
| Fuel Type: | 0 | Central Air: | No |

Improvements

| Structure | Size | Grade | Condition | Year |
|-----------|------|-------|-----------|------|
|-----------|------|-------|-----------|------|

Special Districts for 2025

No information available for the 2025 roll year.

Special Districts for 2024

No information available for the 2024 roll year.

Exemptions

| Year | Description | Amount | Exempt % | Start Yr | End Yr | V Flag | H Code | Own % |
|------|-------------|-----------|----------|----------|--------|--------|--------|-------|
| 2025 | CITY OWNED | \$132,000 | 0 | 2011 | | | | 0 |
| 2024 | CITY OWNED | \$120,000 | 0 | 2011 | | | | 0 |



Taxes

| Year | Description | Amount |
|------|-------------|--------|
|------|-------------|--------|

*** Taxes reflect exemptions, but may not include recent changes in assessment.**

Support Data and Documents

Tax Parcel 2

| | | | |
|---|--|---|--|
|  | | Property Description Report For: 146 Montgomery St, Municipality of City of Newburgh | |
|  | | Status: Active Roll Section: Wholly Exem Swis: 331100 Tax Map ID #: 12-4-2.1 Property Class: 311 - Res vac land Site: RES 1 In Ag. District: No (1.0000) Site Property Class: 311 - Res vac land Zoning Code: WG Neighborhood Code: 00004 - N East School District: Newburg Total Assessment: 2025 - \$123,200 2024 - \$112,000 | |
| Total Acreage/Size: 0.41 Land Assessment: 2025 - \$123,200 2024 - \$112,000 Full Market Value: 2025 - \$123,200 2024 - \$112,000 Equalization Rate: ---- | | Property Desc: fka 146-152 Montgomery 159-165 Smith St Deed Page: 1034 Grid North: 974481 | |
| Deed Book: 13076 Grid East: 627049 | | | |
| Area | | | |
| Living Area: 0 sq. ft. Second Story Area: 0 sq. ft. Additional Story Area: 0 sq. ft. Finished Basement: 0 sq. ft. Finished Rec Room: 0 sq. ft. | | First Story Area: 0 sq. ft. Half Story Area: 0 sq. ft. 3/4 Story Area: 0 sq. ft. Number of Stories: 0 Finished Area Over Garage: 0 sq. ft. | |
| Structure | | | |
| Building Style: 0 Bedrooms: 0 Fireplaces: 0 Porch Type: 0 Basement Garage Cap: 0 Overall Condition: 0 Year Built: | | Bathrooms (Full - Half): 0 - 0 Kitchens: 0 Basement Type: 0 Porch Area: 0.00 Attached Garage Cap: 0.00 sq. ft. Overall Grade: Eff Year Built: | |
| Owners City of Newburgh 83 Broadway Newburgh NY 12550 | | | |

Support Data and Documents

3/28/26, 7:40 PM

Printer Friendly Report - Image Mate Online

Sales

| Sale Date | Price | Property Class | Sale Type | Prior Owner | Value Usable | Arms Length | Add. Parcels | Deed Book and Page |
|------------|-------|--------------------|-----------|----------------|--------------|-------------|--------------|--------------------|
| 10/18/2010 | \$1 | 350 - Urban renewl | Land Only | Newburgh Urban | No | No | Yes | 13076/1034 |

Utilities

| | | | |
|--------------------|-------------|----------------------|-------------|
| Sewer Type: | Comm/public | Water Supply: | Comm/public |
| Utilities: | Gas & elec | Heat Type: | 0 |
| Fuel Type: | 0 | Central Air: | No |

Improvements

| Structure | Size | Grade | Condition | Year |
|-----------|------|-------|-----------|------|
|-----------|------|-------|-----------|------|

Special Districts for 2025

No information available for the 2025 roll year.

Special Districts for 2024

No information available for the 2024 roll year.

Exemptions

| Year | Description | Amount | Exempt % | Start Yr | End Yr | V Flag | H Code | Own % |
|------|-------------|-----------|----------|----------|--------|--------|--------|-------|
| 2025 | CITY OWNED | \$123,200 | 0 | 2011 | | | | 0 |
| 2024 | CITY OWNED | \$112,000 | 0 | 2011 | | | | 0 |

Taxes

| Year | Description | Amount |
|------|-------------|--------|
|------|-------------|--------|

*** Taxes reflect exemptions, but may not include recent changes in assessment.**

Support Data and Documents

Tax Parcel 3



Property Description Report For: 137 Smith St, Municipality of City of Newburgh



Total Acreage/Size: 218 x 66
Land Assessment: 2025 - \$67,800
 2024 - \$61,600
Full Market Value: 2025 - \$67,800
 2024 - \$61,600
Equalization Rate: ---
Deed Book: 12814
Grid East: 627092

Status: Active
Roll Section: Wholly Exem
Swis: 331100
Tax Map ID #: 12-4-4.1
Property Class: 311 - Res vac land
Site: RES 1
In Ag. District: No (1.0000)
Site Property Class: 311 - Res vac land
Zoning Code: WG
Neighborhood Code: 00004 - N East
School District: Newburg
Total Assessment: 2025 - \$67,800
 2024 - \$61,600

Property Desc: fka 137-157 Smith
Deed Page: 1203
Grid North: 974578

Area

| | |
|---|---|
| Living Area: 0 sq. ft. | First Story Area: 0 sq. ft. |
| Second Story Area: 0 sq. ft. | Half Story Area: 0 sq. ft. |
| Additional Story Area: 0 sq. ft. | 3/4 Story Area: 0 sq. ft. |
| Finished Basement: 0 sq. ft. | Number of Stories: 0 |
| Finished Rec Room: 0 sq. ft. | Finished Area Over Garage: 0 sq. ft. |

Structure

| | |
|-------------------------------|--|
| Building Style: 0 | Bathrooms (Full - Half): 0 - 0 |
| Bedrooms: 0 | Kitchens: 0 |
| Fireplaces: 0 | Basement Type: 0 |
| Porch Type: 0 | Porch Area: 0.00 |
| Basement Garage Cap: 0 | Attached Garage Cap: 0.00 sq. ft. |
| Overall Condition: 0 | Overall Grade: |
| Year Built: | Eff Year Built: |

Owners

City of Newburgh
 83 Broadway
 Newburgh NY 12550

Support Data and Documents

| 3/28/26, 7:55 PM | | Printer Friendly Report - Image Mate Online | | | | | | |
|--|-------------|---|-----------|----------------------|--------------|-------------|--------------|--------------------|
| Sales | | | | | | | | |
| Sale Date | Price | Property Class | Sale Type | Prior Owner | Value Usable | Arms Length | Add. Parcels | Deed Book and Page |
| 2/12/2009 | \$1 | 350 - Urban renewl | Land Only | City of Newburgh | No | No | No | 12814/1203 |
| Utilities | | | | | | | | |
| Sewer Type: | | Comm/public | | Water Supply: | | Comm/public | | |
| Utilities: | | Gas & elec | | Heat Type: | | 0 | | |
| Fuel Type: | | 0 | | Central Air: | | No | | |
| Improvements | | | | | | | | |
| Structure | Size | Grade | Condition | Year | | | | |
| Special Districts for 2025 | | | | | | | | |
| <i>No information available for the 2025 roll year.</i> | | | | | | | | |
| Special Districts for 2024 | | | | | | | | |
| <i>No information available for the 2024 roll year.</i> | | | | | | | | |
| Exemptions | | | | | | | | |
| Year | Description | Amount | Exempt % | Start Yr | End Yr | V Flag | H Code | Own % |
| 2025 | CITY OWNED | \$67,800 | 0 | 2009 | | | | 0 |
| 2024 | CITY OWNED | \$61,600 | 0 | 2009 | | | | 0 |
| Taxes | | | | | | | | |
| Year | Description | Amount | | | | | | |
| 2009 | County | \$713.52 | | | | | | |
| * Taxes reflect exemptions, but may not include recent changes in assessment. | | | | | | | | |

Support Data and Documents



CITY OF NEWBURGH

OFFICE OF THE CITY ASSESSOR

83 Broadway, Newburgh, New York 12550
(845) 569-7333 • www.cityofnewburgh-ny.gov

Jason Morris, PE
Interim City Manager

Renée Ozomek, IAO
City Assessor

April 16, 2026

Re: Project Name: "The Green"
RPT §581-a Analysis

For "The Green" project proposal, the developer's appraiser determined the value for this project to be \$8,750,000 based upon a "loaded capitalization rate" (a/k/a "loaded cap rate") of 12.5189%.

The project will be subject to, and eligible for, a RPTL §581-a valuation analysis. This type of valuation also utilizes capitalization rates (a/k/a "cap rates"). Cap rates are calculated as net operating income divided by market value. To estimate a project's market value, take a project's net operating income and divide it by the cap rate.

Cap rates for market rate, multi-family housing in Newburgh for 2026 range from 6.5% to 8.5%. Cap rates for §581-a eligible housing in Newburgh range from approximately 7.50% to 8.50%.

A loaded cap rate is the cap rate plus the mill rate. The mill rate is another term for the tax rate in a jurisdiction. The most current mill rate for Newburgh is 3.0189%. Using a loaded cap rate analysis can be more accurate in providing a property valuation because it considers a known tax rate in a particular taxing jurisdiction.

Cap rates (and loaded cap rates) for projects of the type proposed may be adjusted higher based on risk and location. The appraiser uses a cap rate of 9.5% / loaded cap rate of 12.1589%. Given the low vacancy rate of rental apartments in the City of Newburgh and demand for rental apartment units, no increased risk appears warranted for a project of this type. The developer's appraiser also noted an increasing demand for low-income and affordable housing. Therefore, loaded cap rate ranges between 10.5189% and 12.5189% are reasonable for valuation purposes.

The calculations provided show valuations at loaded cap rates between 10.5189% and 12.5189%, at 0.25% increments. Also provided are the projected tax amounts that correspond to each valuation based on current-year tax rates and an assumption for three percent (3%) annual increases.



Renée Ozomek, IAO
City Assessor

| Cap Rate Computation and Project Valuation - The Green | | | | | | | | | | | | | | | | | | | | |
|--|---------------------------------------|---------------------------------------|------------------------|-----------------------|------------------------|-----------------------|------------------------|-----------------------|------------------------|-----------------------|------------------------|-----------------------|------------------------|-----------------------|------------------------|-----------------------|------------------------|-----------------------|------------------------|-----------------------|
| | | Tax Projections at Various Cap Rates* | | | | | | | | | | | | | | | | | | |
| Year | Developer Proposed PILOT Payments* | Cap Rate Property Valuation | 9.50% | | 9.25% | | 9.00% | | 8.75% | | 8.50% | | 8.25% | | 8.00% | | 7.75% | | 7.50% | |
| | | | \$8,750,000 | Difference (9.50%) | \$8,930,000 | Difference (9.25%) | \$9,120,000 | Difference (9.00%) | \$9,300,000 | Difference (8.75%) | \$9,515,000 | Difference (8.50%) | \$9,725,000 | Difference (8.25%) | \$9,950,000 | Difference (8.00%) | \$10,175,000 | Difference (7.75%) | \$10,420,000 | Difference (7.50%) |
| Year 1 | \$175,700.00 | | \$264,141.13 | \$88,441.13 | \$269,585.09 | \$93,885.09 | \$275,320.94 | \$99,620.94 | \$280,754.91 | \$105,054.91 | \$287,245.48 | \$111,545.48 | \$293,585.11 | \$117,885.11 | \$300,377.57 | \$124,677.57 | \$307,170.02 | \$131,470.02 | \$314,566.25 | \$138,866.25 |
| Year 2 | \$180,971.00 | | \$272,065.36 | \$91,094.36 | \$277,672.64 | \$96,701.64 | \$283,580.57 | \$102,609.57 | \$289,177.56 | \$108,206.56 | \$295,862.84 | \$114,891.84 | \$302,392.66 | \$121,421.66 | \$309,388.90 | \$128,417.90 | \$316,385.12 | \$135,414.12 | \$324,003.24 | \$143,032.24 |
| Year 3 | \$186,400.13 | | \$280,227.32 | \$93,827.19 | \$286,002.82 | \$99,602.69 | \$292,087.99 | \$105,687.86 | \$297,852.88 | \$111,452.75 | \$304,738.73 | \$118,338.60 | \$311,464.44 | \$125,064.31 | \$318,670.56 | \$132,270.43 | \$325,876.67 | \$139,476.54 | \$333,723.33 | \$147,323.20 |
| Year 4 | \$191,992.13 | | \$288,634.14 | \$96,642.01 | \$294,582.91 | \$102,590.78 | \$300,850.62 | \$108,858.49 | \$306,788.47 | \$114,796.34 | \$313,880.89 | \$121,888.76 | \$320,808.38 | \$128,816.25 | \$328,230.68 | \$136,238.55 | \$335,652.97 | \$143,660.84 | \$343,735.03 | \$151,742.90 |
| Year 5 | \$197,751.90 | | \$297,293.17 | \$99,541.27 | \$303,420.39 | \$105,668.49 | \$309,876.14 | \$112,124.24 | \$315,992.12 | \$121,240.22 | \$323,297.32 | \$125,545.42 | \$330,432.63 | \$132,660.73 | \$338,077.60 | \$140,325.70 | \$345,722.56 | \$147,970.66 | \$354,047.09 | \$156,295.19 |
| Year 6 | \$203,684.45 | | \$306,211.96 | \$102,527.51 | \$312,523.01 | \$108,838.56 | \$319,172.43 | \$115,487.98 | \$325,471.89 | \$121,787.44 | \$332,996.24 | \$129,311.79 | \$340,345.61 | \$136,661.16 | \$348,219.93 | \$144,535.48 | \$356,094.24 | \$152,409.79 | \$364,668.50 | \$160,984.05 |
| Year 7 | \$209,794.99 | | \$315,398.32 | \$105,603.33 | \$321,898.70 | \$112,103.71 | \$328,747.60 | \$118,952.61 | \$335,236.05 | \$125,441.06 | \$342,986.13 | \$133,191.14 | \$350,555.97 | \$140,760.98 | \$358,666.53 | \$148,871.54 | \$366,777.07 | \$156,982.08 | \$375,608.55 | \$165,813.56 |
| Year 8 | \$216,088.84 | | \$324,860.27 | \$108,771.43 | \$331,555.66 | \$115,466.82 | \$338,610.03 | \$122,521.19 | \$345,293.13 | \$129,204.29 | \$353,275.71 | \$137,186.87 | \$361,072.65 | \$144,983.81 | \$369,426.52 | \$153,337.68 | \$377,780.38 | \$161,691.54 | \$386,876.81 | \$170,787.97 |
| Year 9 | \$222,571.50 | | \$334,606.08 | \$112,034.58 | \$341,502.33 | \$118,930.83 | \$348,768.33 | \$126,196.83 | \$355,651.92 | \$133,080.42 | \$363,873.98 | \$141,302.48 | \$371,904.83 | \$149,333.33 | \$380,509.32 | \$157,937.82 | \$389,113.79 | \$166,542.29 | \$398,483.11 | \$175,911.61 |
| Year 10 | \$229,248.65 | | \$344,644.26 | \$115,395.61 | \$351,747.40 | \$122,498.75 | \$359,231.38 | \$129,982.73 | \$366,321.48 | \$137,072.83 | \$374,790.20 | \$145,541.55 | \$383,061.98 | \$153,813.33 | \$391,924.60 | \$162,675.95 | \$400,787.20 | \$171,538.55 | \$410,437.61 | \$181,188.96 |
| Year 11 | \$236,126.11 | | \$354,983.59 | \$118,857.48 | \$362,299.82 | \$126,173.71 | \$370,008.32 | \$133,882.21 | \$377,311.12 | \$141,185.01 | \$386,033.91 | \$149,907.80 | \$394,553.84 | \$158,427.73 | \$403,682.34 | \$167,556.23 | \$412,810.82 | \$176,684.71 | \$422,750.74 | \$186,624.63 |
| Year 12 | \$243,209.89 | | \$365,633.10 | \$122,423.21 | \$373,168.81 | \$129,958.92 | \$381,108.57 | \$137,898.68 | \$388,630.46 | \$145,420.57 | \$397,614.92 | \$154,405.03 | \$406,390.45 | \$163,180.56 | \$415,792.81 | \$172,582.92 | \$425,195.15 | \$181,985.26 | \$435,433.26 | \$192,223.37 |
| Year 13 | \$250,506.19 | | \$376,602.09 | \$126,095.90 | \$384,363.88 | \$133,857.69 | \$392,541.83 | \$142,035.64 | \$400,289.37 | \$149,783.18 | \$409,543.37 | \$159,037.18 | \$418,582.17 | \$168,075.98 | \$428,266.59 | \$177,760.40 | \$437,951.00 | \$187,444.81 | \$448,496.26 | \$197,990.07 |
| Year 14 | \$258,021.37 | | \$387,900.15 | \$129,878.78 | \$395,894.79 | \$137,873.42 | \$404,318.08 | \$146,296.71 | \$412,298.05 | \$154,276.68 | \$421,829.67 | \$163,808.30 | \$431,139.63 | \$173,118.26 | \$441,114.59 | \$183,093.22 | \$451,089.53 | \$193,068.16 | \$461,951.14 | \$203,929.77 |
| Year 15 | \$265,762.01 | | \$399,537.16 | \$133,775.15 | \$407,771.64 | \$142,009.63 | \$416,447.62 | \$150,685.61 | \$424,666.99 | \$158,904.98 | \$434,484.56 | \$168,722.55 | \$444,073.82 | \$178,311.81 | \$454,348.03 | \$188,586.02 | \$464,622.22 | \$198,860.21 | \$475,809.68 | \$210,047.67 |
| Year 16 | \$273,734.88 | | \$411,523.27 | \$137,788.39 | \$420,004.79 | \$146,269.91 | \$428,941.05 | \$155,206.17 | \$437,407.00 | \$163,672.12 | \$447,519.10 | \$173,784.22 | \$457,396.04 | \$183,661.16 | \$467,978.47 | \$194,243.59 | \$478,560.88 | \$204,826.00 | \$490,083.97 | \$216,349.09 |
| Year 17 | \$281,946.92 | | \$423,868.97 | \$141,922.05 | \$432,604.93 | \$150,658.01 | \$441,809.29 | \$159,862.37 | \$450,529.21 | \$168,582.29 | \$460,944.67 | \$178,997.75 | \$471,117.92 | \$189,171.00 | \$482,017.82 | \$200,070.90 | \$492,917.71 | \$210,970.79 | \$504,786.49 | \$222,839.57 |
| Year 18 | \$290,405.33 | | \$436,585.04 | \$146,179.71 | \$445,583.08 | \$155,177.75 | \$455,063.56 | \$164,658.23 | \$464,045.09 | \$173,639.76 | \$474,773.01 | \$184,367.68 | \$485,251.45 | \$194,846.12 | \$496,478.36 | \$206,073.03 | \$507,705.24 | \$217,299.91 | \$519,930.08 | \$229,524.75 |
| Year 19 | \$299,117.49 | | \$449,682.59 | \$150,565.10 | \$458,950.57 | \$159,833.08 | \$468,715.47 | \$169,597.98 | \$477,966.44 | \$178,848.95 | \$489,016.20 | \$189,898.71 | \$499,809.00 | \$200,691.51 | \$511,372.71 | \$212,255.22 | \$522,936.40 | \$223,818.91 | \$535,527.98 | \$236,410.49 |
| Year 20 | \$308,091.01 | | \$463,173.07 | \$155,082.06 | \$472,719.09 | \$164,628.08 | \$482,776.93 | \$174,685.92 | \$492,305.43 | \$184,214.42 | \$503,686.69 | \$195,595.68 | \$514,803.27 | \$206,712.26 | \$526,713.89 | \$218,622.88 | \$538,624.49 | \$230,533.48 | \$551,593.82 | \$243,502.81 |
| Year 21 | \$317,333.74 | | \$477,068.26 | \$159,734.52 | \$486,900.66 | \$169,566.92 | \$497,260.24 | \$179,926.50 | \$507,074.60 | \$189,740.86 | \$518,797.29 | \$201,463.55 | \$530,247.37 | \$212,913.63 | \$542,515.30 | \$225,181.56 | \$554,783.22 | \$237,449.48 | \$568,141.64 | \$250,807.90 |
| Year 22 | \$326,853.76 | | \$491,380.31 | \$164,526.55 | \$501,507.68 | \$174,653.92 | \$512,178.05 | \$185,324.29 | \$522,286.84 | \$195,433.08 | \$534,361.21 | \$207,507.45 | \$546,154.79 | \$219,301.03 | \$558,790.76 | \$231,937.00 | \$571,426.72 | \$244,572.96 | \$585,185.89 | \$258,332.13 |
| Year 23 | \$336,659.37 | | \$506,121.72 | \$169,462.35 | \$516,552.91 | \$179,893.54 | \$527,543.39 | \$190,884.02 | \$537,955.44 | \$201,296.07 | \$550,392.04 | \$213,732.67 | \$562,539.43 | \$225,880.06 | \$575,554.49 | \$238,895.12 | \$588,569.52 | \$251,910.15 | \$602,741.46 | \$266,082.09 |
| Year 24 | \$346,759.15 | | \$521,305.37 | \$174,546.22 | \$532,049.50 | \$185,290.35 | \$543,369.69 | \$196,610.54 | \$554,094.10 | \$207,334.95 | \$566,903.80 | \$220,144.65 | \$579,415.61 | \$232,656.46 | \$592,821.12 | \$246,061.97 | \$606,226.61 | \$259,467.46 | \$620,823.71 | \$274,064.56 |
| Year 25 | \$357,161.92 | | \$536,944.53 | \$179,782.61 | \$548,010.98 | \$190,849.06 | \$559,670.78 | \$202,508.86 | \$570,716.93 | \$213,555.01 | \$583,910.92 | \$226,749.00 | \$596,798.08 | \$239,636.16 | \$610,605.75 | \$253,443.83 | \$624,413.41 | \$267,251.49 | \$639,448.42 | \$282,286.50 |
| Year 26 | \$367,876.78 | | \$553,052.87 | \$185,176.09 | \$564,451.31 | \$196,574.53 | \$576,460.91 | \$208,584.13 | \$587,838.43 | \$219,961.65 | \$601,428.25 | \$233,551.47 | \$614,702.02 | \$246,825.24 | \$628,923.93 | \$261,047.15 | \$643,145.81 | \$275,269.03 | \$658,631.87 | \$290,755.09 |
| Year 27 | \$378,913.09 | | \$569,644.45 | \$190,731.36 | \$581,384.85 | \$202,471.76 | \$593,754.73 | \$214,841.64 | \$605,473.59 | \$226,560.50 | \$619,471.09 | \$240,558.00 | \$633,143.08 | \$254,229.99 | \$647,791.64 | \$268,878.55 | \$662,440.18 | \$283,527.09 | \$678,390.83 | \$299,477.74 |
| Year 28 | \$390,280.48 | | \$586,733.79 | \$196,453.31 | \$598,826.40 | \$208,545.92 | \$611,567.38 | \$221,286.90 | \$623,637.79 | \$233,357.31 | \$638,055.23 | \$247,774.75 | \$652,137.38 | \$261,856.90 | \$667,225.39 | \$276,944.91 | \$682,313.39 | \$292,032.91 | \$698,742.55 | \$308,462.07 |
| Year 29 | \$401,988.89 | | \$604,335.80 | \$202,346.91 | \$616,791.19 | \$214,802.30 | \$629,914.40 | \$227,925.51 | \$642,346.93 | \$240,358.04 | \$657,196.88 | \$255,207.99 | \$671,701.50 | \$269,712.61 | \$687,242.16 | \$285,253.27 | \$702,782.79 | \$300,793.90 | \$719,704.83 | \$317,715.94 |
| Year 30 | \$414,048.56 | | \$622,465.88 | \$208,417.32 | \$635,294.92 | \$221,246.36 | \$648,811.83 | \$234,763.27 | \$661,617.34 | \$247,568.78 | \$676,912.79 | \$262,864.23 | \$691,852.54 | \$277,803.98 | \$707,859.42 | \$293,810.86 | \$723,866.27 | \$309,817.71 | \$741,295.97 | \$327,247.41 |
| | \$8,359,000.53 | | \$12,566,624.06 | \$4,207,623.53 | \$12,825,622.72 | \$4,466,622.19 | \$13,098,508.17 | \$4,739,507.64 | \$13,357,031.55 | \$4,998,031.02 | \$13,665,823.12 | \$5,306,822.59 | \$13,967,433.65 | \$5,608,433.12 | \$14,290,587.76 | \$5,931,587.23 | \$14,613,741.39 | \$6,254,740.86 | \$14,965,620.11 | \$6,606,619.58 |

* Developer proposes three percent (3%) PILOT payments year-over-year. Cap rate calculations assume three percent (3%) increases year-over-year.

RESOLUTION NO.: _____ - 2026

OF

MAY 11, 2026

**A RESOLUTION AUTHORIZING THE CITY MANAGER TO EXECUTE
A LICENSE AGREEMENT WITH NEWBURGH SANCTUARY, INC.
TO ALLOW ACCESS TO CITY-OWNED PROPERTY KNOWN AS CRYSTAL LAKE
(SECTION 41, BLOCK 2, LOT 11.2) FOR ACCESS RELATED TO
THE BLUEBLOCKS FLOATING GARDENS PROJECT**

WHEREAS, Newburgh Sanctuary, Inc. has requested access to City-owned property known as Crystal Lake, being more accurately described as Section 41, Block 2, Lot 11.2 on the official tax map of the City of Newburgh, for the purpose of installing three Blueblocks Floating Gardens (the “Project”) under permit(s) duly authorized and issued by the New York State Department of Environmental Conservation in Crystal Lake in the City of Newburgh; and

WHEREAS, such access to the City-owned property requires the parties to execute a license agreement, a copy of which is attached hereto and made a part of hereof; and

WHEREAS, this Council has reviewed such license agreement and has determined that entering into the same would be in the best interests of the City of Newburgh;

NOW, THEREFORE, BE IT RESOLVED, by the Council of the City of Newburgh, New York that the City Manager be and he is hereby authorized to enter into the attached license agreement with Newburgh Sanctuary, Inc. to allow access to City-owned property known as Crystal Lake for the purpose of installing three Blueblocks Floating Gardens in Crystal Lake in the City of Newburgh and to execute the permit application required by the New York State Department of Environmental Conservation.

LICENSE AND ACCESS AGREEMENT

This License and Access Agreement (“Agreement”) is entered into this ____ day of _____, 2026 (the “Execution Date”), by and between the City of Newburgh, New York (the “City” or the “Licensor”), a New York State municipal corporation, having an address of 83 Broadway, Newburgh, New York 12550 and Newburgh Sanctuary, Inc. (Licensee), a non-profit corporation duly organized and existing under the laws of the State of New York, having an address at 130 Third Street, Newburgh, New York 12550, and where Licensor and Licensee are collectively referred to herein as the “Parties”.

WHEREAS, the Licensee, including its volunteers, employees, contractors or agents, proposes to install three Blueblocks Floating Gardens (the “Project”) under permit(s) duly authorized and issued by the New York State Department of Environmental Conservation in Crystal Lake in the City of Newburgh; and

WHEREAS, for the purpose of installing and maintaining the Blueblocks Floating Gardens, Licensee requests access to City-owned property known as Crystal Lake, located at 60 Temple Avenue, Newburgh, New York (Section 41, Block 2, Lot 11.2) (hereafter “City Property”) subject to the conditions provided below, to allow the Licensee to manage the Project at the City Property.

NOW, THEREFORE, in consideration of the mutual covenants and agreements hereinafter set forth, and other good and valuable consideration, the receipt and adequacy of which are hereby acknowledged, the Parties agree as follows:

1. Right of Access. For the term of this Agreement, Licensor grants to Licensee, in accordance with the conditions set forth herein, a license to enter upon, access, and otherwise use, the City Property for the purpose of installing and maintaining the Project (the “Right of Access”). Licensee's Right of Access applies to Licensee’s employees, volunteers, and consultants as may be necessary to complete the Project. The Right of Access does not constitute a grant of any ownership, leasehold, easement, or other property interest whatsoever in any portion of the City Property.
2. Term. This Agreement shall commence on execution and expire and terminate on December 31, 2027, unless modified by the Parties as set forth in Section 11 of this Agreement.
3. Activities to be Performed on the City Property. In order to complete the Project, Licensee's activities will include, but will not be limited to, the assembly, launch/installation, maintenance, and removal of three six foot deep (approx.) by five foot in diameter (approx.) floating, native aquatic plant-filled garden docks (the “Project Activities”). The Project Activities shall be consistent with the Project Overview attached hereto as Exhibit “A”.
4. Conditions of Access.
 - 4.1. Minimum Disturbance. Reasonable wear and tear expected, Licensee shall carry out all Activities with all reasonable measures to avoid damage to the City Property. Licensee

shall carry out all Project Activities with all reasonable measures to avoid accident, damage or harm to persons or property.

4.2. Hours of Access. All access to the City Property by Licensee and its designated representatives to conduct Project Activities will occur between the hours of 8:00 a.m. and 6:00 p.m., unless otherwise authorized in advance by Licensor in writing.

4.3. Licensor Access. Licensor reserves the right to be present and to monitor Project-related activities, through employees or other agents, and otherwise access the City Property during the length of this Agreement. Licensor shall have the ability to issue a stop work order if any ongoing or proposed work presents a threat to the City Property.

4.4. Restoration. Upon completion of the Project, Licensee will restore the City Property as near as practicable to its condition immediately prior to the commencement of the Project.

4.5. Special Considerations Specific to License.

4.5.1. Licensee shall comply with the conditions of New York State Department of Environmental Conservation Lakes and Shorelines General Permit (GP-0-25-007). Draft NYSDEC Application for General Permit Coverage and DEC Authorization attached hereto as Exhibit "B".

4.5.2. Licensee shall only access the City Property from the existing site entrance at the intersection of Temple Avenue and Beach Street, and into the waterbody of Crystal Lake from the existing boat launch located at the northeast corner of the Lake.

5. Insurance and Bond.

5.1. Licensee shall not permit any employees, agents, volunteers, contractor or subcontractor to commence or perform work nor operate machinery under this Agreement until it has obtained all insurance required under this Section 5 and such insurance has been submitted to the Licensor.

5.2. Workers' Compensation and Disability Benefits Insurance – Licensee shall require all contractors and sub-contractors to take out and maintain during the life of this agreement such Workers' Compensation and Disability Benefits Insurance for its employees or members to be assigned to the work hereunder as may be required by New York State Law.

5.3. General Liability and Property Damage Insurance – Licensee shall require all contractors and subcontractors to take out and maintain during the life of this agreement such general liability and property damage insurance as shall protect it and the City which shall be named as additional insured on all such policies from claims for damages for personal injury including accidental death, as well as from claims for property damage, which may arise from operations under this agreement in an amount not less than \$1,000,000.00 for injuries including wrongful death to any one person and subject to the same limit for each

person, and property damage in an amount not less than \$100,000.00 on account of any one occurrence. Licensee shall furnish the above insurance to the Licensor and shall also name the Licensor as an additional named insured in said policies. Such insurance shall be maintained in force during the entire term of this Agreement.

5.4. Licensee may retain certain employees, agents, volunteers, contractors and consultants to perform the subject work. In the contract by which Licensee retains such agents, volunteers, contractors and consultants, Licensee and such agents, volunteers, contractors and consultants shall provide and maintain insurances as required by this Section and include the City of Newburgh as additional insured under insurance coverage concerning Licensee's performance of the work referenced herein.

6. Compliance with Laws. Licensee shall comply with federal, state and local laws applicable to any activity in which Licensee engages while Licensee is on the City Property.

7. Representations.

7.1. Licensor.

7.1.1. In consideration of the commitments and obligations made by the Parties in this Agreement, Licensor represents that it has received payment in the amount of one (1) dollar as of the Execution Date.

7.1.2. Licensor represents that it has the power and authority to grant the License and Right of Access described in this Agreement.

7.1.3. Licensor represents that it has the power and authority to sign New York State Department of Environmental Conservation Lakes and Shorelines General Permit (GP-0-25-007).

7.2. Licensee.

7.2.1. Licensee represents that it has the power and authority to enter into this Agreement.

7.2.2. Licensee represents that it has the power and authority to sign New York State Department of Environmental Conservation Lakes and Shorelines General Permit (GP-0-25-007).

8. Assignment. This Agreement may not be assigned or sub-licensed to any other person or entity.

9. Indemnity. Licensee agrees to indemnify and hold harmless the Licensor from any and all claims, damages, suits, actions, proceedings, losses and expenses (collectively, referred to as "claims") which may be incurred or awarded against the Licensor or its designated representative arising from the access granted to Licensee and its designated representatives. Said indemnification includes all costs of defense of any action brought against the Licensor or its designated representative. Licensee may agree to retain counsel of its choosing to handle

the defense of such action. Before any settlement may be agreed upon by Licensee, it will submit the proposed settlement to the Licensor for its concurrence. Licensor agrees to provide all litigation papers to the Licensee. Excepted from this indemnification are claims arising from any intentional tortious or grossly negligent act of the Licensor or its designated representative or any claim unrelated to the access granted to Licensee and its designated representatives. The indemnification obligations contained in this paragraph shall survive this Agreement.

10. Modification of Agreement. This Agreement may be supplemented, amended, or modified only by the mutual agreement of both Parties. No supplement, amendment, or modification of this Agreement shall be binding unless it is in writing and signed by the Parties.
11. Termination. Licensor may terminate this Agreement for cause at any time with 5 days' written notice to Licensee. If Licensor exercises its right to terminate, Licensor agrees that it will hold harmless Licensee for removal of, in a reasonable manner and time, persons or property that were present for purposes of the Project in accordance with this Agreement.
12. General Provisions.
 - 12.1. Waiver. No waiver by either party of any failure to comply with this Agreement shall be deemed a waiver of any other or subsequent failure to so comply.
 - 12.2. Severability. If any provision of this Agreement or its application to any person or circumstance shall, to any extent, be invalid or unenforceable, the remainder of this Agreement, or its application to persons or circumstances other than those as to which it is held invalid or unenforceable, shall not be affected thereby, and each provision of this Agreement shall be valid and enforceable as permitted by law.
 - 12.3. Entire Agreement. This Agreement represents the full, complete and entire agreement between the Parties with respect to the subject matter hereof. There are no other understandings, oral or written, related to the subject matter of this Agreement.
 - 12.4. This Agreement may be executed with original signatures in counterparts, or by facsimile or PDF-scanned signatures in counterparts, which will be deemed legally binding as fully as an original signature.
 - 12.5. Governing Law. This Agreement and the rights and obligations hereunder shall be construed in accordance with, and be governed by, the laws of the State of New York.

THE REMAINDER OF THIS PAGE INTENTIONALLY LEFT BLANK
[Signature Page to Follow.]

Signature Page

License Agreement: City of Newburgh with Newburgh Sanctuary, Inc.

IN WITNESS WHEREOF, the Parties have caused their duly authorized representatives to execute this Agreement as of the Execution Date.

WITNESSETH:

THE CITY OF NEWBURGH
LICENSOR

By: _____
Jason Morris, Interim City Manager
Per Resolution No.:

NEWBURGH SANCTUARY, INC.
LICENSEE

By: _____
Name: _____
Title: _____

Approved as to form:

MICHELLE KELSON, Corporation Counsel

NANCY BLOOM, City Comptroller



thread
collective



Initiative

Crystal Lake, Newburgh April 5th 2026

BlueBlocks Floating Gardens are a modular system designed for education, restoration, and to inspire stewardship in our shared waterways. Inspired by lily pads, they are built entirely of salvaged and reclaimed materials, and float on a bed of recycled corks. Designed as a kit, they are easily assembled, launched and stewarded by community members.

site plan

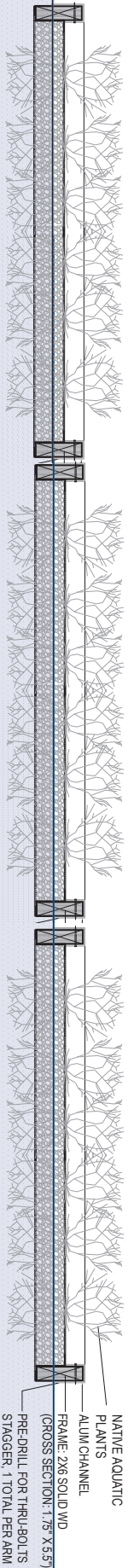
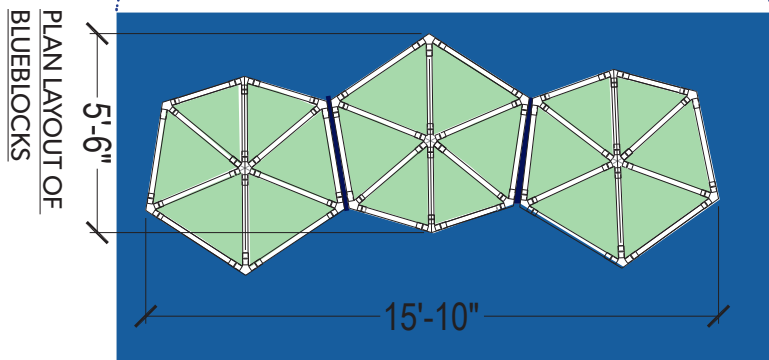
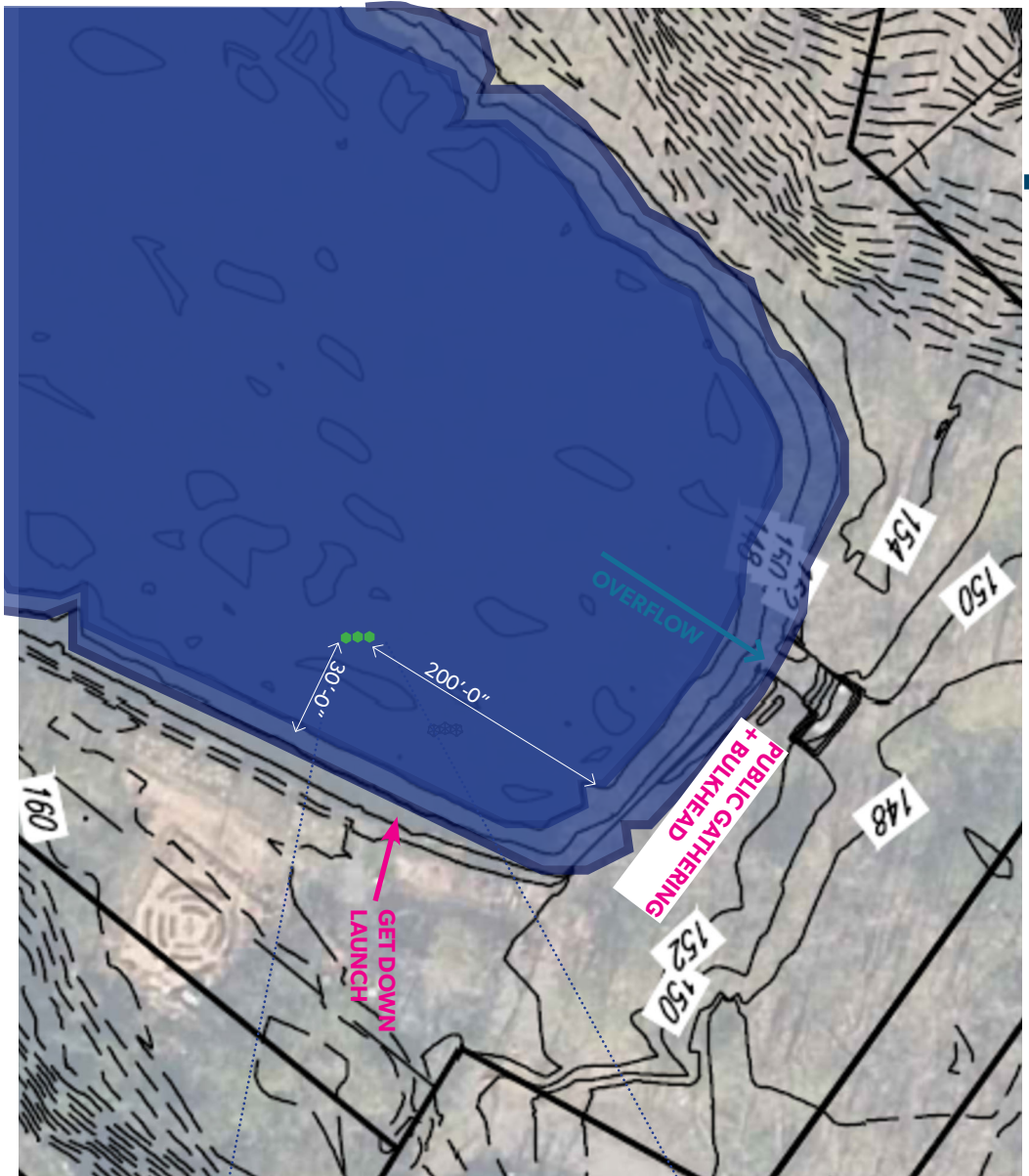

SECTION



1. View North (early spring)



2. View North-West (fall)



3. View East (fall)



4. View South (fall)

Product specifications



PRODUCT NAME

BlueBlocks Garden

WEIGHT

approx 300 lbs dry / 500lbs wet

COLOR

Natural wood or concrete

Frame may be painted with non-toxic paint

FORMAT

Buoyant marshland

DIMENSION

APPROX 5FT DIA.,

FRAME DEPTH - 6-8"

MATERIALS

- Frame: wood sourced from salvaged materials Or cast in low-carbon biophilic concrete
- Connectors for wood from: welded aluminum corner connectors
- Fisherman's netting
- 8,000 corks, salvaged source
- Fasteners, stainless steel or gal. aluminum
- BlueSteel 8 braid rope
- Anchor: low-carbon biophilic concrete
- Plants: Freshwater wetland varities

KNOWN ISSUES

- Netting may fail over time and need repair.
- Plants may not survive, requiring maintenance and new additional plants to be added in the second season
- Ducks and water-birds will likely nest on the gardens, consume grasses, requiring maintenance
- Debris may collect within the gardens depending on water flow and wave action requiring maintenance.

PRODUCT TESTING

Product has been tested in SALT AND FRESH WATER, in bays, rivers, and ponds. with great success.

PRODUCT IMAGES



technological details

plan of a single unit, not to scale,
each unit is approx 5'-6" x 5'-6"

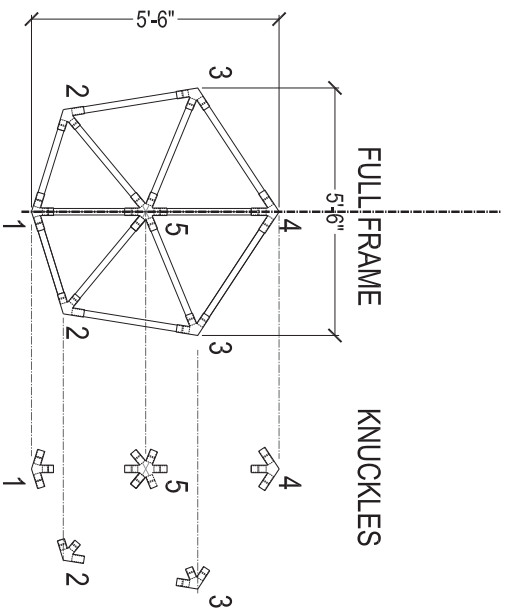

1 PLAN
1/2" = 1'-0"

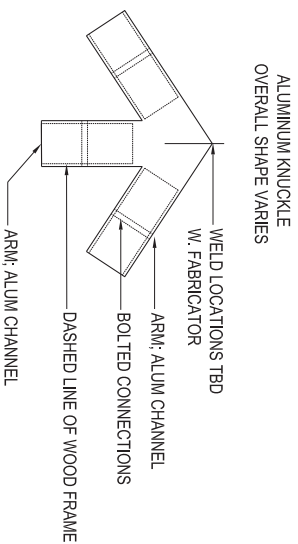

| 5 KNUCKLES TOTAL | |
|------------------|--|
| TOTAL COUNT | |
| TYPE 1 = 2 | |
| TYPE 2 = 2 | |
| TYPE 3 = 2 | |
| TYPE 4 = 1 | |
| TYPE 5 = 1 | |

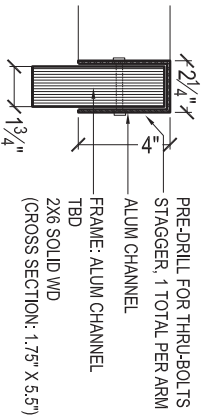

1 DETAILS
3" = 1'-0"

LEGEND

1. External frame, salvaged wood, untreated
2. Cork flotation mat, 8,000 corks
3. Fish netting, top and bottom
4. Aquatic plants
5. Anchor line
6. Danforth anchor
7. Waterway



thread collective

plant palette

sweet water

The plant palette will be selected in partnership with the community team to ensure it reflects the goals identified for restoration, education, and habitat. Following are plants that have thrived in the past as recommendations for consideration.

Aquatic plants are the engineers of water bodies. Rooted or floating, emergent or submerged, they filter pollutants, stabilize sediments, and soften the force of waves and currents. Their stems and leaves create shelter for fish, invertebrates, and birds, turning open water into layered, living space. Through photosynthesis they oxygenate water and absorb excess nutrients, helping to prevent algal blooms and improve overall water quality. Beyond ecology, aquatic plants carry cultural and aesthetic value, marking seasonal change and offering visual cues of a water body's health. When they thrive, they signal balance; when they disappear, it often reveals deeper stress within the aquatic system.

Crystal Lake is a freshwater body, a part of the Quassaick Creek Watershed.



Asclepias incarnata
Swamp Milkweed, Pink Milkweed

The large, bright, terminal blossoms of this tall, perennial are made up of small, rose-purple flowers. Deep pink flowers clustered at the top of a tall, branching stem, bearing numerous narrow, lanceolate leaves. Opposite, narrow, lance-shaped leaves line the erect, open-branched stem. Elongated, tan-brown seed pods persist into winter.

The juice of this wetland milkweed is less milky than that of other species. The genus was named in honor of Aesculapius, Greek god of medicine, undoubtedly because some species have long been used to treat a variety of ailments. The Latin species name means "flesh-colored."



Lobelia Cardinalis

Late-summer stunner, growing well in moist, sandy soils in sun to partial shade. Its incredible red flowers attract more than just human eyes--it's also a great pollinator plant for bees, butterflies and hummingbirds

Cardinal Flower is a hummingbird favorite that adds a vibrant red hue to your garden. It produces lobeline which helps to naturally deter pests, but can also be mildly toxic to humans and pets. While parent plants have a limited lifespan, they generously self-seed and grow rapidly, ensuring a continual display of beauty.

plant palette

sweet water



Juncus effusus
common soft rush

Occurs only in wetlands. Various Native American peoples used common soft rush for tying, binding and weaving.

Considered a wetland plant, but can thrive in medium soils. Its leafless stems are bright to dark green and tubular, tapering from a base about 1/16" in diameter to an average height of 2'. Its flowers poke out of a slit near the slender tip. Common Rush actively grows during the spring and fall when soil temperatures are cool.



Carex comosa
Bottle Brush Sedge

Narrow green foliage growing up to 24" crowned with delicate flowers that are light to deep-blue (purple and violet are not uncommon) with yellow-whitish markings at the base of the sepals. Blue Flag Iris blossom from May to July, is perfect for naturalizing as well as wetland filters.

Blue flag can be cut and the rhizomes can be dug up, but physical control is difficult.



Acorus americanus
Sweet flag

Occurs only in wetlands. Its preferred habitat is mucky shorelines and shallows, often making its home in up to a foot of water.

Various Native American peoples used common soft rush for tying, binding and weaving. Sweet Flag is easily distinguished by the pleasant fragrance given off when the leaves are broken. Sweet flag is of ancient stock. It is likely that Native Americans played a significant role in the distribution of Sweet Flag, as it was used in ceremonies, medicines, and for trade. Disjunct populations have been noted to occur in areas that are often near old village sites and camping areas.

previous installations at Eagle Pond, Cape Cod



- Community Contributions:
- Agway - native plant procurement
- Mullen Construction - labor consultation and tools
- Corks - local restaurant donations
- Graham Construction - Lumber donation for frame
- Town of Barnstable: Marine & Environmental Affairs: Anchor/Mooring Assistance



circular economy

A low-impact resource supply chain for the BlueBlocks Gardens. The gardens are buoyant due to 12,000 corks in each garden which are collected from across the city through a collection program that recycles wine corks

LEGEND

- 1 Salvaged wood sourced locally
- 2 Natural coir for planters
- 3 Sea-grasses, *Spartina alterniflora*
- 4 Planters for garden
- 5 Reef Blocks for anchors
- 6 Wine corks, salvaged



1



2



3



4



6

#everycorkcoun
 RETI BLUEBLOCK GARDENS ARE STUFFED WITH CORK TO KEEP THEM AFOAT!
 BRING YOUR CORKS TO THE REGATTA!
 drop off cork TRASHING, 701 Columbia Street Red Hook, BRL
 DM for more details

ETI
 enter
 thread collective



Application for General Permit Coverage and DEC Authorization

Applicant Information: DEC ID (if known): _____

| | | | |
|--|--|--|--|
| Name of Applicant: Newburgh Sanctuary Applicant must be <input type="checkbox"/> property owner, <input checked="" type="checkbox"/> lessee or <input type="checkbox"/> operator (check which applies). Email Address: sanctuary.crystallake@gmail.com Phone: 917-309-4506 Mailing Address: 130 3rd Street City: Newburgh State: NY Zip: 12550 | | | |
| Name of Property Owner (if different from applicant): City of Newburgh Email Address: Phone: City of Newburgh Mailing Address: 83 Broadway City: Newburgh State: NY Zip: 12550 | | | |
| Application Contact or Contractor (if applicable): Email Address: sanctuary.crystallake@gmail.com Phone: 917-309-4506 Mailing Address: 130 3rd Street City: Newburgh State: NY Zip: 12550 | | | |
| Project Location (where work will be done): Town (where property taxes paid): City of Newburgh County: Orange County Street Address: 61 Temple Ave City: Newburgh State: NY Zip: 12550 | | | |

Short Description (short description of work proposed):

Installation of three Blueblock Floating Gardens: The BlueBlocks Initiative is a community-led water restoration project using floating, native aquatic plant-filled garden docks to clean polluted water, prevent harmful algal blooms, and restore shoreline ecosystems. These layered floating gardens create habitat above and below the water while improving oxygen levels and water clarity over time, supporting long-term ecological health and resilience of local lakes. Each floating garden is 5X6 in diameter.

Proposed Start Date and Completion Date

Proposed start date: 5/10/26 Proposed completion date: 12/01/26

Tree Clearing Restrictions

If tree clearing is required for the proposed project, check the box below that applies to your project:

- I am able to comply with tree clearing restrictions in Condition 7 of this General Permit:
 Clearing prohibited between March 1 and November 30 in Nassau and Suffolk Counties;
 Clearing prohibited between April 1 and October 30 in rest of New York State.
- I am unable to comply with tree clearing restrictions in Condition 7 of this General Permit and I propose to clear trees between _____.

Shoreline Categorization (see permit condition 4 and application instructions):

- Hard bottom or inorganic material
- Muddy, organic bottom

✓ **Type of Project and Project Approval Process**

For project types requiring a **Notice of Intent (NOI)**, if DEC does not contact you regarding any environmental concerns or missing information within 10 business days of DEC's receipt¹ of the Application Form and all required attachments, the project may proceed without further approval. Otherwise, the project may not proceed until concerns are resolved. This would include failure to provide all required application attachments.

For project types requiring a **DEC Countersignature**, the project may not proceed until a copy of the general permit that has been validated with a DEC countersignature, is received by the permittee.

In the table below, indicate which activity(ies) are being proposed and whether they will be located in freshwater wetlands or freshwater wetland adjacent area. Check all that apply.

| Authorized Activities | | |
|---|-------------------------------------|-------------------------|
| Activity 1: Shoreline erosion protection utilizing bioengineering approaches, including but not limited to regrading of the shoreline and replanting with conservation species such as live stakes of native woody vegetation and deep-rooted native herbaceous plants, installation of brush mats, and planting vegetation to provide shoreline habitat. | <input type="checkbox"/> | DEC Countersignature |
| Activity 2: Shoreline installation of new riprap structures of 150 linear feet or less where erosion is evident. | <input type="checkbox"/> | DEC Countersignature |
| Activity 3: Replacement or repair of existing functional riprap, bulkheads (including refacement and toe protection), and other bank stabilization structures substantially within the existing structural footprint. | <input type="checkbox"/> | DEC Countersignature |
| Activity 4: Shoreline installation of new stepped block walls of 150 linear feet or less above the Mean High Water elevation with toe protection (riprap) in front of the wall at or below Mean High Water elevation where erosion is evident. | <input type="checkbox"/> | DEC Countersignature |
| Activity 5: In-kind replacement or repair of existing boat or access ramps below the Mean High Water elevation. Precast concrete or work in the dry is required. | <input type="checkbox"/> | NOI |
| Activity 6: Installation of new, single lane boat/access ramps up to 20 feet wide, with a total work area width less than 30 linear feet, as measured along the shoreline, or modifications of existing boat or access ramps with no greater than a 50% increase in the area of the ramp. Precast concrete ramps or work in the dry is required. | <input type="checkbox"/> | DEC Countersignature |
| Activity 7: In-kind repair or replacement of existing functional boat houses, docks, platforms, or similar over-water structures within the same structural footprint. Non-water dependent structures, such as the residential conversion of boat houses, storage areas, etc., are not authorized. | <input checked="" type="checkbox"/> | NOI |
| Activity 8: Installation of a new residential dock where no dock already exists on the property, or modification of an existing dock, with a total surface area of 400 square feet or less, that does not require dredging for navigational access. Authorized docks must be constructed on open or floating supports and not exceed four feet in width, except that widths of up to six feet may be authorized where open grated deck material is used. Coverage for one open, frame-supported boat lift per dock is also authorized under this general permit. | <input type="checkbox"/> | NOI |

Continued on next page

¹ Receipt of electronic files is the date received on any business day from midnight to 4:45 p.m., or the next business day if received any other time. For example, for a project application received by DEC at 4:30 p.m. on Thursday, May 1 work may commence after close of business on Thursday, May 15 if DEC does not contact the applicant regarding any environmental concerns or missing information.

| Authorized Activities <i>continued</i> | | |
|---|--------------------------|-------------------------|
| Activity 9: Demolition of existing structures and removal of structural fill below Mean High Water elevation and from freshwater wetlands and freshwater wetland adjacent areas. | <input type="checkbox"/> | NOI |
| Activity 10: Maintenance dredging of existing residential dockage or marina facilities to maintain water-dependent uses, occurring at least once every 10 years and not exceeding 2,500 square feet. | <input type="checkbox"/> | DEC Countersignature |
| Activity 11: New navigational dredging activities around existing docking facilities (residential or commercial) of 1,250 square feet or less to maintain water-dependent uses. | <input type="checkbox"/> | DEC Countersignature |
| Activity 12: Installation or maintenance of dry hydrants for fire protection. | <input type="checkbox"/> | NOI |
| Activity 13: Installation of new or replacement residential water intake lines or beach wells, infiltration galleries, and prefabricated sand filters designed to protect individual residential water intakes. | <input type="checkbox"/> | DEC Countersignature |
| Activity 14: Physical, non-mechanized removal of rooted, submerged or floating aquatic vegetation from around existing docking facilities to maintain open-water access and water-dependent uses, from a total area not to exceed 1,500 square feet. | <input type="checkbox"/> | NOI |

✓ **Required Attachments** (check each box to indicate that the attachment is provided with this form):

All Projects



- Project Location Map (with location marked)
- Project Site Photographs
- Project Plans – Overhead view (plan view):
 - Dimensions of existing and proposed structures (total length, width, and height)
 - Location of existing and proposed structures, labeled accordingly
 - Erosion, sedimentation, and turbidity controls
 - Location of the Mean High Water Elevation
 - A minimum of two benchmark measurements illustrating distances measured from the lakeward face of the existing and proposed structures to permanent objects on the property to indicate the extent of work
 - When applicable, site location map for disposal of dredged material or aquatic vegetation
- Project Plans – Side view (Cross-section):
 - Locations and dimensions of existing and proposed structures
 - Labels indicating the type(s) of materials being used
 - Mean High Water Elevation
 - Embedment of structures (where applicable, erosion protection structures shall be embedded a minimum of one foot into substrate to prevent undercutting)

As Applicable (see instructions)

- State Environmental Quality Review Documentation (copy of Negative Declaration or Notice of Acceptance of Final Environmental Impact Statement, as applicable)
- State Historic Preservation Act Documentation, as applicable.
- Justification for waterward encroachment – for projects seeking authorization under Authorized Activity 3 that include waterward encroachment, explain why a replacement or repair within, or landward of, the existing structural footprint is not possible or feasible.
- Justification to Waive or Alter Tree Cutting Restrictions – for projects unable to meet tree cutting restrictions in Permit Condition 7.

Certification:

I hereby apply for authorization under General Permit GP-0-25-007. I have read General Permit GP-0-25-007 and will construct and operate this project in strict compliance with the approved plans and terms and conditions of this permit as well as the Environmental Conservation Law and applicable regulations. I understand that any false or inaccurate statements made in the application for this permit are punishable as a Class A misdemeanor. As a condition of this permit, I accept full legal responsibility for all damage, direct or indirect, of whatever nature, and by whomever suffered, arising out of the project described herein and agree to indemnify and save harmless the state from suits, actions, damages, and costs of every name and description resulting from this project. I hereby consent to Agency inspection of the project site and adjacent areas on the property. Agency staff may enter the property without notice between 7:00 am and 7:00 pm, Monday - Friday. Inspection may occur without the owner, applicant or agent present. If the property is posted with "keep out" signs or fenced with an unlocked gate, Agency staff may still enter the property. Agency staff may take measurements, analyze site physical characteristics, take soil and vegetation samples, sketch and photograph the site. I understand that failure to give this consent may result in denial of the permit(s) sought by this application.

| | | | |
|---|---------------|---|---------------|
|  Betty Bastidas <small>Digitally signed by Betty Bastidas Date: 2026.04.05 14:58:11 -04'00'</small> | 4/6/26 |  | |
| _____ Applicant Signature | _____ Date | _____ Property Owner Signature (if different than applicant) | _____ Date |

**Lakes and Shorelines General Permit (GP-0-25-007)
DEC Authorization Determination**



Department of
Environmental
Conservation

PROJECT AUTHORIZATION BY NYSDEC - This Page for NYSDEC Use Only

The project described in the Application for General Permit Coverage requires Notice of Intent (NOI) submission and is AUTHORIZED for coverage under General Permit GP-0-25-007 Lakes and Shorelines.

This authorization is for Authorized Activity Number(s):

The project described in the Application for General Permit Coverage requires NOI submission and is NOT AUTHORIZED for coverage under General Permit GP-0-25-007 Lakes and Shorelines. Additional explanation:

The project described in the Application for General Permit Coverage requires a countersignature and is AUTHORIZED by the DEC countersignature below for coverage under General Permit GP-0-25-007 Lakes and Shorelines.

This authorization is for Authorized Activity Number(s):

Additional explanation:

The project described in the Application for General Permit Coverage requires a countersignature and is NOT AUTHORIZED for coverage under General Permit GP-0-25-007 Lakes and Shorelines.

Additional explanation:

NYSDEC Signature

Authorized Signature: _____ Date: 4/6/26
Printed Name: _____ DEC ID: _____
Title: _____ Region: _____

If Permit Coverage is Authorized:

Time of Year Restrictions: Tree Removal Prohibited Between
March 1-November 30 (Nassau and Suffolk counties) April 1-October 31(All other NYS Counties)
Other:

Time of Year Restrictions: In-water Work Prohibited Between
November 1-August 31 (tidal portions of Hudson River)
Other (per condition 10):

Authorization Type(s)
6 NYCRR 608; Article 15, Protection of Waters
Docks, Platforms & Moorings Excavation & Fill Stream Disturbance
6 NYCRR 663; Article 24, Freshwater Wetlands

Permit Coverage Effective Permit Coverage Expiration
Date: Date:

Distribution and Attachments

Distribution: Regional DEP Regional BEH USACE Other(s): _____
Attachments: General Permit Project Location Map Project Plans
Other(s): _____

RESOLUTION NO.: _____ - 2026

OF

MAY 11, 2026

**A RESOLUTION OF THE CITY COUNCIL OF THE CITY OF NEWBURGH
AFFIRMING ITS WILLINGNESS AND INTENT
TO JOIN THE FEDERAL HIGHLANDS CONSERVATION ACT REGION**

WHEREAS, the Highlands region, encompasses more than three million acres of Pennsylvania, New York, New Jersey, and Connecticut; and

WHEREAS, the Highlands region is an area of national significance, possessing substantial natural beauty, containing contiguous forest and productive farmland, numerous cultural and historic sites, plentiful recreation opportunities, and the protection and supply of important drinking water sources for over fifteen million people; and

WHEREAS, the U.S. Congress, in bipartisanship, passed the Highlands Conservation Act, Public Law 10-421 that was signed into law by the President of the United States on November 30, 2004, designating the Highlands as a significant national conservation priority region; and

WHEREAS, the Highlands Conservation Act authorizes the Secretary of the Interior and the Secretary of Agriculture to provide financial assistance to Highlands States to preserve and protect high priority conservation land in the Highlands region; and

WHEREAS, the United States Fish and Wildlife Service manages a voluntary grant program to assist Highlands States, local units of government, and private forest and farm landowners in the conservation of land and natural resources in the Highlands region in coordination with willing sellers; and

WHEREAS, land preservation efforts in the Highlands region should link the parks, historic sites, wetlands, wildlife habitats, streams, rivers, reservoirs, watershed, trails, scenic and natural lands and other protected areas unique to the region for the enjoyment of future generations; and

WHEREAS, the City of Newburgh, New York is eligible for inclusion in the federal Highlands Conservation Act region to become eligible for future grant funding; the same being in the best interests of the City of Newburgh;

NOW THEREFORE BE IT RESOLVED that the City Council of the City of Newburgh hereby affirms and supports the City of Newburgh, New York being officially included in the federal Highlands boundary, as maintained by the U.S. Fish and Wildlife Service for the Highlands Conservation Act grant program, thereby qualifying for financial and technical assistance provided by the U.S. Congress.

Land Conservation Funding Opportunity through the Highlands Conservation Act

Summary

The Highlands Conservation Act grant program provides funding to states and municipalities for the protection of water, habitat, agricultural resources, and park lands. Your town is not currently included in the area eligible for funding.

Background

The Highlands region spans 3.4 million acres across Connecticut, New York, New Jersey, and Pennsylvania. The Highlands Conservation Act was passed in 2004, founding the Highlands Conservation Act grant program to protect clean drinking water, healthy forests, thriving wildlife populations, productive agriculture, and abundant recreational opportunities. Since then, it has brought in over \$80 million in conservation funding to Highlands communities resulting in the permanent protection of over 16,000 acres. The grant program is administered by the U.S. Fish and Wildlife Service (USFWS).

Recent changes

The Highlands Conservation Act was recently reauthorized with some significant changes:

Expanding who is eligible for funding

Before reauthorization, only state agencies like NY State Parks (OPRHP) and the Department of Environmental Conservation (DEC) were eligible for funding. Now, municipalities are also eligible recipients.

Expanding what areas are eligible

Prior to reauthorization, only areas in blue shown on the map were eligible for funding. Now, towns (including yours) in the pink area can be added to the eligible area.

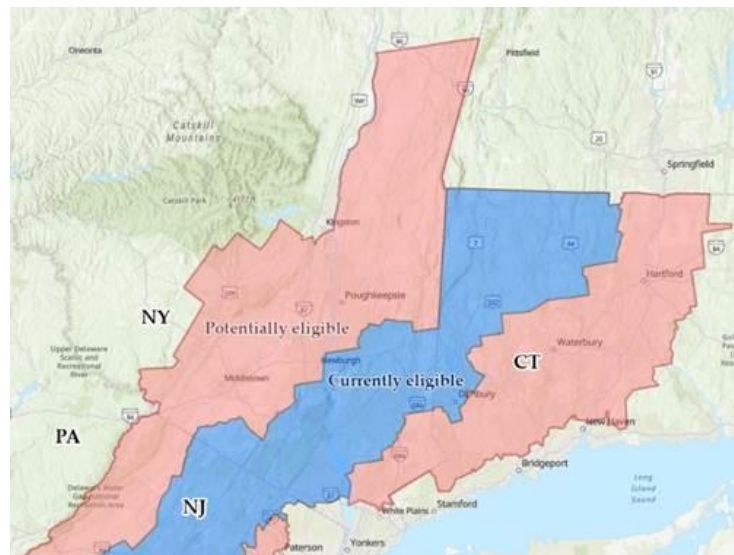

Action needed to become eligible

If your town would like to be included in the area eligible for HCA funding, the Town Board can pass a resolution stating its willingness and intent to be added to the federal Highlands Region. A sample resolution is provided along with this information sheet. No other action will be required by the Town.

Frequently Asked Questions

What does my town need to do?

To be added to the area eligible for federal grant funding, the Town Board needs to state through a resolution its willingness and intent to join the federal HCA region. No other action will be required.

Does this commit my town to anything?

No. It will enable your town to be eligible for federal grant funding only. It does not commit the town to applying for funding, nor does it guarantee the awarding of funding.

Would this impact the town's tax assessment or equalization rate?

No. Being included in the Highlands Region allows for the potential use of federal Highlands funding in efforts to protect property with willing landowners in the community. The funding passes through to qualified state, county or municipal government entities that will purchase conservation land (through ownership, conservation easement, or both in combination)

Does this add regulations or oversight in my town?

No. If your town is added to the Highlands Region, there will be no additional regulations or oversight, just the potential to access federal grant funding.

What parcels in my town can be protected using these funds?

Generally, large parcels with high conservation resource value are considered the most competitive for funding. The USFWS has criteria based on the Highlands conservation objectives that aids in determining what parcels can be protected. These criteria and accompanying map are currently being updated and expanded based on the 2022 reauthorization language to include new geographies.

What happens next?

Once a town passes a resolution indicating willingness to be added to the HCA region, the resolution will be forwarded to the NYS Office of Parks, Recreation and Historic Preservation (OPRHP). The State will make a recommendation to the U.S. Fish and Wildlife Service. The Director of U.S. Fish and Wildlife is highly likely to approve the expansion.

Is there a deadline or a window of opportunity to state my town's willingness to be added?

There is currently no deadline to indicate your willingness to be added to the Highlands boundary. We anticipate U.S. Fish and Wildlife Service will review requests periodically and add municipalities to the HCA territory in batches.

How can these funds be used to protect a specific property in my town?

Grant rounds are typically released annually with a due date in November. Grants are submitted and administered through NY State Parks (OPRHP), and the grant requires a 50% match. HHLT and other conservation groups are available as a resource to any town that wants to know more about grant funds for land protection in your area.

Where can I find more information about the Highlands Conservation Act grant program?

More information can be found here: <https://www.fws.gov/program/highlands-conservation-act-grant>

Additional questions? Contact Ted Warren, Public Policy Manager, Hudson Highlands Land Trust
845-424-3358 (ext. 5); edward.warren@hhl.org



Newburgh City Council

Greetings Ramona Monteverde (Ward 2),

We are writing in request of a ceremonial street dedication in the name of our former pastor, the late Dr. Ralph E. Harris. Dr. Harris has been deceased now for 25+ years.

Born in Shreveport LA, to the late Deacon Andrew Harris and Deaconess Mattie B. Harris, Dr. Harris was known near and far for his prolific preaching and capturing personality. In 1988, he was called to Newburgh NY to Pastor the Ebenezer Baptist Church. During his tenure as the senior pastor of Ebenezer Baptist Church, he had many contributions to the community, the city of Newburgh, and even the state of New York at large. Dr. Harris local accomplishments:

- Member of Newburgh City School District Advisory Council
- President of the Black Ministerial Fellowship
- Member of the Glenn E. Hines Memorial Boys/Girls Club
- Charter board member of "Project Life"
- Member of the Empire State Missionary Baptist Convention
- Board Member of Central Hudson Baptist Association
- Member of the National Baptist Convention USA

Name of person or group requesting the street name change

Ebenezer Baptist Church
Dr. Charl E. McRae II (Pastor)

Designated contact person, address, telephone number and email address

Adeline Hayes
76 First St.
Newburgh, NY 12550
(914) 213-4715
eah1222@aol.com

Location of proposed ceremonial street dedication, length of street to be affected, bounding streets or other boundaries

The joining Corner of First St. & Montgomery

Proposed ceremonial designation



The joining Corner of First St. & Montgomery

A Biography of the person to be honored:

Dr. Harris's journey began in Shreveport, Louisiana, where he was nurtured in a faith-filled home under the guidance of his father, Deacon Andrew Harris, and his mother, Deaconess Mattie B. Harris. His natural gifts as a preacher and his charismatic, yet principled persona earned him a broad following and a reputation for speaking truth to power with grace. In 1988, he accepted the call to lead Ebenezer Baptist Church in Newburgh, NY, embracing a ministry that extended far beyond the pulpit.

During his tenure as senior pastor, Dr. Harris actively engaged with the broader community. He lent his voice to education, youth development, and interfaith and interorganizational collaboration. He served on the Newburgh City School District Advisory Council, helped shape youth opportunities through the Glenn E. Hines Memorial Boys/Girls Club, and participated in a network of organizations that sought to uplift families and neighborhoods.

His leadership was characterized by a steady commitment to equity and opportunity. By guiding, mentoring, and organizing across faith and civic lines, he helped bring people together to address critical local issues. His influence extended to statewide networks, as he contributed to the Empire State Missionary Baptist Convention and the National Baptist Convention USA, reinforcing the role of church leadership in public service.

Dr. Harris's legacy is preserved in the ongoing work of the programs and partnerships he helped establish and in the memories of those who witnessed his dedication to the people of Newburgh. His life remains a testament to the power of faith-led civic engagement and fearless advocacy for the rights and dignity of all residents.

An explanation of the reason for the honorary designation

- **Leadership in action, not just words:** Dr. Harris didn't merely preach ideals; he actively participated in community initiatives, demonstrating commitment through hands-on involvement.
- **Advocate for the voiceless:** He consistently stood up for those without a voice, ensuring their concerns and needs were heard in civic conversations.
- **Champion of equality for all residents:** Dr. Harris promoted fairness, access, and opportunities, regardless of background, contributing to a more inclusive city.
- **Generosity and service to the community:** He gave his time, resources, and expertise to strengthen local organizations and initiatives.
- **Mobilizing and guiding collective action:** He inspired and led others, helping unite diverse communities toward shared goals for the greater good.



A statement of cost from the Superintendent of Public Works for the installation of the proposed honorary street sign.

Dr. Harris meets the qualification for this honor, as he:

- Has been deceased for at least two years
- Had strong ties to Newburgh
- Made lasting, exemplary contributions that reflect positively on the City

RESOLUTION NO.: _____ - 2026

OF

MAY 11, 2026

**A RESOLUTION NAMING THE INTERSECTION OF FIRST STREET AND
MONTGOMERY STREET IN HONOR OF DR. RALPH HARRIS**

WHEREAS, Dr. Ralph Harris was born in Shreveport, Louisiana, to the late Deacon Andrew Harris and Deaconess Mattie B. Harris, where he was nurtured in a faith-filled home under the guidance of his parents; and

WHEREAS, his natural gifts as a preacher and his charismatic, yet principled, persona earned him a broad following and a reputation for speaking truth to power with grace and in 1988, he accepted the call to lead Ebenezer Baptist Church in Newburgh, NY, embracing a ministry that extended far beyond the pulpit; and

WHEREAS, during his tenure as senior pastor, Dr. Harris actively engaged with the broader community by lending his voice to education, youth development, and interfaith and interorganizational collaboration, serving on the Newburgh City School District Advisory Council, and helping to shape youth opportunities through the Glenn E. Hines Memorial Boys/Girls Club, in addition to participating in a network of organizations that sought to uplift families and neighborhoods; and

WHEREAS, his leadership was characterized by a steady commitment to equity and opportunity by guiding, mentoring, and organizing across faith and civic lines to help bring people together to address critical local issues and his influence extended to statewide networks, as he contributed to the Empire State Missionary Baptist Convention and the National Baptist Convention USA, reinforcing the role of church leadership in public service; and

WHEREAS, Dr. Harris's legacy is preserved in the ongoing work of the programs and partnerships he helped establish and in the memories of those who witnessed his dedication to the people of Newburgh through his many contributions to the community, the City of Newburgh, and the State of New York at large, including his service as Member of Newburgh City School District Advisory Council; President of the Black Ministerial Fellowship; Member of the Glenn E. Hines Memorial Boys/Girls Club; Charter board member of "Project Life"; Member of the Empire State Missionary Baptist Convention; and Board Member of Central Hudson Baptist Association; and

WHEREAS, his life remains a testament to the power of faith-led civic engagement and fearless advocacy for the rights and dignity of all residents;

NOW, THEREFORE, BE IT RESOLVED, in recognition of the contributions of Dr. Ralph Harris to the City of Newburgh and Ebenezer Baptist Church, that the intersection of First Street and Montgomery Street be dedicated in his honor and that an unveiling of signage indicating this dedication be held, with appropriate ceremony, at a date to be coordinated by and among Ebenezer Baptist Church, the Harris family and the City of Newburgh; and that a copy of this resolution be forwarded to the family of Dr. Harris, with greatest respect, from the entire Newburgh City Council; and

BE IT FURTHER RESOLVED, that the City Manager be and he is hereby authorized to effectuate the necessary and appropriate signage in keeping herewith.

DRAFT

RESOLUTION NO.: _____ - 2026

OF

MAY 11, 2026

**A RESOLUTION NAMING THE INTERSECTION OF MONTGOMERY STREET
AND SOUTH STREET IN HONOR OF ROBERT W. MOODY**

WHEREAS, Robert W. Moody arrived in the City of Newburgh after graduating from Elizabeth City State College in North Carolina, was the first African-American teacher at the Grand Street School, and for the next 32 years was a pioneer in the field of education in the Newburgh Enlarged City School District; and

WHEREAS, Mr. Moody was the first African-American sixth grade teacher at the Montgomery Street School (now Horizons on the Hudson) where supervised the safety patrol, the Science Club, and Poetry Meets, eventually becoming Principal in 1968 and serving in that role until the mid-1980's; and

WHEREAS, from the mid-1980's until he retired in 1990, Mr. Moody was the first African-American Principal of the Vails Gate High Tech Magnet School where a plaque in the school foyer memorializes his work overseeing building renovations; and

WHEREAS, Mr. Moody's impact upon the African-American community of Newburgh through his countless contributions to the youths and families extended beyond the boundaries of the school building as an educator, mentor, role model, and sometimes a surrogate paternal figure and motivated and encouraged immeasurable lives as he shaped and guided the youths and families of this community and he unselfishly dedicated his time to encourage physical and emotional development through sports and promoted positive school/family/community relationships, which made him well respected; and

WHEREAS, he believed that every child deserved to receive a good education and sustenance and worked tirelessly with his staff and members of the community to ensure that every resource available was afforded to those who required support; and he did everything within his ability to achieve that goal; and

WHEREAS, Mr. Moody was the recipient of countless accolades, awards, and honors, including an appointment by Governor Nelson Rockefeller to the Board of Visitors of Highland State Training School for Boys in 1968 where his work continued after his retirement, and served on the board of many local organizations that worked for the improvement of Newburgh's youth; and

WHEREAS, Mr. Moody devoted his life and time to faith, family/friends, community and sports and was an active member of the community who played basketball for the CWA

(Community Workers' Association), under the supervision of another Newburgh "Hidden Figure", Mr. Glenn Hines, baseball and football with various leagues in the City of Newburgh and Town of New Windsor, NAACP, Masonic Lodge, and Vails Gate Fire Company;

NOW, THEREFORE, BE IT RESOLVED, in recognition of the contributions of Robert W. Moody to the City of Newburgh and the Newburgh Enlarged City School District, that the intersection of Montgomery Street and South Street be dedicated in his honor and that an unveiling of signage indicating this dedication be held, with appropriate ceremony, at a date to be coordinated by the Newburgh Reunion Committee, the Moody family, and the City of Newburgh; and that a copy of this resolution be forwarded to the family of Mr. Moody, with greatest respect, from the entire Newburgh City Council; and

BE IT FURTHER RESOLVED, that the City Manager be and he is hereby authorized to effectuate the necessary and appropriate signage in keeping herewith.

DRAFT

March 8, 2026

To Mayor Harvey and the members of the City of Newburgh Council and Legislative body,

The members of the Newburgh Reunion Committee, and the family of Robert W. Moody, a former educator and administrator with the Newburgh Enlarged City School District, submit to you this written request to rename and/or annex the corner of Montgomery and South Streets in honor of Mr. Robert W. Moody.

Mr. Moody served as teacher in the early 1960s, and was later named principal in 1968, of Montgomery Street School, (now Horizons on the Hudson), until his relocation to Vails Gate School in the mid 1980s from where he retired in 1990.

His impact upon the community, particularly the African-American community of Newburgh, was substantial and in our humble opinion, deserves recognition by the city at large.

For 32 years, from 1958 to 1990, Mr. Moody was a pioneer in the field of education in the Newburgh Enlarged City School District. His countless contributions to the youths and families of this community extended beyond the boundaries of the school building. He was involved in the lives (and hearts) of the community at large. He was an educator, mentor, role model, and sometimes a surrogate paternal figure. He motivated and encouraged immeasurable lives as he shaped and guided the youths and families of this community. He unselfishly dedicated his time to encourage physical and emotional development through sports and promoted positive school/family/community relationships, which made him well respected.

He believed that every child deserved to receive a good education and sustenance. He worked tirelessly with his staff and members of the community to ensure that every resource available was afforded to those who required support; and he did everything within his ability to achieve that goal.

When Mr. Moody came to Newburgh in 1958, having graduated from Elizabeth City State College, in North Carolina, he was the first African-American teacher at Grand Street School. He later moved to Montgomery Street School where he was again, the first African-American sixth grade teacher and supervised the safety

patrol, Science Club, and Poetry Meets. He was named principal of Montgomery Street, in 1968 and served there until he became in the mid 1980s, once again, the first African-American principal of Vails Gate High Tech Magnet School, from where he retired in 1990. Among his many accomplishments while building leader at Vails Gate included: overseeing building renovations, for which there is a plaque in the school foyer memorializing this work.

Mr. Moody was the recipient of countless accolades, awards, and honors. In 1968, He was appointed by Governor Nelson Rockefeller, to the Board of Visitors of Highland State Training School for Boys. He also served on the board of many local organizations that worked for the improvement of Newburgh's youth. Upon his retirement, he continued working with the Highland School for Boys until his health concerns prevented his involvement.

Additionally, Mr. Moody was an active member of the community. He played basketball for the CWA (Community Workers' Association), under the supervision of another Newburgh "Hidden Figure", Mr. Glenn Hines, baseball and football with various leagues in the City of Newburgh and Town of New Windsor, NAACP, Masonic Lodge, and Vails Gate Fire Company.

Mr. Moody devoted his life and time to faith, family/friends, community and sports. His accomplishments were rewarded with countless accolades, awards, and honors. His life of service ended on July 10, 2019, when he passed away.

Respectfully Submitted by,

Newburgh Reunion Committee - Mr. Harold Shirley

The family of Robert W. Moody - Ms. Karen Moody, Mrs. Kelly Moody-Williams

RESOLUTION NO.: _____ - 2026

OF

_____, 2026

**A RESOLUTION BESTOWING A KEY TO THE CITY OF NEWBURGH
IN HONOR OF HAROLD SHIRLEY**

WHEREAS, Harold Shirley, affectionately known as "Hardy," attended schools within the Newburgh Enlarged City School District and proudly served his country in the United States Army, and then returning to his hometown of Newburgh to build a fulfilling career, working for the NECSD and the Montrose Veterans Administration Hospital; and

WHEREAS, although Harold, his wife, Paula, and family relocated to Raleigh, North Carolina in 1999, he never turned his back on Newburgh and instead stayed actively involved, supporting the City by any means necessary rooted in a desire to see Newburgh continue to thrive, grow, and bring about positive change, just as it had during his youth; and

WHEREAS, as a reminder and testament to his outlook on community unity and service Hardy, in 2002, founded and served as the first president of the original Newburgh, NY Reunion with his wife and mother to create a meaningful way to bring family and friends together for three unforgettable days, in various states, which features a warm meet-and-greet, a formal banquet with an awards ceremony, along with a heartfelt worship service, fostering connection, celebration, and community; and

WHEREAS, confirming Hardy's firm belief that education is the key to unlocking potential and creating opportunities for young people, a standout element of the reunion is its dedication to supporting education by awarding scholarships to high school students from Newburgh free Academy who achieve a 3.0 GPA or higher; and

WHEREAS, on May 1, 2009, Hardy was honored at the Change Your Community, Change Your World event hosted by the Glenn E. Hines Boys and Girls Club and received the prestigious Alumni Hall of Fame Inductee Certificate of Recognition from Mayor Nicholas Valentine, a Certificate of Merit from Senator William J. Larkin Jr., and a Certificate of Special Congressional Recognition from the Members of Congress which acknowledged his outstanding and invaluable service to the community; and

WHEREAS, Hardy was instrumental in assisting the 2009 NFA New York State Class AA Championship basketball team purchase a commemorative ring for their beloved mascot and team manager, Danny "Butterfly" Washington, who had been an integral part of their journey; and

WHEREAS, in 2016, Hardy was honored by the NAACP for his exceptional service to the community, and in 2021, Hardy played an instrumental role in honoring his late friend, Terry "LD" Williams, by helping to rename the street where he grew up in his honor, as well as playing a significant role in the renaming of Gidney Avenue Park to Clyde H. Sims Park in 2022; and

WHEREAS, Hardy is Newburgh, a living symbol of its resilience, compassion, and unshakable sense of community and his tireless efforts, unhindered by his now personal physical impairment, continue to inspire those around him, reminding us that the spirit of Newburgh lives on in the love, pride, and unity of its people and his work stands as a shining testament to the power of preserving the past while building a brighter and more hopeful future for generations to come;

NOW, THEREFORE, BE IT RESOLVED, in recognition of his life's work, dedication, and service to the Newburgh community, the City Council of the City of Newburgh hereby bestows upon Harold Shirley the ceremonial "Key to the City," representing this Council's respect, admiration and appreciation for his myriad of contributions to the City of Newburgh.

DRAFT

Dear Mr. Todd Venning, Mayor Torrance Harvey and Council Members:

We, the family of Mr. Harold Shirley (aka Hardy), and the friends of the Newburgh Reunion Committee are submitting this request to have Harold be a recipient of the Key to the City for all the humanitarian work he has accomplished assisting the youth and acknowledging the accomplishments of many adults in the City of Newburgh.

Harold Shirley, affectionately known as "Hardy," attended schools within the Newburgh Enlarged City School District. After High School, Hardy proudly served his country by joining the United States Army. After completing his tour of duty, he returned to his hometown of Newburgh, where he went on to build a fulfilling career, working for the NECSD and the Montrose Veterans Administration Hospital.

In 1999, Harold and his beloved wife, Paula, made the decision to relocate to Raleigh, North Carolina, with their three sons and in 2006, they were overjoyed to welcome their daughter, Cammora, into their family

Hardy never turned his back on Newburgh—the great city where he came from. Just as he remained committed to Newburgh, the city never turned its back on him or his family. Over the past 25 years, Hardy stayed actively involved, supporting the city by any means necessary. His dedication was rooted in a desire to see Newburgh continue to thrive, grow, and bring about positive change, just as it had during his youth.

Newburgh was once celebrated as an "All-American City" by Look magazine in 1952 for its industry, prosperity, cleanliness, and safety—qualities made possible by the hard work and sacrifices of our ancestors and forefathers. The city was built on the backs of our families, and Hardy believes in honoring that legacy. He reminded others that no single person can create change alone; it takes a community united in purpose. Whether we still live in Newburgh or have moved away, it remains our great city. Hardy encouraged everyone not to turn their backs on Newburgh and to take part in its revival.

"I am a proud product of the people who paved the way for me," Hardy often said. "The lights of Newburgh still shine bright, and our city has great people leading us forward, back to the greatness we once knew."

As the founder and president of the original Newburgh, NY Reunion, Harold Shirley, alongside his wife Paula and his mother Elsie, began this journey of reconnection and celebration in 2002. He believed he was chosen by God to bring people together, and the reunion became a testament to the enduring spirit of Newburgh.

The Newburgh, NY Reunion was created as a meaningful way to bring family and friends together for three unforgettable days, hosted in various states. The event features a warm meet-and-greet, a formal banquet with an awards ceremony, along with a heartfelt worship service, fostering connection, celebration, and community. A standout element of the reunion is its dedication to supporting education by awarding scholarships to high school students from Newburgh free Academy who achieve a 3.0 GPA or higher. Hardy firmly believes that education is the key to unlocking potential and creating opportunities

On May 1, 2009, Hardy was honored at the Change Your Community, Change Your World event hosted by the Glenn E. Hines Boys and Girls Club. During this ceremony, Hardy received the prestigious Alumni Hall of Fame Inductee Certificate of Recognition from Mayor Nicholas Valentine, a Certificate of Merit from Senator William J. Larkin Jr., and a Certificate of Special Congressional Recognition from the Members of Congress. These honors acknowledged his outstanding and invaluable service to the community.

On March 24, 2009, the NFA basketball team celebrated a historic victory, winning the New York State Class AA Championship. Following their triumph, the team purchased championship rings to commemorate their achievement. However, due to budget constraints, they were unable to provide a ring for their beloved mascot and team manager, Danny “Butterfly” Washington, who had been an integral part of their journey.

Recognizing this, some of the basketball players reached out to Hardy for help. Without hesitation, Hardy drove to Newburgh and met with the basketball team’s faculty to gather the necessary details about where and how to purchase a ring for Danny. After obtaining Danny’s ring size and the required information, Hardy made the arrangements and personally purchased the championship ring that Danny so deeply deserved.

Later in 2009, the ring was presented to Danny. His joy was undeniable, and his family was deeply moved—not only by the ring itself but by Hardy’s thoughtful initiative to ensure Danny’s contributions were honored. This heartfelt act was a testament to Hardy’s character, generosity, and belief that everyone who plays a role in a team’s success deserves to be celebrated.

In 2016, Hardy was honored by the NAACP for his exceptional service to the community, a recognition many felt was well-deserved after years of hard work which produced impact within the community.

Hardy had a deep passion for ensuring people were recognized for their hard work, particularly those who made a significant impact in Newburgh. In 2021, Hardy played an instrumental role in honoring his late friend, Terry “LD” Williams, by helping to have the street where Terry grew up named after him. This heartfelt gesture was deeply meaningful to Hardy, as Terry was the first African American from Newburgh to make it to the NBA.

One of Hardy’s recent accomplishments was his instrumental role in the renaming of Gidney Avenue Park to Clyde H. Sims Park in 2022. This meaningful endeavor exemplified Hardy’s unwavering dedication to honoring those who have left a lasting legacy in the community.

Hardy is Newburgh—a living symbol of its resilience, compassion, and unshakable sense of community. His tireless efforts, unhindered by his now personal physical impairment, continue to inspire those around him, reminding us that the spirit of Newburgh lives on in the love, pride, and unity of its people. Hardy’s work stands as a shining testament to the power of preserving the past while building a brighter and more hopeful future for generations to come.

May God bless you all, and may God continue to bless the great city of Newburgh.

While we understand that the Key to the City is a symbolic award, it is a way for Newburgh to express its appreciation and honor Harold Shirley, who has made significant contributions to the lives of so many. We appreciate your consideration in this matter and await a response.

Sincerely,

Mrs. Paula Shirley

The Family of Harold Shirley, Sr.

Ms. Alice Frazier

Newburgh Reunion Committee

Bishop Jeffrey C. Woody
The Cathedral at The House
[131 Broadway](#)
[Newburgh, NY 12550](#)
845.565.5910

Section 14-2(A) & (B) provide for a Commission of 9 members for 3-year terms as follows:

- 2/3 of the members shall be residents of the City of Newburgh
- Non-residents shall have a demonstrated investment in the City of Newburgh.

Section 14-2(E) provides for a maximum of 5 advisory members

- No voting rights
- Non-residents are eligible

Current Members:

- Erica Forneret - term expires 7/9/26
- Penelope Taylor - term expires 7/9/26
- Debra Lamb - term expires 6/9/27
- Gary Castelli - term expires 6/9/27
- Patricia C. Phillips - term expires 7/9/28
- Paul Ellis - term expires 7/9/28
- Madison Hermida - term expires 7/9/28
- Duane Rutter - term expires 7/9/28

One full membership vacancy due to resignation - complete term ending on November 11, 2028.

Five advisory member vacancies

Applicants seeking initial appointment for vacancy:

- Taussen Brewer
- Megan Galante
- LotuZ

NEWBURGH GREEN LIGHT PROCESS

Framework to Fast-Track Resident Concerns

What is the Green Light Process?

The Newburgh Green Light Process (NGLP) is a process utilized by the City Council to streamline council responsiveness to residents. This pathway will allow qualified items to be resolved quickly without sacrificing transparency or the public's trust. When a qualified item meets the Green Light criteria, it's placed on an expedited track which should be resolved within at least two council sessions.

Note: Charter section C4.01.A: Council proceedings are governed by rules the Council adopts. GLP will be adopted by the Council as a Council Rules amendment (New Rule). Which will be legally binding. This effort will be grounded in the authority given to Council in the Charter and it aligns with NYCOM best practice for council-manager styles of government.

Purpose

We encourage residents to come out to voice their concerns at city council meetings and many do just that. It can often feel like residents are repeating themselves or because their concerns are not being addressed in an appropriate timeframe. Sometimes matters that are brought forward are complex and require extensive research, legal analysis, a change in the budget or must go through a required process. What happens when items are straightforward and time-sensitive? They too can get stuck in the ether of bureaucracy or wait in the standard queue, that really doesn't exist. The Green Light process will separate those items so residents can see faster results from the city and its elected officials.

Eligibility Criteria

In order to be considered for the GLP, the item must meet All of the following criteria:

1. Must be routine or administrative in nature and not require significant change to policy or create a new precedence.
2. There is no public opposition or anticipated objection. Staff can confirm there are no lingering community concerns.

3. Council recommended the matter for the Green Light queue. If a staff person wants to recommend an item for GLP it must have council sponsorship. i.e. (Department heads may submit an item for the queue, but it must have council sponsorship.)
4. Straightforward and doesn't require any extensive legal review to be cleared for action.

Items that are NOT Eligible for GLP

- Anything that may have a significant negative impact on community.
- Items that involve funding over the \$20,000 threshold.
- Matters that require a public hearing.
- Issues that have an unresolved question or are objected to by a councilmember.

How does GLP work?

| Step | Action | Details |
|------|-------------------------|---|
| 1 | Council recommends item | Item then goes directly to the City Clerk for the record. |
| 2 | Qualifying Item Notice | Put on the agenda under GLP section |
| 3 | Council Action | GLP items are approved by a simple majority vote at a regular session. Any item can be pulled at any time by a councilmember. |
| 4 | Item Addressed | Item resolved and recorded. |

Safeguards

The Green Light Process is designed to fast-track action for residents without circumventing accountability. Therefore, some safeguards will be in place:

- Any council member can pull an item at any time, no reason required.
- A GL item is approved by a single motion at the regular session. Any councilmember may pull any item before or during the motion.
- There should be a quarterly review of all items that were fast-tracked and reported to the public by clerk or council.